

LIQUID CRYSTAL DISPLAY MODULE

Product Specification

PRODUCT NUMBER	84-0204-000T
-----------------------	---------------------

INTERNAL APPROVALS		
Product Manager	Engineering	Document Control
Gregory Hayes		
Date:12/7/2014	Date:	Date:

TABLE OF CONTENTS

1	GENERAL SPECIFICATIONS	4
2	FEATURES	4
3	MECHANICAL DRAWING	5
4	ABSOLUTE MAXIMUM RATINGS	7
5	ELECTRICAL CHARACTERISTICS	ERROR! BOOKMARK NOT DEFINED.
6	BACKLIGHT CHARACTERISTICS	ERROR! BOOKMARK NOT DEFINED.
7	BLOCK DIAGRAM	7
8	ELECTRO-OPTICAL CHARACTERISTICS	8
9	CONNECTORS AND JUMPER SETTINGS	12
9.1	CONNECTORS	12
9.1.1	<i>Power Supply Connector (J14)</i>	<i>12</i>
9.1.2	<i>LCD Connector (J15)</i>	<i>12</i>
9.1.3	<i>USB Device Interface (J11)</i>	<i>13</i>
9.1.4	<i>PIC Controller Programming (TBD)</i>	<i>13</i>
9.1.5	<i>EEPROM Programming (TBD)</i>	<i>13</i>
9.1.6	<i>External PWM and Enable control (TBD)</i>	<i>13</i>
9.1.7	<i>HDMI Connector (TBD)</i>	<i>Error! Bookmark not defined.</i>
9.1.8	<i>External I2C Touch Connector (TBD)</i>	<i>14</i>
9.1.9	<i>Touch Pad Connector(TBD)</i>	<i>14</i>
10	JUMPERS CONFIGURATION	14
10.1.1	<i>Touch Interface Voltage Selection (TBD)</i>	<i>14</i>
11	BASIC DISPLAY COLOR AND GRAY SCALE	14
12	RELIABILITY TEST	15
13	INCOMING INSPECTION STANDARDS	16
13.1	THE ENVIRONMENTAL CONDITION FOR INSPECTION	16
13.2	CLASSIFICATION OF DEFECTS AND AQL	17
13.3	INSPECTION PARAMETERS	17
14	HANDLING PRECAUTIONS	21

REVISION RECORD

Rev.	Date	Page	Par.	Comment	ECN no.
A	3/27/14	--	--	New DCA Spec.	E4943

Preliminary

1 GENERAL SPECIFICATIONS

ITEM	DESCRIPTION	UNIT
Module Outline Dimensions	266.96 (H) x 185.6(V) x 11.6 (T) (Not including cable)	mm
Active Display Area	217.96(H) x 136.6 (V)	mm
Pixel Configuration Format / Resolution	1280 (H) x 800 (V)	pixels
LCD Type	Transmissive / Normally Black	--
Backlight Type	LED	--
Weight	TBD	gram
Interface	HDMI	--
Luminance, White	280 cd/m ²	
Dot Pitch	0.050mm x 0.150mm	mm
Color Depth	Hi FRC, 16.7M Colors	--
RoHS Compliant	Yes	--
Surface Treatment	Clear coating, 7H	--

2 FEATURES

- The display module is an 10.1” diagonal WXGA supported TFT-LCD and can display 16.7M colors (Hi FRC).
- Glass-film-film PCT, with I2C interfaces.
- USB, SPI or Serial interface
- Solidworks model available with Densitron NDA on file.

3 MECHANICAL DRAWING

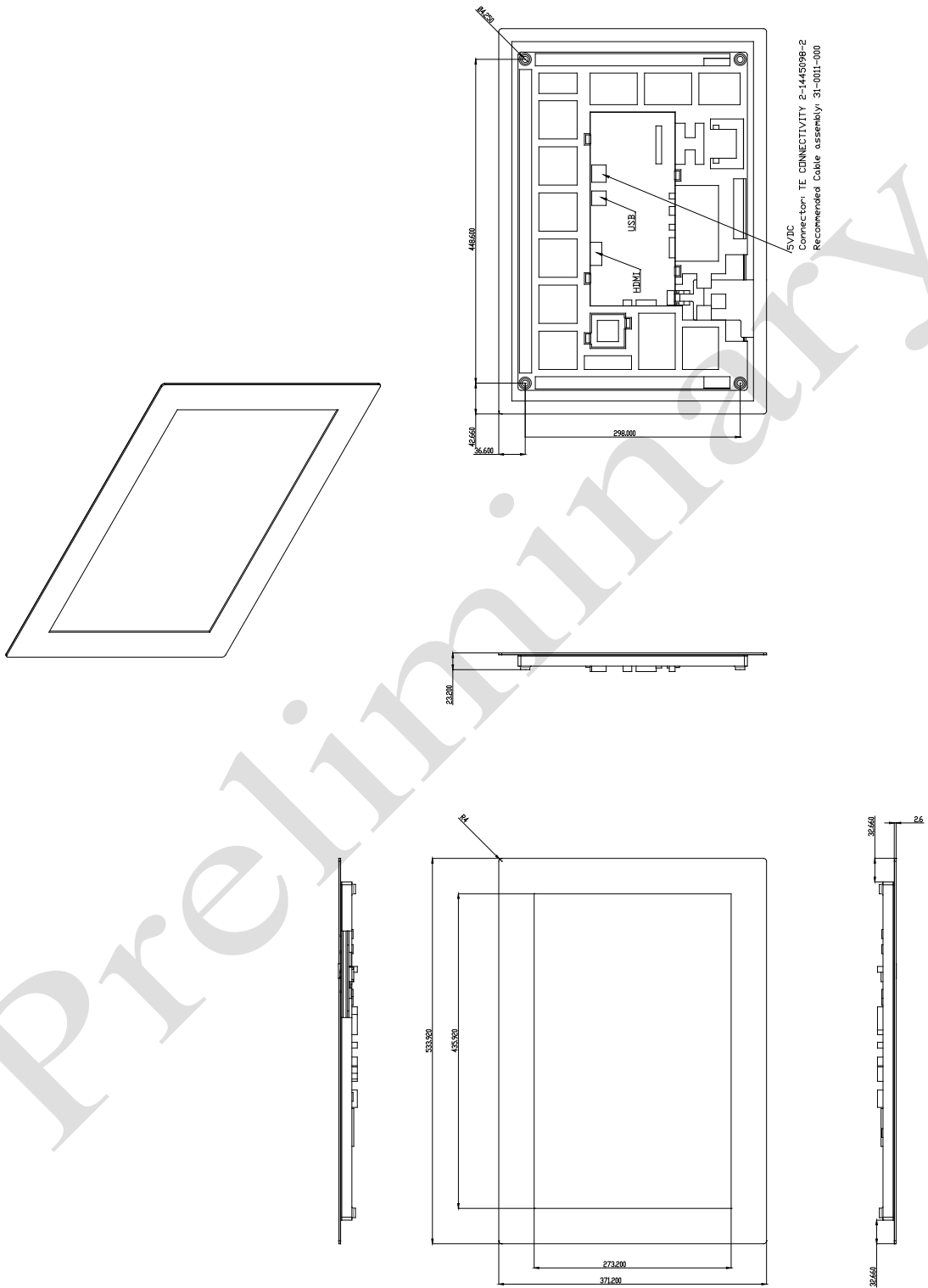

Product No.	84-0204-000T	REV.A
-------------	--------------	-------

Page	5 / 22
------	--------

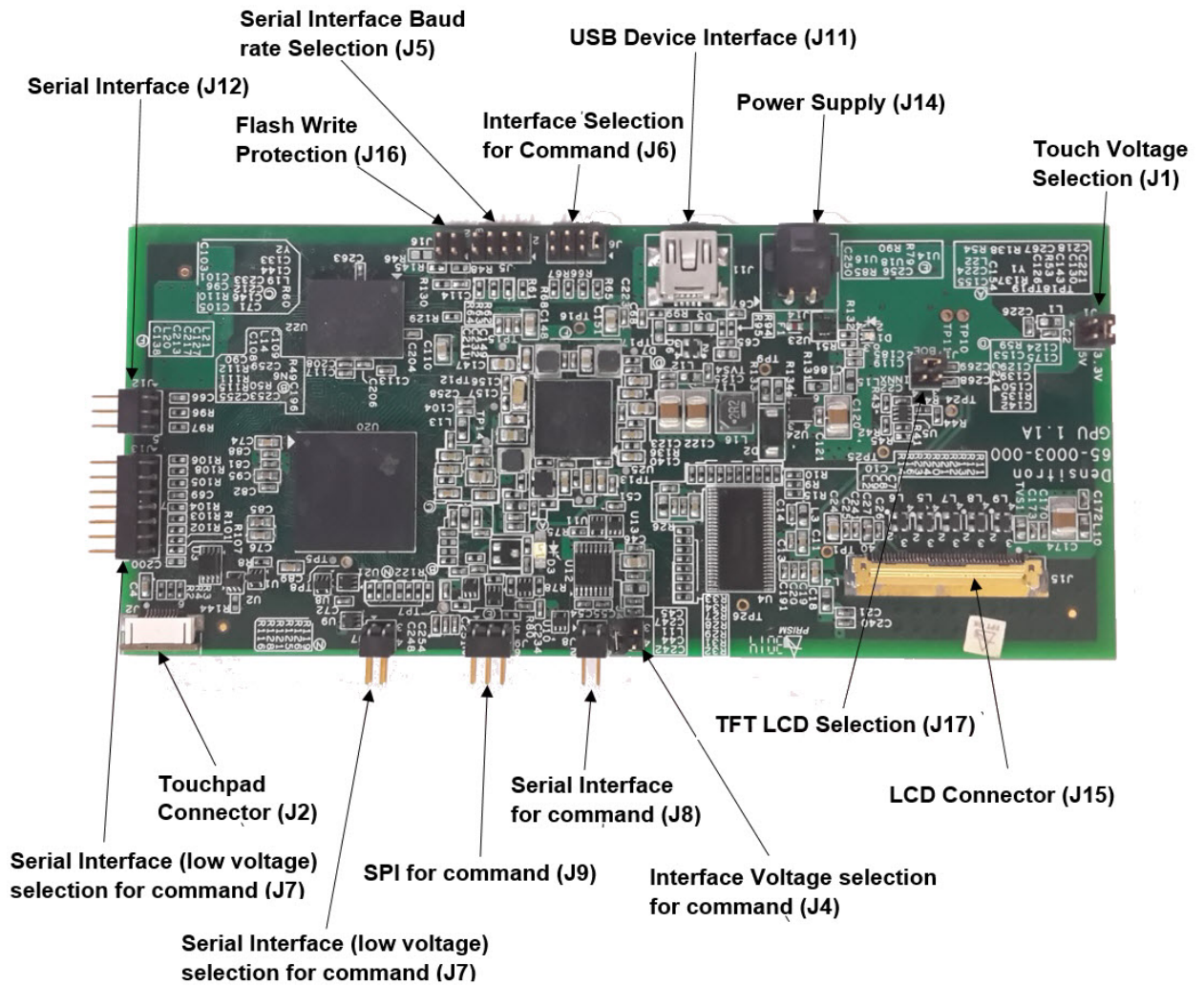

4 ABSOLUTE MAXIMUM RATINGS

The followings are maximum values which, if exceed, may cause faulty operation or damage to the unit. The operational and non-operational maximum voltage and current values are listed in Table 2.

< Table 2. LCD Module Electrical Specifications > [Ta =25±2 °C]

Parameter	Symbol	Min.	Max.	Unit	Remarks
Power Supply Voltage (LCD Module)	V _{DD}	4.8	5.2	V	
Operating Temperature	T _{OP}	-10	+50	°C	1)
Storage Temperature	T _{ST}	-20	+60	°C	

5 BLOCK DIAGRAM

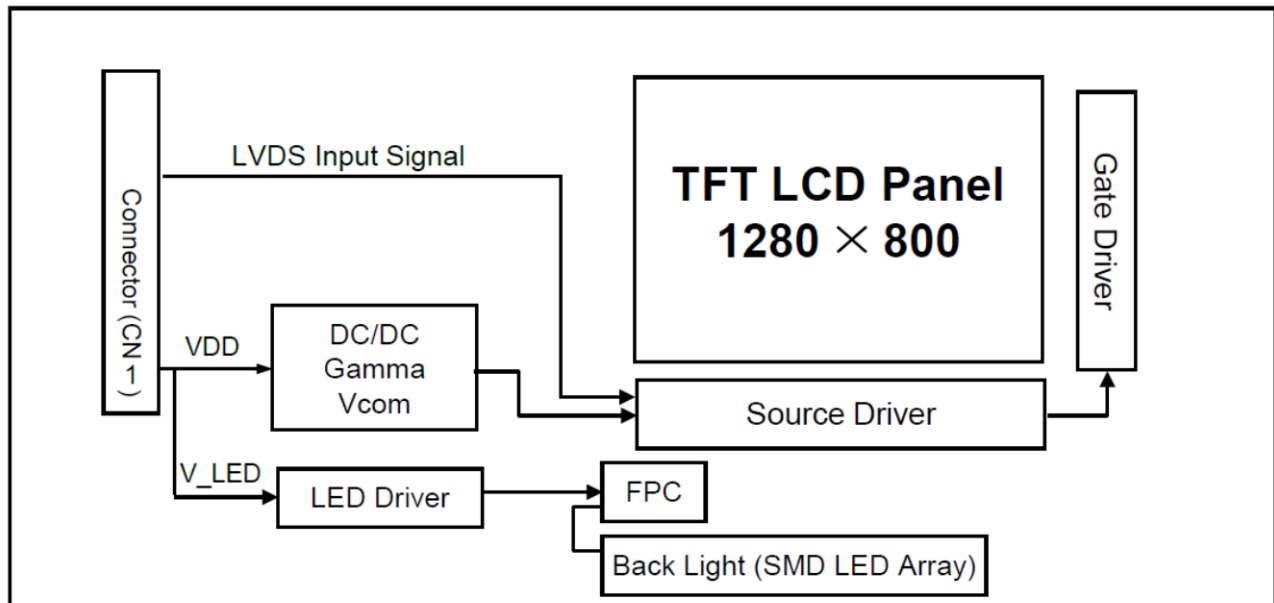

6 ELECTRO-OPTICAL CHARACTERISTICS

Preliminary

Product No.	84-0204-000T	REV.A
-------------	--------------	-------

Page	8 / 22
------	--------

Parameter		Symbol	Condition	Min.	Typ.	Max.	Unit	Remark
Viewing Angle range	Horizontal	Θ_3	CR > 10	70	80	-	Deg.	Note 1
		Θ_9		70	80	-	Deg.	
	Vertical	Θ_{12}		70	80	-	Deg.	
		Θ_6		70	80	-	Deg.	
Color Gamut			-	50	-	%		
Luminance Contrast ratio		CR	$\Theta = 0^\circ$	600	-	-		Note 2
Luminance of White	5 Points	Y_w	$\Theta = 0^\circ$	280	330	-	cd/m ²	Note 3
White Luminance uniformity	5 Points	$\Delta Y5$		-	80	-		Note 4
White Chromaticity		W_x	$\Theta = 0^\circ$	Typ. -0.03	0.313	Typ. +0.03		Note 5
		W_y			0.329			
Reproduction of color	Red	R_x	$\Theta = 0^\circ$	Typ. -0.03	0.600	Typ. +0.03		
		R_y			0.340			
	Green	G_x			0.315			
		G_y			0.565			
	Blue	B_x			0.150			
		B_y			0.125			
Response Time (Rising + Falling)		T_{RT}	Ta= 25° C $\Theta = 0^\circ$	-	25	-	ms	Note 6
Cross Talk		CT	$\Theta = 0^\circ$	-	-	2.0	%	Note 7

Optical characteristics are determined after the unit has been 'ON' and stable for approximately 5 minutes in a dark environment at 25°C. The values specified are at an approximate distance 50cm from the LCD surface at a viewing angle of Φ and Θ equal to 0°.

FIG. 1 presents additional information concerning the measurement equipment and method.

FIG. 1 Optical Characteristic Measurement Equipment and Method

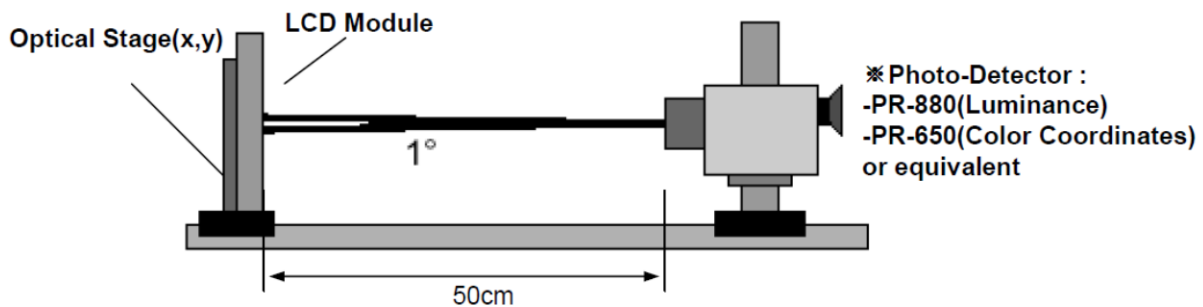

[Note 4-1] Contrast Ratio(CR) is defined mathematically as

$$\text{Contrast Ratio} = \frac{\text{Surface Luminance with all white pixels}}{\text{Surface Luminance with all black pixels}}$$

[Note 4-2] Surface luminance is measured at the center point(L₁) of the LCD with all pixels displaying white at the distance of 50cm by PR-880. Color Coordinates are measured at the center point(L₁) of the LCD with all pixels displaying red, green, blue and white at the distance of 50cm by PR-650. For more information, refer to the FIG 1 and FIG 2.

[Note 4-3] Luminance uniformity is measured for 9 point For more information see FIG 2.

$$\delta_{\text{WHITE}} = \text{Maximum}(L_1, L_2, \dots, L_9) \div \text{Minimum}(L_1, L_2, \dots, L_9)$$

[Note 4-4] Response time is the time required for the display to transition from white to black (Rise Time, Tr_R) and from black to white(Decay Time, Tr_D). For additional information see FIG 3.

[Note 4-5] Viewing angle is the angle at which the contrast ratio is greater than 10. The angles are determined for the horizontal or x axis and the vertical or y axis with respect to the z axis which is normal to the LCD surface. For more information see FIG 4.

FIG. 2 Luminance

<measuring point for surface luminance & measuring point for luminance variation>

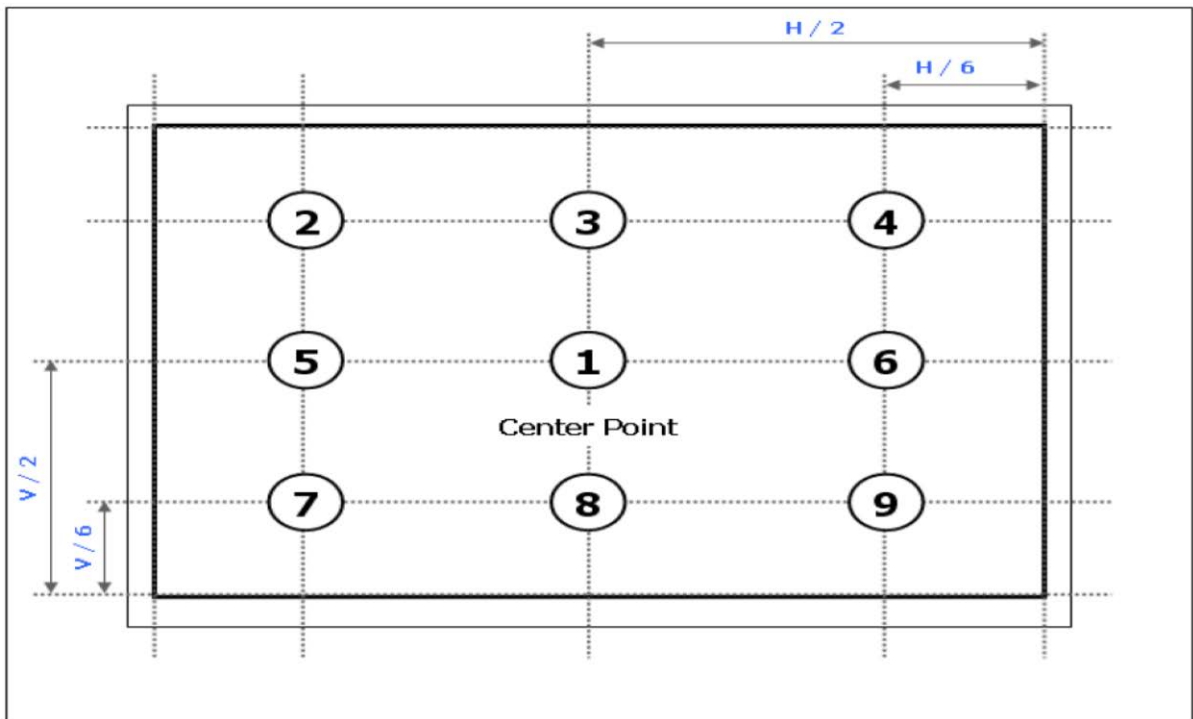

FIG. 3 Response Time

The response time is defined as the following figure and shall be measured by switching the input signal for “black” and “white”.

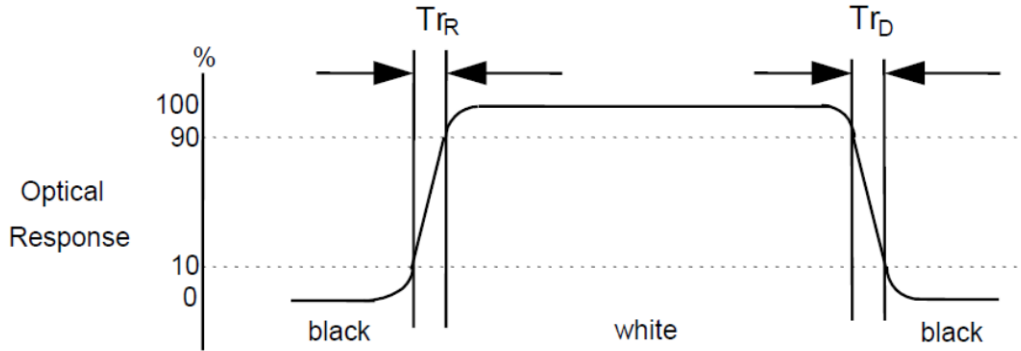
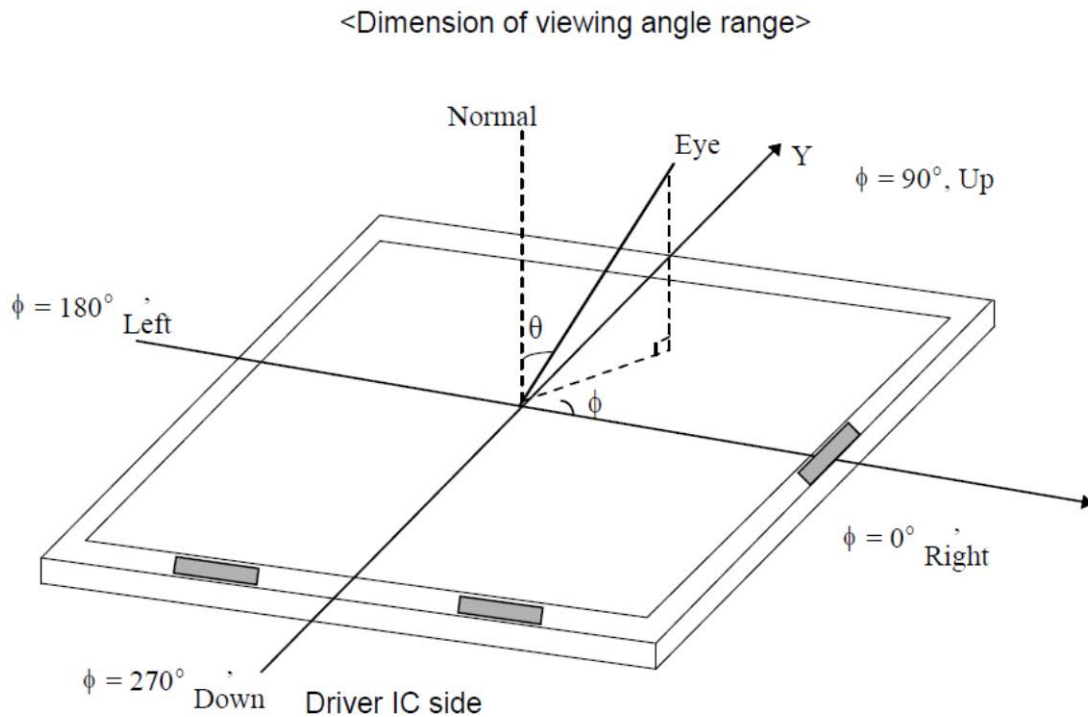

FIG. 4 Viewing angle



7 CONNECTORS AND JUMPER SETTINGS

7.1 Connectors

7.1.1 Power Supply Connector (J14)

Pin	Name	Description
1	5V	5V 2A DC
2	GND	Ground

7.1.2 LCD Connector (J15)

Pin	Name	Description
1	GND	Ground
2	NC	No Connection
3-4	VCC	3.3V 2A DC
5-6	VCC	3.3V 2A DC
7	GND	Ground
8	Y0M	Negative LVDS Differential 0th Data
9	Y0P	Positive LVDS Differential 0th Data
10	GND	Ground
11	Y1M	Negative LVDS Differential 1st Data
12	Y1P	Positive LVDS Differential 1st Data
13	GND	Ground
14	Y2M	Negative LVDS Differential 2nd Data
15	Y2P	Positive LVDS Differential 2nd Data
16	GND	Ground
17	CLKM	Negative LVDS Differential CLK Data
18	CLKP	Positive LVDS Differential CLK Data
19	GND	Ground
20	Y3M	Negative LVDS Differential 3rd Data
21	Y3P	Positive LVDS Differential 3rd Data
22	GND	Ground
23	NC	No Connection
24-25-26	BL_LED+	Back-Light LED Positive Terminal END
27	NC	No Connection
28-29-30	BL_LED-	Back-Light LED Negative Terminal END

7.1.3 USB Device Interface (J11)

The mini AB connector used to connect the board to the Host as a USB device. It emulates the USB to virtual serial.

Pin	Name	Description
1	5V	5V power
2	D-	Data differential pair minus
3	D+	Data differential pair plus
4	ID	On the Go identification
5	GND	Ground

7.1.4 Serial Interface (Low Voltage) for commands (J7)

The Serial Interface UART for commands. The voltage level of the signal can be configured using J4.

Pin	Name	Description
1	TX	Serial Data Output Signal
2	RX	Serial Data Output Signal
3	RESET	Active low to reset the RipDraw board
4	GND	Ground

7.1.5 Serial Interface for commands (J8)

The Serial Interface UART for commands. The voltage level is RS-232 standard.

Pin	Name	Description
1	TX	Serial Data Output Signal
2	RX	Serial Data Output Signal
3	RESET	Active low to reset the RipDraw board
4	GND	Ground

7.1.6 SPI (Serial Peripheral Interface) for commands (J9)

Pin	Name	Description
1	CLK	Serial clock
2	MISO	Master Input, slave output
3	SIMO	Slave input, master output
4	CS	Chip select
5	Reset	Active low to reset the RipDraw board
6	GND	Ground

7.1.7 Touch Pad Connector (J2)

Pin	Name	Description
1	VCC	5V/3.3V 2A DC
2	NC	No Connection
3	NC	No Connection
4	GND	Ground
5	TS_INT	GPIO Interrupt Signal
6	TS_RESET	GPIO Reset Signal
7	TS_SDA	I2C Data Signal
8	TS_SCL	I2C Clock Signal
9	GND	Ground

7.1.8 Serial Interface for Development ONLY (J12)

7.1.9 JTAG Interface for Development ONLY (J13)

7.2 Jumpers Configuration

7.2.1 Touch Interface Voltage Selection (J1)

This jumper used to set the Touch Panel operating voltage selection.

Pin	Description
1-2	USB 5V, for USB touch interface voltage
3-4	I2C 3.3V, for I2C touch interface voltage

7.2.2 Interface Voltage Selection (J4)

This jumper used to set the Interface I/O voltage selection for

1. Serial Interface (Low Voltage) for J7
2. SPI for J9

Pin	Description
1-2	Close for 3.3V I/O
3-4	Close for 5V I/O

7.2.3 Interface Selection for commands (J6)

The jumper used to set the command interface.

Pin	Description
1-2	Serial Interface (Low Voltage) for commands (J7)
3-4	Serial Interface (RS232) for commands (J8)
5-6	SPI (Serial Interface) for commands (J9)

Product No.	84-0204-000T	REV.A
-------------	--------------	-------

Page	14 / 22
------	---------

7-8	Unused
NONEA	No jumpers closed then USB Device Interface (J11)

7.2.4 Serial Interface Baud Rate Selection

The jumper sets the baud rate for Serial Interface (Low) (J7) or Serial Interface RS232 (J8)

7.2.5 Selection for TFT Vendor (J17)

Pin	Description
1-2	Close for BOE
3-4	Close for INNOLUX

7.2.6 Flash Write Protection (J16)

This jumper is used to Enable/Disable flash write protection.

Pin	Description
1-2 or 3-4	Close to Disable Flash Write (read/write mode “write mode disabled”)

8 RELIABILITY TEST

No.	Test Item	Test Condition
1	High Temperature Storage	70 ± 2 °C / 240 hours
2	Low Temperature Storage	-30 ± 2 °C / 240 hours
3	High Temperature Operation	60 ± 2 °C / 240 hours
4	Low Temperature Operation	-10 ± 2 °C / 240 hours
5	Temperature Cycle	-30 ± 2 °C ~ 70 °C (0.5hr.) X 50 Cycles
6	Proof against Dampness	50 ± 5 °C X 90% RH / 120 hours; Pure Water Used (Resistance > 10 MΩ)
7	Vibration Test	Frequency: 10 Hz ~ 55 Hz ~ 10 Hz Amplitude: 1.5 mm X,Y & Z directions for a total of 3 hours
8	Dropping Test	Dropped to the ground from 1 m height, one time and test ed on all sides of the carton when packed.
9	ESD Test	-Panel Surface/Top Case : 150pF, 150Ω (Air: ±15kV, Contact: ±8kV) -FPC input terminal: 100pF ±200V 0Ω

<p>Inspection after Test</p>	<p>The sample is tested for the following defects after 2 ~ 4 hours of storage at room temperature:</p> <ol style="list-style-type: none"> 1. Air bubbles in the LCD 2. Leaking Seal 3. No Display 4. Missing Segments 5. Glass Cracks 6. Idd current is higher than twice the initial value
<p>Remarks:</p> <ol style="list-style-type: none"> 1. The test samples are applicable to only one test group. 2. Sample size for each test group is 5 ~ 10 pieces. 3. In case of a malfunction caused by ESD test, if it recovers to the normal state after resetting, it would be judged as a good part. 4. EL backlights can produce black spots/blemishes in humidity and temperature test due to natural chemical reactions and fluorescence. This is checked for. 5. Please use automatic switch menu (or roll menu) in test mode. 	

9 INCOMING INSPECTION STANDARDS

9.1 THE ENVIRONMENTAL CONDITION FOR INSPECTION

The environmental condition and visual inspection shall be conducted as below.

- (1) Ambient temperature: 25 ± 5 °C
- (2) Humidity: $60 \pm 5\%$ RH
- (3) Viewing distance: 35 ~ 40 cm approx.
- (4) Viewing angle: Normal to the LCD panel as shown below
- (5) Ambient Illumination: 300 ~ 500 Lux. for external appearance inspection.

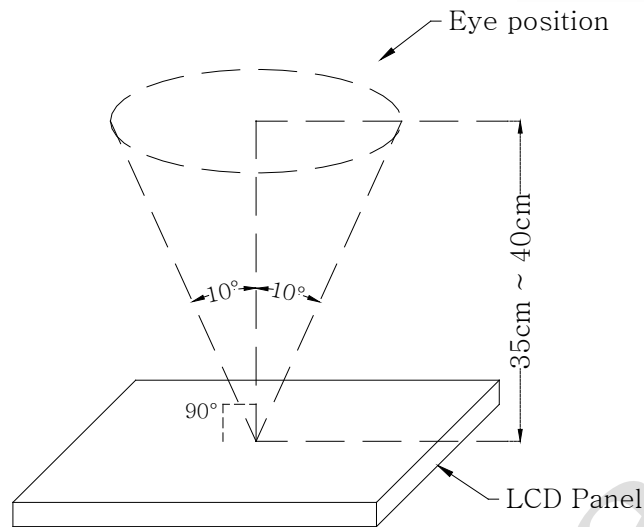

9.2 CLASSIFICATION OF DEFECTS AND AQL

Class of defects	AQL	Definition
Major	1.0%	It is a defect that is likely to result in failure or to reduce materially the usability of the intended function.
Minor	1.5%	It is a defect that will not result in a functioning problem with deviation classified.

Note: Sampling plan according to GB / T2828.1-2003 / ISO 2859-1:1999 and ANSI/ASQC Z1.4-1993, Normal level 2.

9.3 INSPECTION PARAMETERS

Item		Specification / Description		Note
Display	Function	No display		-
		Malfunction		-
Operating	Contrast ratio	Out of spec.		-
	Line defect	No obvious Vertical and Horizontal line defects for the bright, dark and colored.		-
	Point defect (red,	Item	Acceptable number	1, 4,

Product No.	84-0204-000T	REV.A
-------------	--------------	-------

Page	17 / 22
------	---------

	green, blue, black, white)		A	B	Total	5, 6
		Bright dot	$N \leq 2$	$N \leq 2$	$N \leq 7$	
		Black / dark dot	$N \leq 3$	$N \leq 4$		
		Total dots	$N \leq 4$	$N \leq 5$		
		Two adjacent dots	Not allowed			
		Three or more adjacent dots	Not allowed			
External Inspection (Non-operating)	Scratch on the Polarizer	L (mm)	W (mm)	Acceptable number		2
		$L \leq 2.5$	$W \leq 0.1$	4		
		$L > 2.5$	$W > 0.1$	0		
	Dent or bubble on the polarizer	Dimension (mm)		Acceptable number		3
		$D \leq 0.5$		4		
		$D \leq 0.15$		Disregard		
	Foreign material on the polarizer	Dimension (mm)		Acceptable number		3
		$D \leq 0.5$		4		
		$D \leq 0.15$		Disregard		

Item		Specification / Description			Note
Touch Panel (If Present)	Scratch	L (mm)	W (mm)	Acceptable number	2
		$L \leq 10$	$W < 0.05$	Disregard	
			$0.05 \leq W < 0.1$	$N \leq 4$	
			$W \geq 0.1$	0	
	Foreign materials (Linear shape)	$L \leq 10$	$W < 0.05$	Disregard	2
			$0.05 \leq W < 0.1$	$N \leq 3$	
$W \geq 0.1$			0		

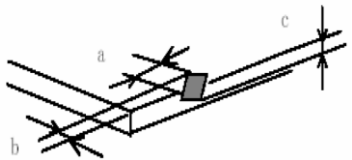
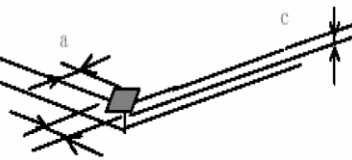
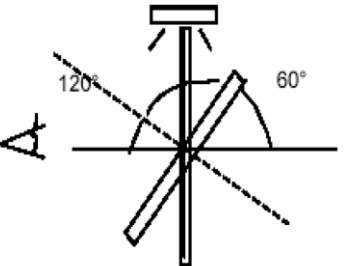
	Foreign materials (Circular shape)	Dimension (mm)	Acceptable number	3
		$D \leq 0.25$	Disregard	
		$0.25 < D \leq 0.5$	$N \leq 6$	
		$D > 0.5$	0	
	Glass chips		$a \leq 5\text{mm}$ $b \leq 3\text{mm}$ $c \leq t$ (t: Glass Thickness)	7
			$a \leq 3\text{mm}$ $b \leq 3\text{mm}$ $c \leq t$ (t: Glass thickness)	
	Newton's rings	(In case of doubtful situations only) Observe at 60° from the product surface for a while under a Fluorescent lamp. (3-Wavelength lamp) 	If Average Diameter $\leq (1/3)$ Touch Panel Area, Disregard.	7

Note 1: The definition of dot defect: The dot defect was judged after repair and the size of a defective dot with size over 1/2 of one standard dot is regarded as one defective dot.

Note 2:

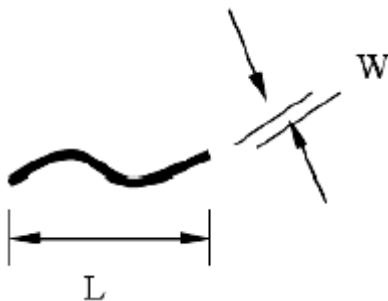

Note 3: Diameter - $D = (a + b) / 2$



Note 4: A bright dot is defined with 6% transmission ND filter as shown below:

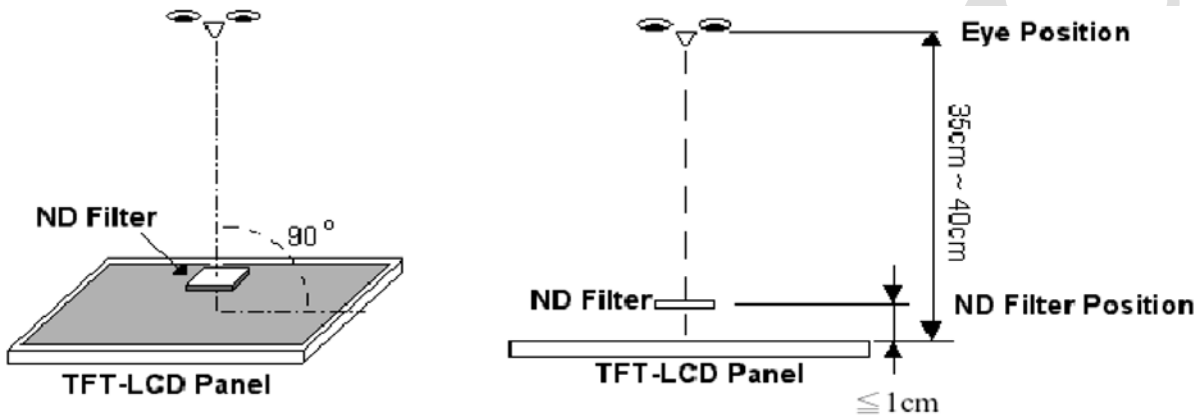

Note 5: Adjacent Dots:



Note 6:

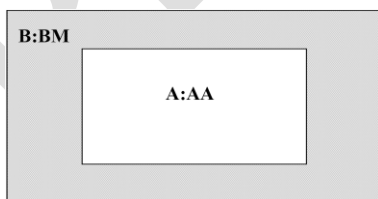

Note 7:

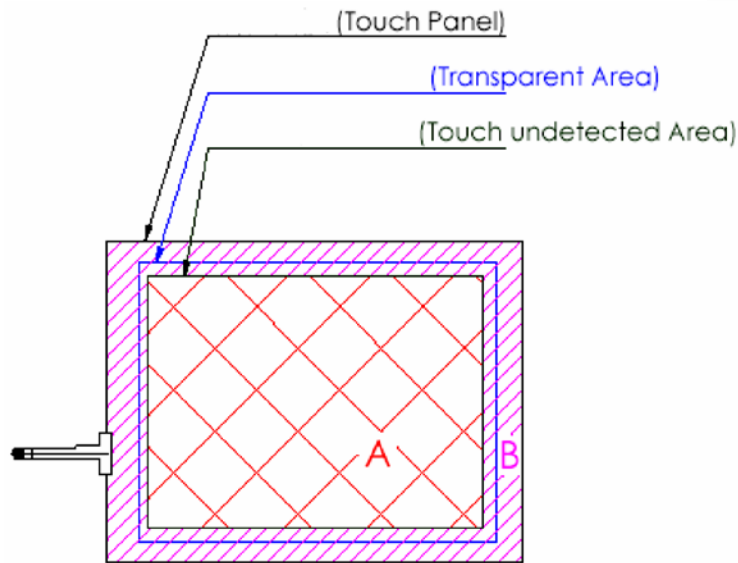

A: Area without any defect point effect on normal operation
B: Defects are not specified in this area

10 HANDLING PRECAUTIONS

Safety

If the LCD panel breaks, be careful not to get the liquid crystal fluid in your mouth or in your eyes. If the liquid crystal touches your skin or clothes, wash it off immediately using soap and plenty of water.

Mounting and Design

Place a transparent plate (e.g. acrylic, polycarbonate or glass) on the display surface to protect the display from external pressure. Leave a small gap between the transparent plate and the display surface. When assembling with a zebra connector, clean the surface of the pads with alcohol and keep the surrounding air very clean. Design the system so that no input signal is given unless the power supply voltage is applied.

Caution during LCD cleaning

Lightly wipe the display surface with a soft cloth soaked with Isopropyl alcohol, Ethyl alcohol or Trichlorotrifluoroethane. Do not wipe the display surface with dry or hard materials that will damage the polarizer surface. Do not use aromatic solvents (toluene and xylene), or ketonic solvents (ketone and acetone).

Caution against static charge

As the display uses C-MOS LSI drivers, connect any unused input terminals to VDD or VSS. Do not input any signals before power is turned on. Also, ground your body, work / assembly table and assembly equipment to protect against static electricity.

Packaging

Displays use LCD elements, and must be treated as such. Avoid strong shock and drop from a height.

Product No.	84-0204-000T	REV.A
-------------	--------------	-------

Page	21 / 22
------	---------

To prevent displays from degradation, do not operate or store them exposed directly to sunlight or high temperature / humidity.

Caution during operation

It is indispensable to drive the display within the specified voltage limit since excessive voltage shortens its life. Direct current causes an electrochemical reaction with remarkable deterioration of the display quality.

Give careful consideration to prevent direct current during ON/OFF timing and during operation.

Response time is extremely delayed at temperatures lower than the operating temperature range while, at high temperatures, displays become dark. However, this phenomenon is reversible and does not mean a malfunction or a display that has been permanently damaged. If the display area is pushed on hard during operation, some graphics will be abnormally displayed but returns to a normal condition after turning off the display once. Even a small amount of condensation on the contact pads (terminals) can cause an electrochemical reaction which causes missing rows and columns. Give careful attention to avoid condensation.

Storage

Store the display in a dark place where the temperature is $25^{\circ}\text{C} \pm 10^{\circ}\text{C}$ and the humidity below 50% RH.

Store the display in a clean environment, free from dust, organic solvents and corrosive gases.

Do not crash, shake or jolt the display (including accessories).