

LIQUID CRYSTAL DISPLAY MODULE

Product Specification

CUSTOMER	Standard	
PRODUCT NUMBER	DET101WSHLNT0-1B	
CUSTOMER APPROVAL		Date

INTERNAL APPROVALS		
Product Mgr	Doc. Control	Electr. Eng
Bruno	Luo	ZHE
Recaldini	Luo	KOU
Date: 23/07/12	Date: 23/07/12	Date: 23/07/12

Approval for Specification only

Approval for Specification and Sample

Product No.	DET101WSHLNT0-1B	REV. B

Page	1 / 25
------	--------

REVISION RECORD

Ver.	Date	Page	Chapt.	Comment
A	23-11-11			First Release
B	16-01-13	9 23	4.3 12	Remove LVDS Connector Add the EDID table

Product No.	DET101WSHLNT0-1B	REV. B

Page	2 / 25
------	--------

Contents

1	General Description and Features	4
1.1	Features	4
1.2	LCD Module	4
2	Absolute Max. Ratings.....	5
3	Electrical Characteristics	5
3.1	TFT-LCD Module	5
3.2	Switching Characteristics for LVDS Receiver	5
3.3	6-bit LVDS input Data Mapping	6
3.4	Backlight Unit	7
4	Input Terminal Pin Assignment	8
4.1	TFT Pin Assignment	8
4.2	Backlight Pin Assignment	9
5	Display Optical Characteristics	10
6	BLOCK DIAGRAM.....	13
6.1	TFTLCD Module	13
6.2	Pixel Format	13
7	AC Timing.....	14
7.1	Timing characteristics of input signals	14
7.2	POWER ON/OFF SEQUENCE	15
8	Reliability Test.....	16
9	Dimensional outlines.....	17
10	Incoming Inspection Standards	19
11	HANDLING & CAUTIONS	22
12	EDID TABLE.....	23

Product No.	DET101WSHLNT0-1B	REV. B

Page	3 / 25
------	--------

1 General Description and Features

DET101WSHLNT0-1B is Amorphous-TFT-LCD (Thin Film Transistor Liquid Crystal Display) module. This module is composed of a 10.1" TFT-LCD panel, a driving circuit and backlight system. This TFT LCD has a 10.1 (17:10) inch diagonally measured active display area with WSVGA (1024 horizontal by 600 vertical pixels) resolution. The following table described the features of DET101WSHLNT0-1B.

1.1 Features

- Construction: 10.1" a-Si TFT active matrix, White LED Backlight.
- Number of the Colors : 262K colors (R , G , B 6 bit digital each)
- Interface: One channel LVDS interface.
- RoHS Compliance.
- Halogen Free

1.2 LCD Module

Item	Specifications	Unit
LCD size	10.1 inch (Diagonal)	
Resolution	1024 x 3(RGB) x 600	dot
Pixel pitch	0.2715(W) x 0.2088(H)	mm
Active area	222.72(W) x 125.28(H)	mm
Module size	235.0(W) x 145.8(H) x 8.1(D)	mm
Surface treatment	Antiglare	
Color arrangement	RGB Vertical stripe	
interface	LVDS	
Brightness	1000 (Typ.)	cd/m ²
Weight	TBD	g
Display colors	262,144	colors
Display mode	Normally white	
Back-light	Single LED (Side-Light type)	

Product No.	DET101WSHLNT0-1B	REV. B

Page	4 / 25
------	--------

2 Absolute Max. Ratings

(GND = AVSS = 0V)

Item	Symbol	Values		UNIT	Note
		Min.	Max.		
Power voltage	VDD	-0.3	5.0	V	
Operation temperature	TOP	-20	70	°C	
Storage temperature	TST	-30	80	°C	

3 Electrical Characteristics

3.1 TFT-LCD Module

Item	Symbol	Values			UNIT	Note
		Min.	Typ.	Max.		
Power voltage	VDD	3.0	3.3	3.6	V	Note1
Current of power supply	IDD	-	0.3	-	A	VDD=3.3V Black pattern

Note 1: VDD-dip condition:

When $2.7V \leq VDD < 3.0V$, $t_d \leq 10ms$.

$VDD > 3.0V$, VDD-dip condition should be same as VDD-turn-con condition.

3.2 Switching Characteristics for LVDS Receiver

Item	Symbol	Min.	Typ.	Max.	Unit	Condition
Differential Input High Threshold	Vth	--	--	100	mV	VCM=1.2V
Differential Input Low Threshold	Vtl	-100	--	--	mV	
Input current	IIN	-10	--	+10	uA	
Differential input Voltage	VID	0.2	--	0.6	V	
Common Mode Voltage Offset	VCM	(VID /2)	--	2.4-(VID /2)	V	

Product No.	DET101WSHLNT0-1B	REV. B

Page	5 / 25
------	--------

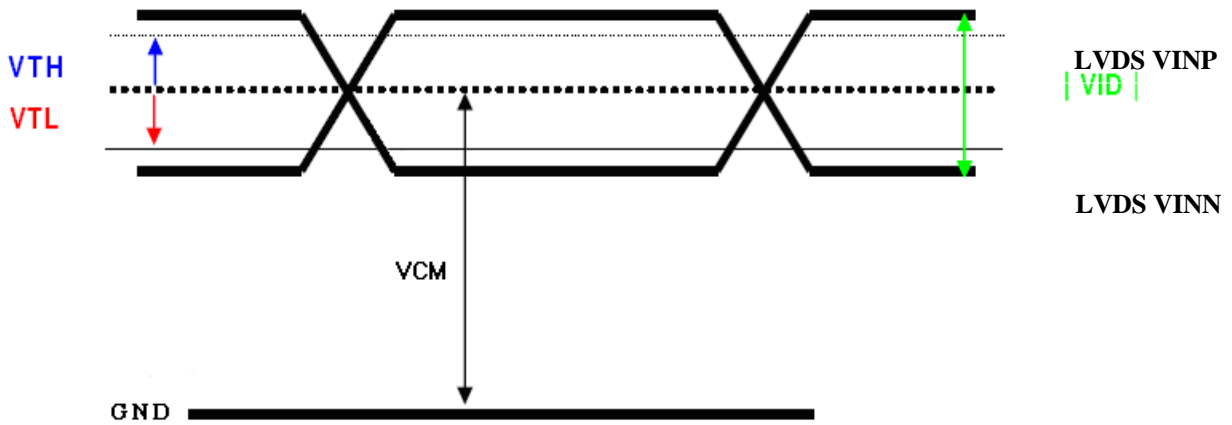

3.3 6-bit LVDS input Data Mapping

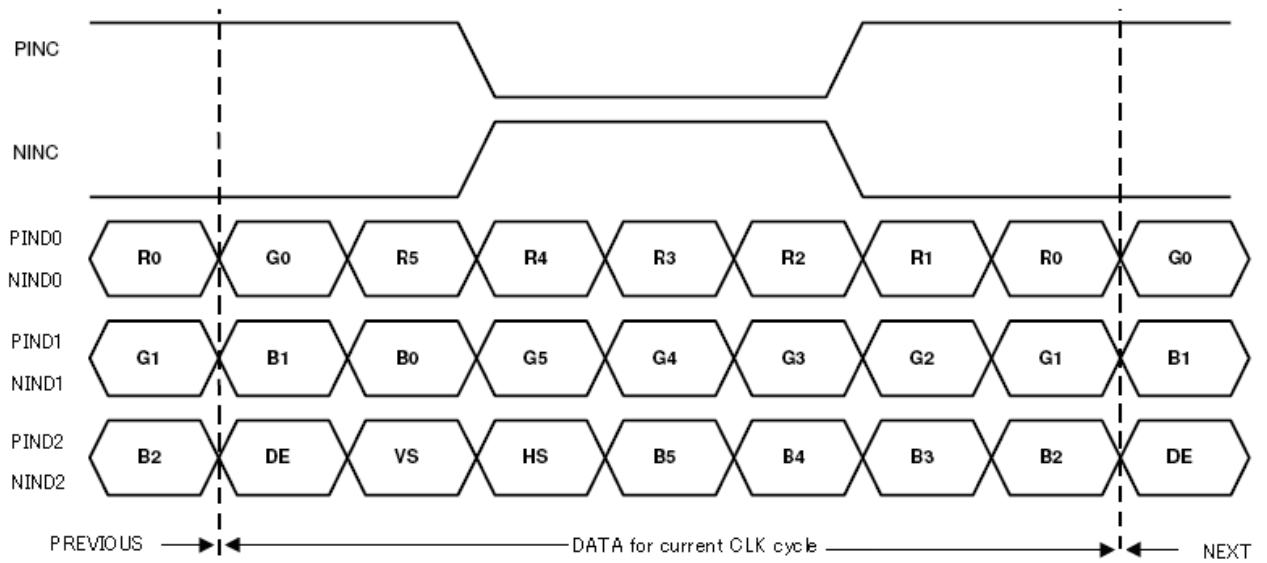

Product No.	DET101WSHLNT0-1B	REV. B

Page	6 / 25
------	--------

3.4 Backlight Unit

ITEM	SYMBOL	MIN	TYP	MAX	UNIT	NOTE
LED forward Voltage	Vf	--	21.0	24.6	V	I _{LED} =480mA, Ta=25°C
LED forward Current	I _{LED}	--	480	--	mA	Note1
LED Life Time(MTBF)		--	50K	--	Hr	Note2

Due to reduction of LCD active area, the LED Life Time changes proportionally.

Note 1: There are 6 Groups LED shown as below, V_{LED_A}-V_{LED_K}=21.0V, Ta=25°C

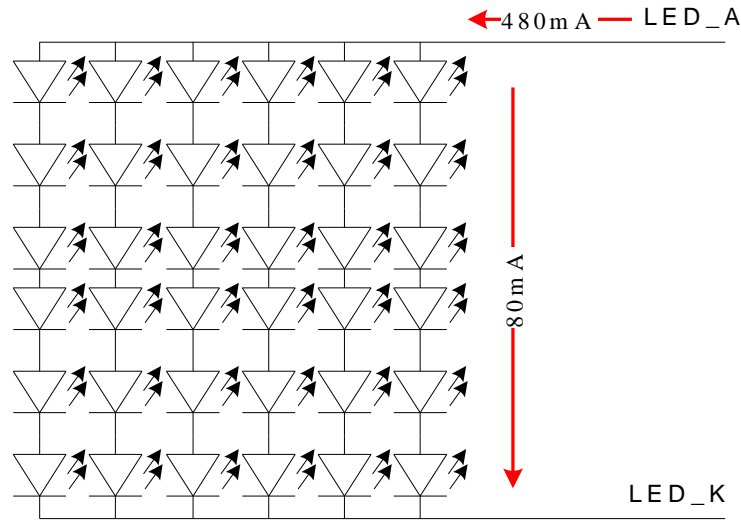

Note2: Condition: Ta=25°C, continuous lighting

Life time is estimated data.

Definitions of failure:

1. LCM brightness becomes half of the minimum value.
2. LED doesn't light normally.

When LCM is operated over 40°C ambient temperature, the I_{LED} should be

follow :

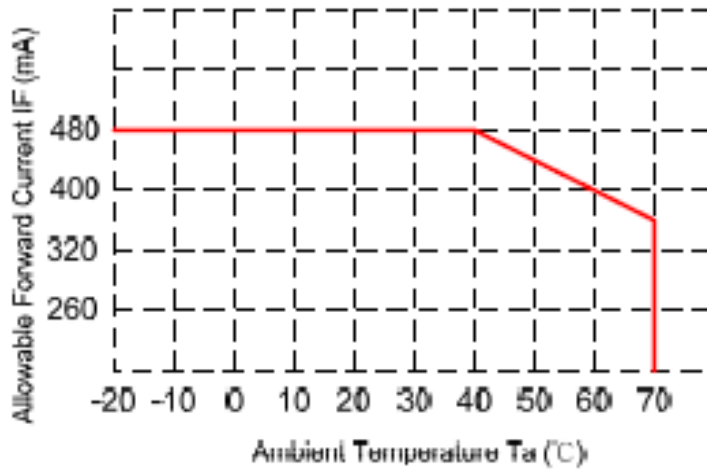

Product No.	DET101WSHLNT0-1B	REV. B

Page	7 / 25
------	--------

4 Input Terminal Pin Assignment

4.1 TFT Pin Assignment

CN2 Connector: JAE FI-XB30SSRL-HF16

Pin No.	Symbol	Description	Note
1	GND	Ground	
2	VDD	3.3V Power	
3	VDD	3.3V Power	
4	V_EDID	3.3V Power for EDID	
5	NC	No connection	
6	CLK_EDID	EDID Clock Input	
7	DATA_EDID	EDID Data Input	
8	RXIN0-	LVDS Signal - channel0-	
9	RXIN0+	LVDS Signal+ channel0+	
10	GND	Ground	
11	RXIN1-	Data Input channel1-	
12	RXIN1+	Data Input channel1+	
13	GND	Ground	
14	RXIN2-	Data Input channel2-	
15	RXIN2+	Data Input channel2+	
16	GND	Ground	
17	RXCLKIN-	Data Input CLK-	
18	RXCLKIN+	Data Input CLK+	
19	GND	Ground	
20	NC	No connection	
21	NC	No connection	
22	GND	Ground	

Product No.	DET101WSHLNT0-1B	REV. B

Page	8 / 25
------	--------

23	GND	Ground	
24	NC	No connection	
25	NC	No connection	
26	NC	No connection	
27	NC	No connection	
28	NC	No connection	
29	NC	No connection	
30	NC	No connection	

4.2 Backlight Pin Assignment

CN3 Connector (LED backlight): BHSR-02VS-1 (JST or equivalent)

Pin No.	Symbol	Description	Note
1	A	Anode for LED backlight (+21V, 480mA)	Red cable
2	K	Cathode for LED backlight	White cable

Product No.	DET101WSHLNT0-1B	REV. B

Page	9 / 25
------	--------

5 Display Optical Characteristics

Item	Symbol	Condition	Values			Unit	Note
			Min.	Typ.	Max.		
Viewing angle	θL	(CR \geq 10)	60	70	--	degree	Note1 Note2 Note6
	θR		60	70	--		
	θU		60	70	--		
	θD		40	50	--		
Response time	TR	Normal $\theta = \Phi = 0^\circ$	--	5	7	msec	Note3
	TF		--	20	28	msec	
Contrast ratio	CR		400	500	--	--	Note2
Color chromaticity	WX		0.26	0.31	0.36	--	Note1 Note4
	WY		0.28	0.33	0.38	--	
	RX		0.54	0.59	0.64		
	RY		0.28	0.33	0.38		
	GX		0.29	0.34	0.39		
	GY		0.54	0.59	0.64		
	BX		0.11	0.16	0.21		
	BY		0.05	0.1	0.15		
Luminance	L		800	1000	--	cd/m ²	Note4
Luminance uniformity	ΔL		70	--	--	%	Note5

Product No.	DET101WSHLNT0-1B	REV. B

Page	10 / 25
------	---------

5.1 Measuring surrounding

- dark room
- Ambient temperature : $25\pm 2^{\circ}\text{C}$
- 15min. warm-up time.

5.2 Measuring Equipment

The optical characteristics should be measured in dark room. After 30 minutes operation, the optical properties are measured at the center point of the LCD screen. (Response time is measured by Photo detector TOPCON BM-7 of view: 1° / Height : 120mm.)

Note 1: Definition of viewing angle range

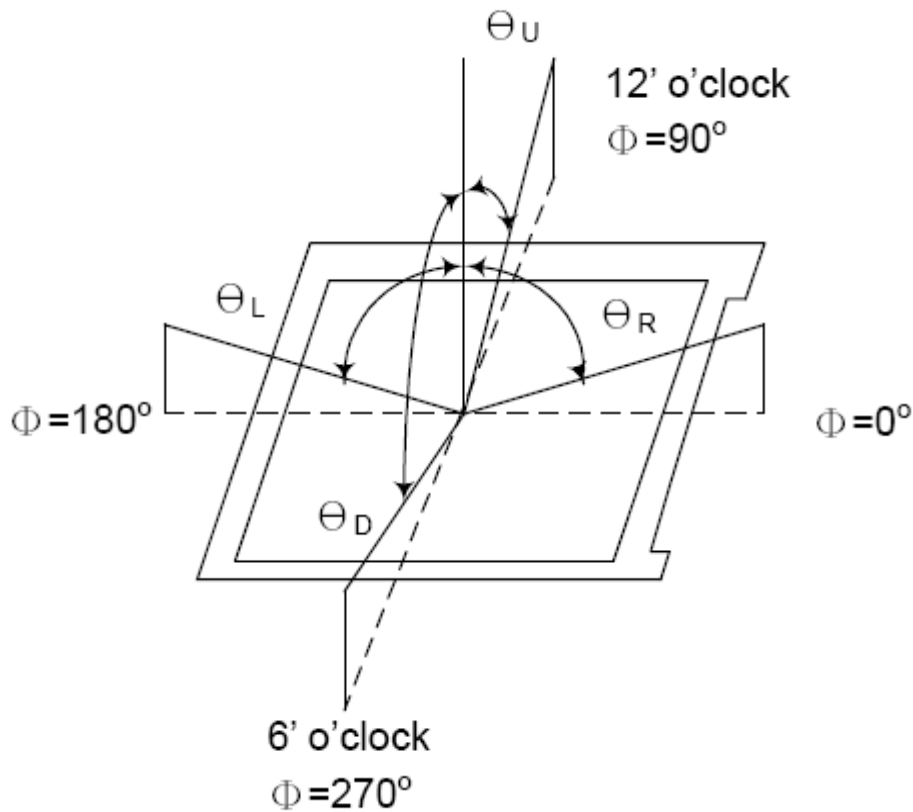

Note 2: Definition of Contrast Ratio (CR):
measured at the center point of panel

$$\text{CR} = \frac{\text{Luminance with all pixels white}}{\text{Luminance with all pixels black}}$$

Product No.	DET101WSHLNT0-1B	REV. B

Page	11 / 25
------	---------

Note 3: Definition of Response time: Sum of TR and TF

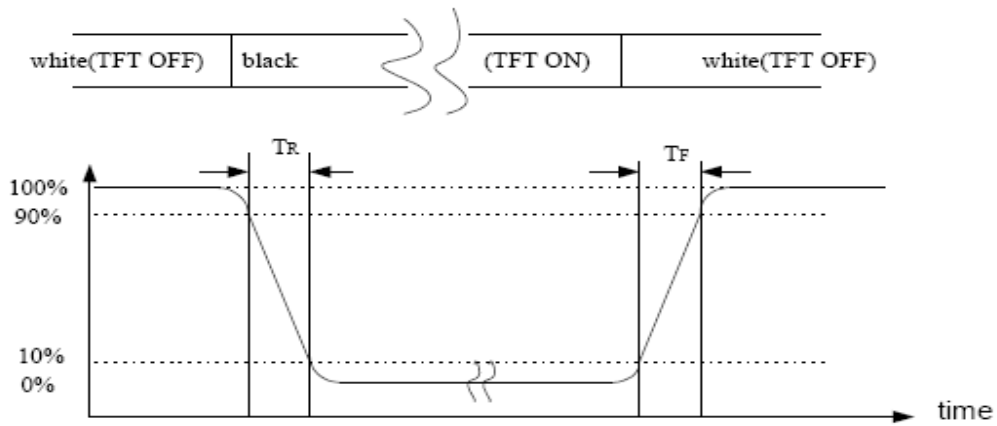

Note 4: Definition of optical measurement setup

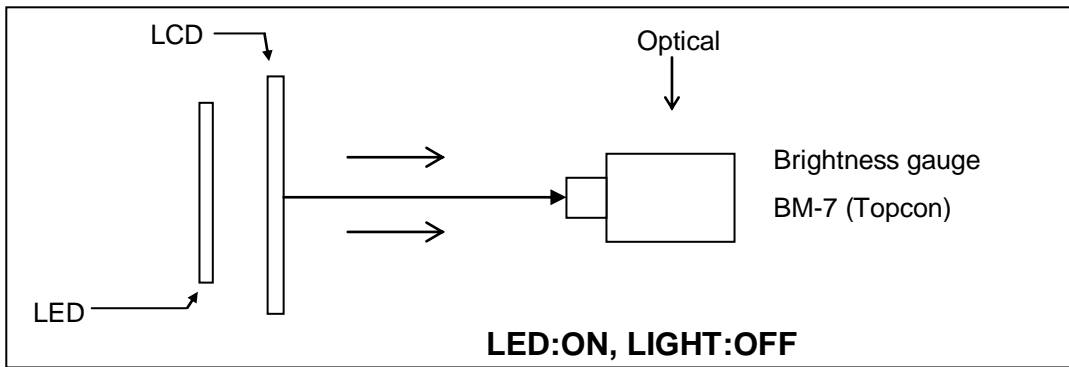

Note 5: Definition of brightness uniformity

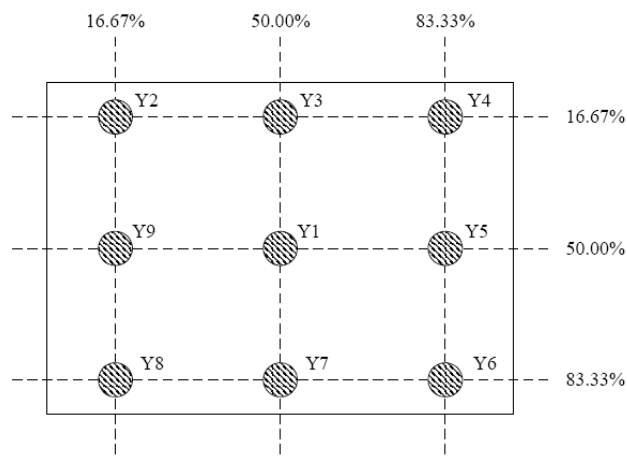

(Min Luminance of 9 points)

$$\text{Luminance uniformity} = \frac{\text{Min Luminance of 9 points}}{\text{Max Luminance of 9 points}} \times 100\%$$

(Max Luminance of 9 points)

Note 6: Rubbing Direction (The different Rubbing Direction will cause the different optima view direction).

Product No.	DET101WSHLNT0-1B	REV. B

Page	12 / 25
------	---------

6 BLOCK DIAGRAM

6.1 TFTLCD Module

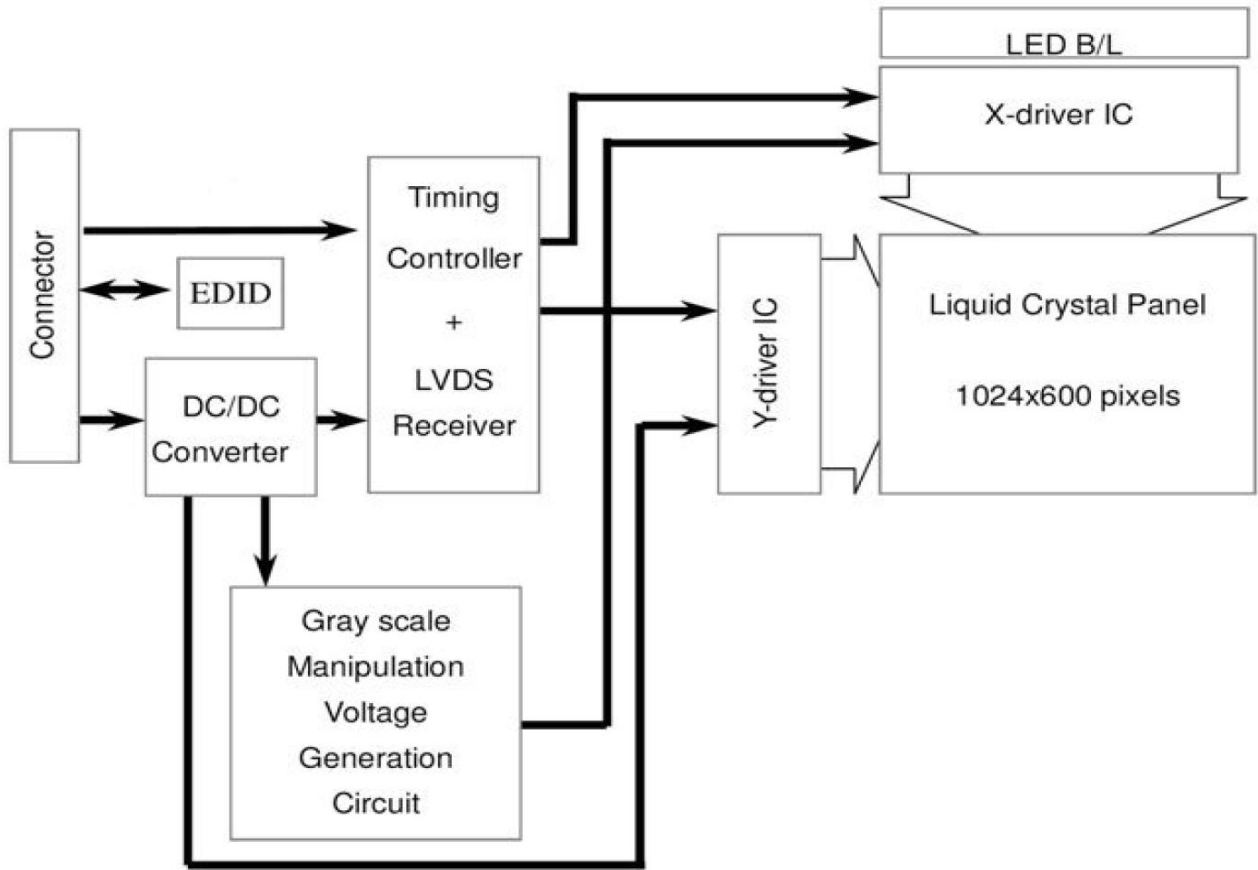

6.2 Pixel Format

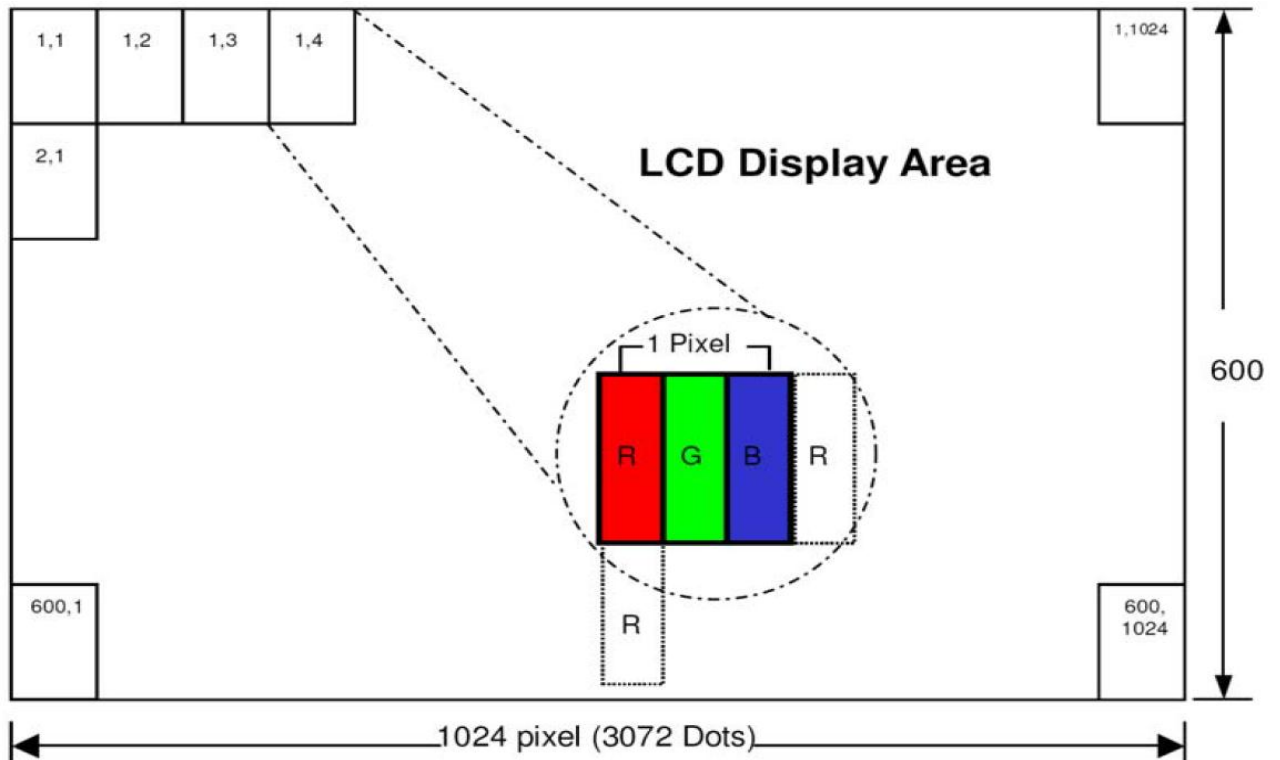

Product No.	DET101WSHLNT0-1B	REV. B

Page	13 / 25
------	---------

7 AC Timing

7.1 Timing characteristics of input signals

ITEM			SYMBOL	MIN	TYP	MAX	UNIT	
LVDS input signal sequence	Frame Rate		clk	41	51.2	57	MHz	
LCD input signal sequence (input LVDS Transmitter)	DENA	Horizontal	Horizontal Total Timing	t_H	1214	1344	1364	t_{CLK}
			Horizontal effective Timing	t_{HA}	1024			t_{CLK}
			Horizontal Blank Timing	t_{HB}	190	320	340	t_{CLK}
	Vertical	Vertical total Time	t_V	615	635	645	t_H	
		Vertical effective Time	t_{VA}	600			t_H	
		Vertical Blank Time	t_{VB}	15	35	45	t_H	

Horizontal timing sequence

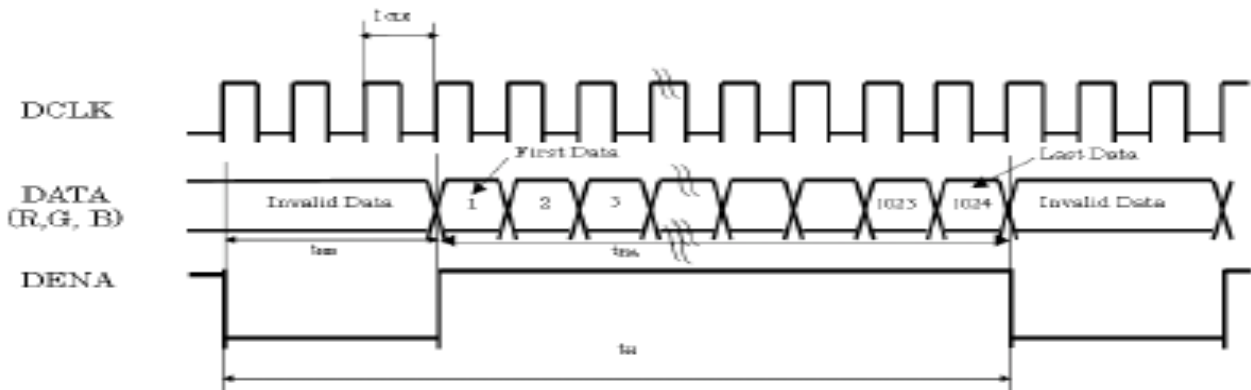

Vertical timing sequence

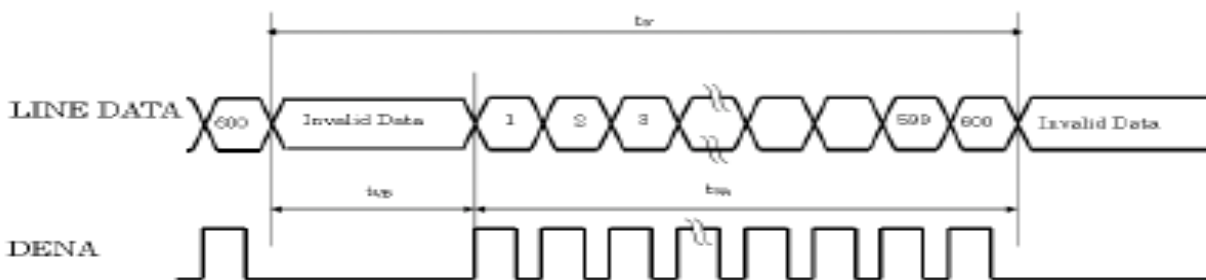

Product No.	DET101WSHLNT0-1B	REV. B

Page	14 / 25
------	---------

7.2 POWER ON/OFF SEQUENCE

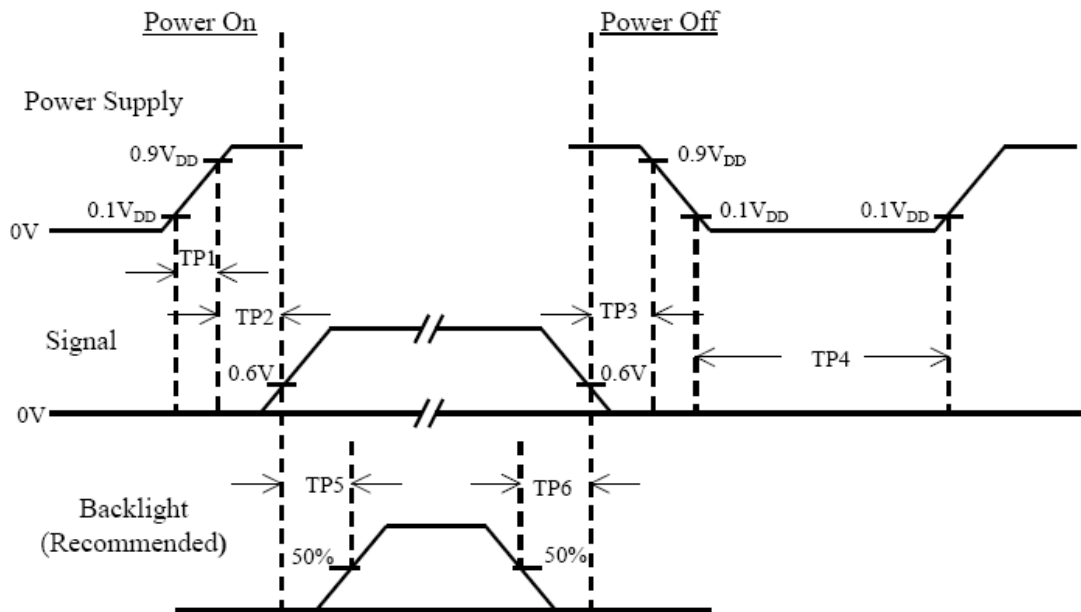

Item	Min.	Typ.	Max.	Unit	Remark
TP1	0.5	--	10	msec	
TP2	0	--	50	msec	
TP3	0	--	50	msec	
TP4	500	--	--	msec	
TP5	200	--	--	msec	
TP6	200	--	--	msec	

Note :

- (1) The supply voltage of the external system for the module input should be the same as the definition of VDD.
- (2) Apply the lamp voltage within the LCD operation range. When the back-light turns on before the LCD operation or the LCD turns off before the back-light turns off, the display may momentarily become white.
- (3) In case of VDD = off level, please keep the level of input signal on the low or keep a high impedance.
- (4) TP4 should be measured after the module has been fully discharged between power off and on period.
- (5) Interface signal shall not be kept at high impedance when the power is on.

Product No.	DET101WSHLNT0-1B	REV. B

Page	15 / 25
------	---------

8 Reliability Test

Item	Test Conditions	Note
High Temperature Storage	Ta = 80°C 240 hrs	
Low Temperature Storage	Ta = -30°C 240 hrs	
High Temperature Operation	Ts = 70°C 240 hrs	
Low Temperature Operation	Ta = -20°C 240 hrs	
Thermal Shock	-30°C /30 min ~ +80°C /30 min 100 cycles	

Storage / Operating temperature

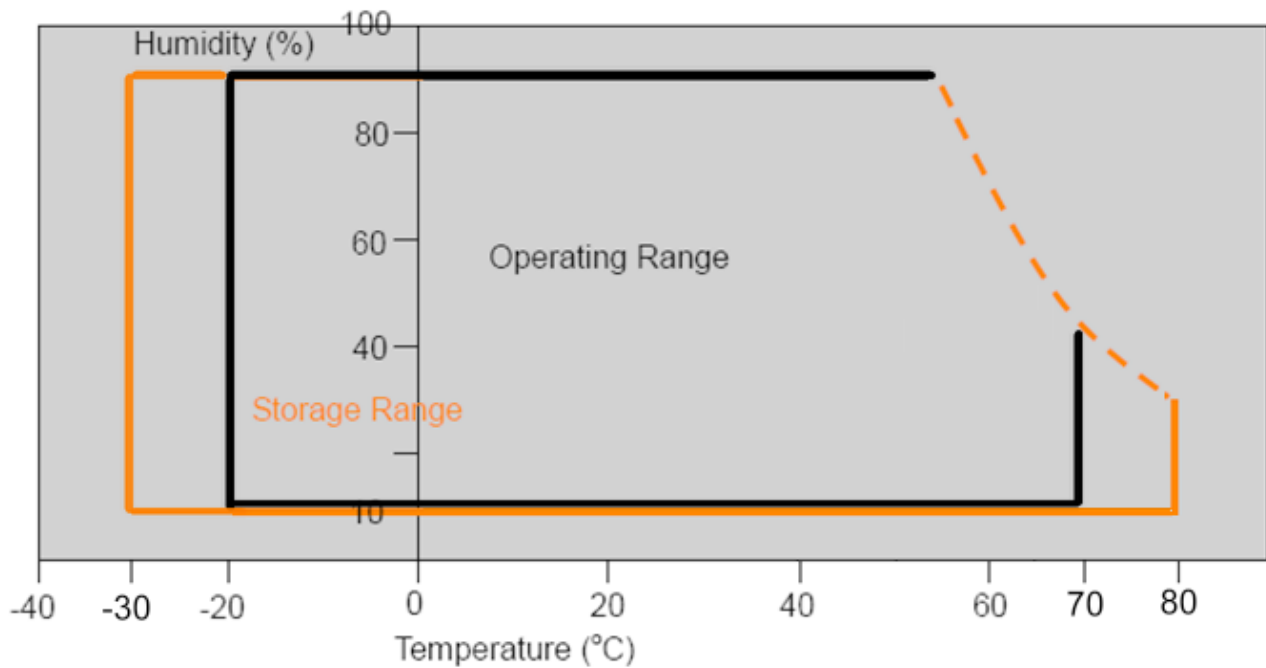

Note: Max wet bulb temp=39°C

Product No.	DET101WSHLNT0-1B	REV. B

Page	16 / 25
------	---------

9 Dimensional outlines

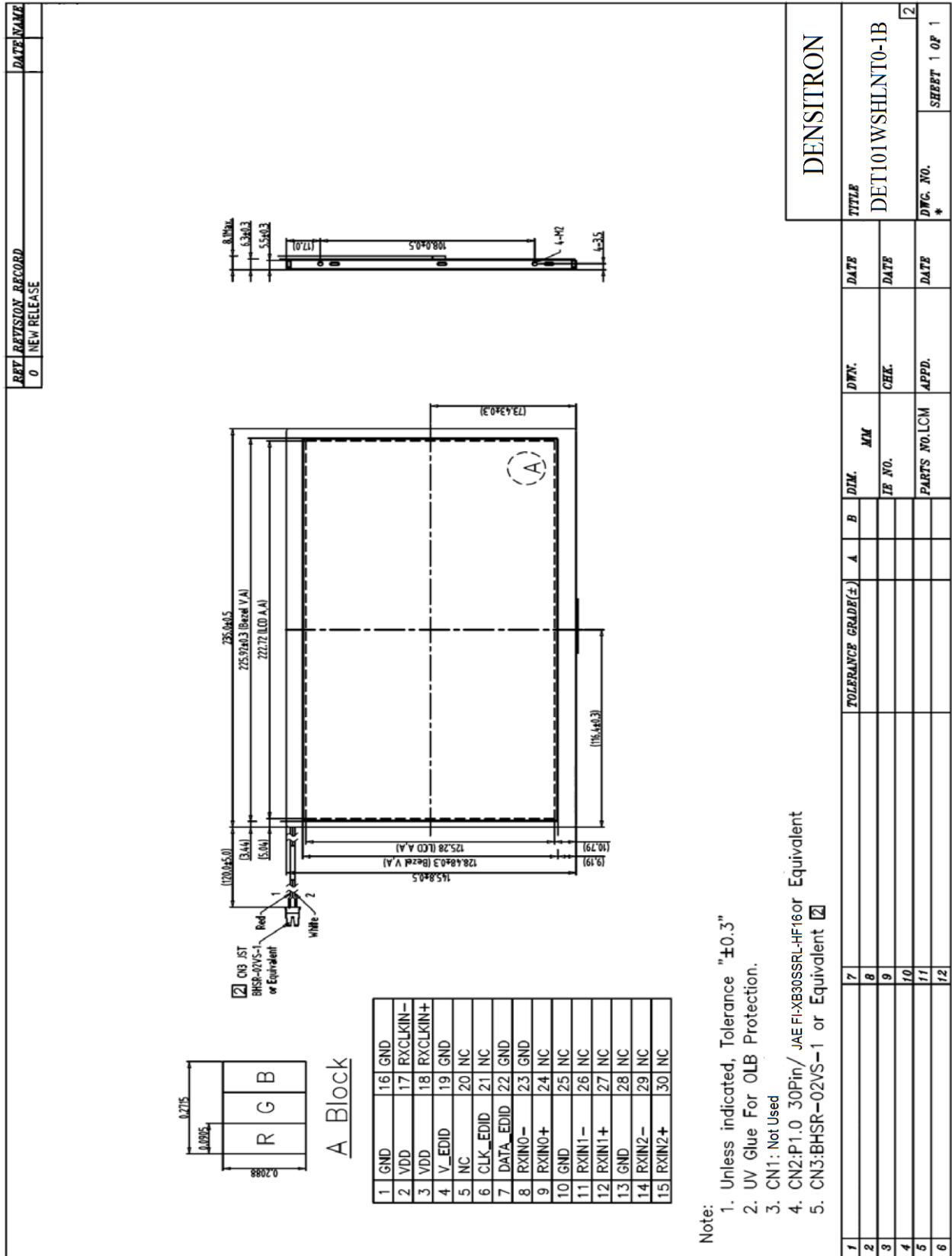

Product No.	DET101WSHLNT0-1B	REV. B

Page	17 / 25
------	---------

REV	REVISION RECORD	DATE	NAME
0			

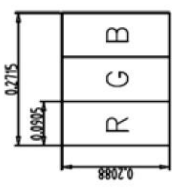

A Block

1	GND	16	GND
2	VDD	17	RXCLKIN-
3	VDD	18	RXCLKIN+
4	V_EDID	19	GND
5	NC	20	NC
6	CLK_EDID	21	NC
7	DATA_EDID	22	GND
8	RXINO-	23	GND
9	RXINO+	24	NC
10	GND	25	NC
11	RXIN1-	26	NC
12	RXIN1+	27	NC
13	GND	28	NC
14	RXIN2-	29	NC
15	RXIN2+	30	NC

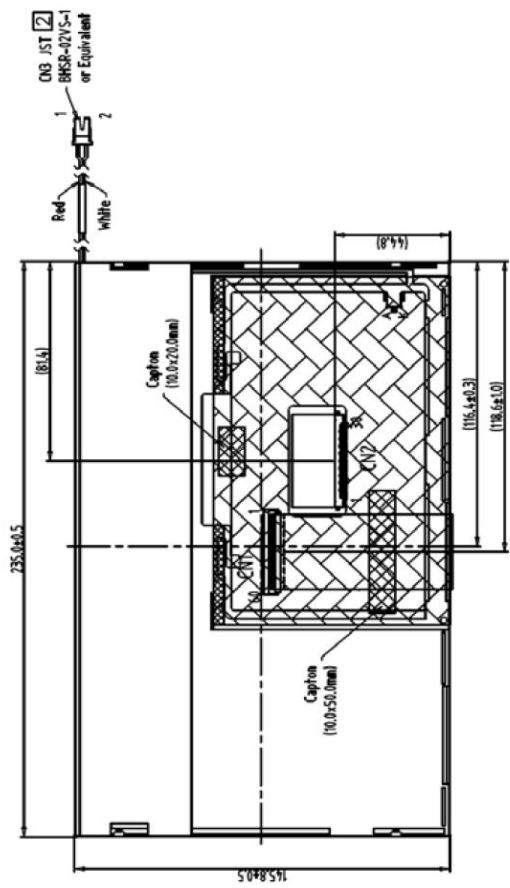

Back view

- Note:
1. Unless indicated, Tolerance "±0.3"
 2. UV Glue For OLB Protection.
 3. CN1: Not Used
 4. CN2: P1.0 30Pin/ JAE F1XB30SSRL-HF160T Equivalent
 5. CN3: BHSR-02VS-1 or Equivalent

DENSITRON			
TITLE	DET101WSHLNT0-1B	DATE	2
DWC. NO.	*	DATE	
SHEET	1 OF 1	DATE	
TOLERANCE GRADE(±)	A B	DFN.	
		CHK.	
		APPD.	
		PARTS NO.	
		MM	
		IE NO.	

Product No.	DET101WSHLNT0-1B	REV. B

Page	18 / 25
------	---------

10 Incoming Inspection Standards

10.1 Scope

Specifications contain

- Display Quality Evaluation
- Mechanics Specification

10.2 Sampling Plan

Unless there is other agreement, the sampling plan for incoming inspection shall follow MIL-STD-105E LEVEL II.

- Lot size: Quantity per shipment as one lot (different model as different lot).
- Sampling type: Normal inspection, single sampling.
- Sampling level: Level II.
- AQL: Acceptable Quality Level
 - Major defect: AQL=0.65
 - Minor defect: AQL=1.0

10.3 Panel inspection Condition

10.3.1 Environment:

Room Temperature: 25±5°C.

Humidity: 65±5% RH.

Illumination: 300 ~ 700 Lux.

10.3.2 Inspection Distance:

35-40 cm

10.3.3 Inspection Angle:

The vision of inspector should be perpendicular to the surface of the Module.

10.3.4 Inspection time :

Perceptibility Test Time: 20 seconds max.

10.4 Display Quality

10.4.1 Function Related:

The function defects of line defect, abnormal display, and no display are considered Major defects.

Product No.	DET101WSHLNT0-1B	REV. B

Page	19 / 25
------	---------

10.4.2 Bright/Dark Dots:

Defect Type / Specification	G0 Grade	A Grade
Bright Dots	0	$N \leq 3$
Dark Dots	0	$N \leq 4$
Total Bright and Dark Dots	0	$N \leq 6$

[Note 1]

Judge defect dot and adjacent dot as following.

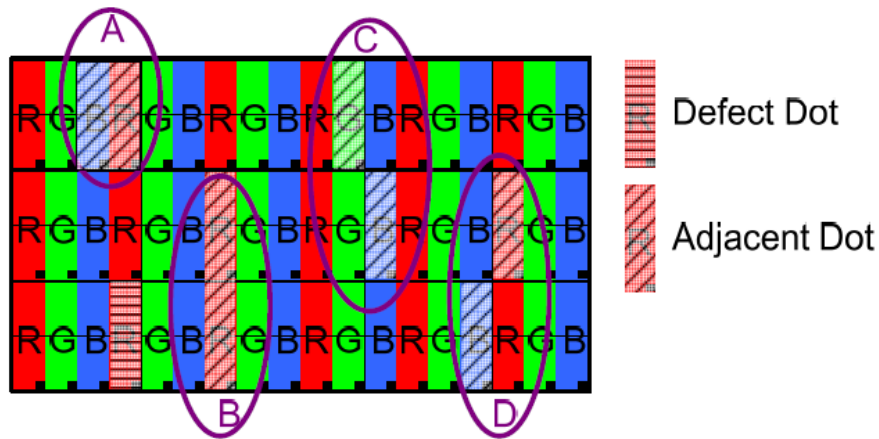

- (1) One pixel consists of 3 sub-pixels, including R,G, and B dot.(Sub-pixel = Dot)
- (2) The definition of dot: The size of a defective dot over 1/2 of whole dot is regarded as one defective dot.
- (3) Allow above (as A, B, C and D status) adjacent defect dots, including bright and dart adjacent dot. And they will be counted 2 defect dots in total quantity.
- (4) Defects on the Black Matrix, out of Display area, are not considered as a defect or counted.
- (5) There should be no distinct non-uniformity visible through 6% ND Filter within 2 sec inspection times.

10.4.3 Visual Inspection specifications

Defect Type	Specification	Count(N)
Dot Shape (Particle、Scratch and Bubbles in display area)	$D \leq 0.25\text{mm}$	Ignored
	$0.25\text{mm} < D \leq 0.5\text{mm}$	$N \leq 3$
	$D > 0.5\text{mm}$	$N=0$
Line Shape (Particles、Scratch、Lint and Bubbles in display area)	$W \leq 0.07\text{mm}$	Ignored
	$0.07\text{mm} < W \leq 0.1\text{mm}$, $L \leq 5\text{mm}$	$N \leq 3$
	$W > 0.1\text{mm}$, $L > 5\text{mm}$	$N=0$

Product No.	DET101WSHLNT0-1B	REV. B

Page	20 / 25
------	---------

(Particles, Scratch, Lint and Bubbles in display area)	0.07mm<W 0.1mm,L 5mm	N 3
	W>0.1mm , L>5mm	N=0

[Note 2] W: Width [mm], L: Length [mm], N: Number, φ: Average Diameter

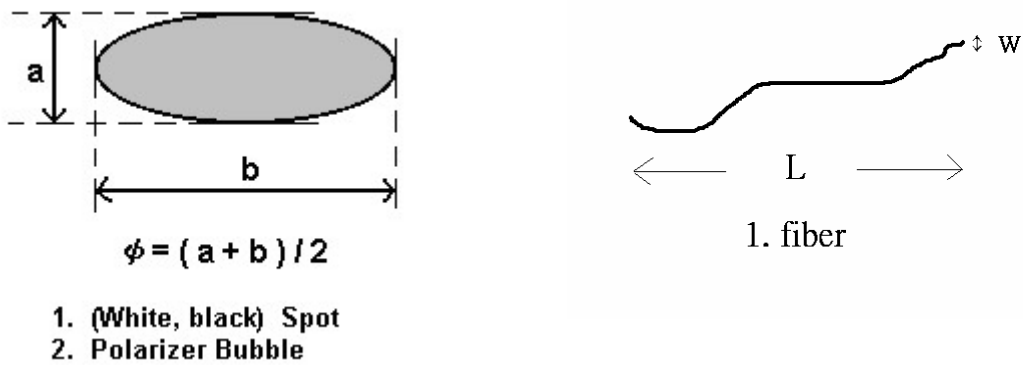

[Note 3] Bright dot is defined through 3% transmission ND Filter as following.

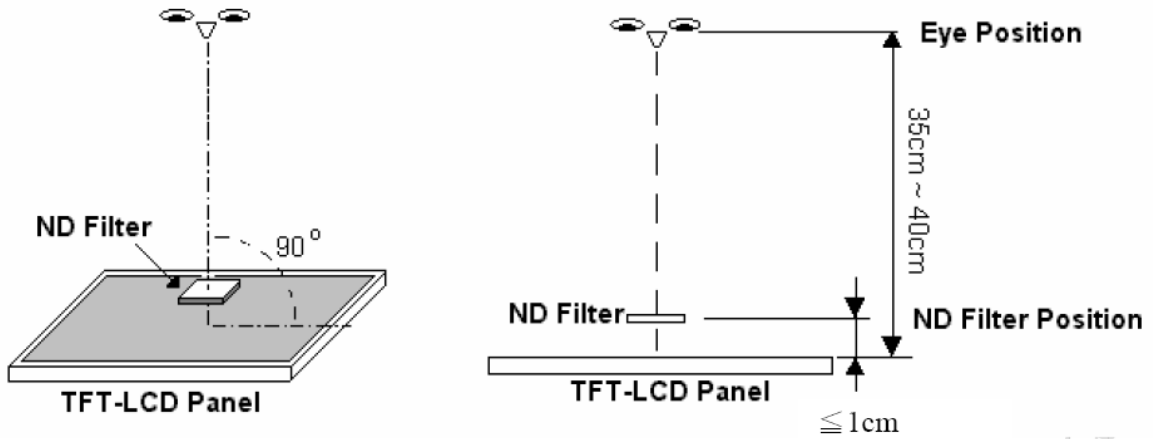

Product No.	DET101WSHLNT0-1B	REV. B

Page	21 / 25
------	---------

11 HANDLING & CAUTIONS

11.1 Cautions when taking out the module

Pick the pouch only, when taking out module from a shipping package.

11.2 Cautions for handling the module

11.2.1 As the electrostatic discharges may break the LCD module, handle the LCD module with care. Peel a protection sheet off from the LCD panel surface as slowly as possible.

11.2.2 As the LCD panel and backlight element are made from fragile glass material, impulse and pressure to the LCD module should be avoided.

11.2.3 As the surface of the polarizer is very soft and easily scratched, use a soft dry cloth without chemicals for cleaning.

11.2.4 Do not pull the interface connector in or out while the LCD module is operating.

11.2.5 Put the module display side down on a flat horizontal plane.

11.2.6 Handle connectors and cables with care.

11.3 Cautions for the operation

11.3.1 When the module is operating, do not lose MCLK, DE signals. If any one of these signals were lost, the LCD panel would be damaged.

11.3.2 Obey the supply voltage sequence. If wrong sequence were applied, the module would be damaged.

11.4 Cautions for the atmosphere

11.4.1 Dewdrop atmosphere should be avoided.

11.4.2 Do not store and/or operate the LCD module in a high temperature and/or humidity atmosphere. Storage in an electro-conductive polymer-packing pouch and under relatively low temperature atmosphere is recommended.

11.5 Cautions for the module characteristics

11.5.1 Do not apply fixed pattern data signal to the LCD module at product aging.

11.5.2 Applying fixed pattern for a long time may cause image sticking.

11.6 Other cautions

11.6.1 Do not disassemble and/or re-assemble LCD module.

11.6.2 Do not re-adjust variable resistor or switch etc.

11.6.3 When returning the module for repair or etc, please pack the module not to be broken. We recommend using the original shipping packages.

11.6.4 Densitron Technologies will provide one year warrantee for all products and three months warrantee for all repairing products.

Product No.	DET101WSHLNT0-1B	REV. B

Page	22 / 25
------	---------

12 EDID TABLE

EDID Table of 1024600L

Byte# (Decimal)	Byte# (HEX)	Field Name & Comments	Value (HEX)	Value (BIN)	Value (DEC)
0	00	Header	00	00000000	0
1	01	Header	FF	11111111	255
2	02	Header	FF	11111111	255
3	03	Header	FF	11111111	255
4	04	Header	FF	11111111	255
5	05	Header	FF	11111111	255
6	06	Header	FF	11111111	255
7	07	Header	00	00000000	0
8	08	ISA Manufacture Code LSB(3 character ID = AM	05	00000101	5
9	09	Compressed ASCII	B0	10110000	176
10	0A	Product Code "1001"	60	01100000	96
11	0B	Hex, LSB first	12	00010010	18
12	0C	LCD module Serial No-Preferred but Optional	58	01011000	88
13	0D	LCD module Serial No-Preferred but Optional	A2	10100010	162
14	0E	LCD module Serial No-Preferred but Optional	0F	00001111	15
15	0F	LCD module Serial No-Preferred but Optional	00	00000000	0
16	10	Week of manufacture=25	19	00011001	25
17	11	Year of manufacture=2012	16	00010110	22
18	12	EDID Structure Version#=1	01	00000001	1
19	13	EDID revision#=3	03	00000011	3
20	14	Video input definition=Digital input, CRGB	80	10000000	128
21	15	Max H image size=22cm	16	00010110	22
22	16	Max V image size=13cm	0D	00001101	13
23	17	Display Gamma=2.2	78	01111000	120
24	18	Feature support(DPMS)=Active off, RGB color	0A	00001010	10
25	19	Red/green low bits(10000110)	86	10000110	134
26	1A	Blue/white low bits(00100110)	26	00100110	38
27	1B	Red x, Red x=0.592	97	10010111	151
28	1C	Red y, Red y=0.340	57	01010111	87
29	1D	Green x, Green x=0.341	57	01010111	87
30	1E	Green y, Green y=0.592	97	10010111	151
31	1F	Blue x, Blue x=0.156	28	00101000	40
32	20	Blue y, Blue y=0.127	20	00100000	32
33	21	White x, White x=0.321	52	01010010	82
34	22	White y, White y=0.33	54	01010100	84
35	23	Established timing 1	00	00000000	0
36	24	Established timing 2	00	00000000	0
37	25	Manufacturer's timings	00	00000000	0
38	26	Standard timing#1 was not used	01	00000001	1
39	27		01	00000001	1
40	28	Standard timing#2 was not used	01	00000001	1
41	29		01	00000001	1
42	2A	Standard timing#3 was not used	01	00000001	1
43	2B		01	00000001	1
44	2C	Standard timing#4 was not used	01	00000001	1
45	2D		01	00000001	1
46	2E	Standard timing#5 was not used	01	00000001	1
47	2F		01	00000001	1
48	30	Standard timing#6 was not used	01	00000001	1
49	31		01	00000001	1
50	32	Standard timing#7 was not used	01	00000001	1
51	33		01	00000001	1
52	34	Standard timing#8 was not used	01	00000001	1
53	35		01	00000001	1
54	36	Detailed timing/monitor(descriptor#1)	00	00000000	0
55	37	1024x600@60Hz: Pixel Clock=51.2MHz	14	00010100	20
56	38	Horizontal active= 1024 pixels (L8b)	00	00000000	0
57	39	Horizontal blanking= 320 pixels (L8b)	40	01000000	64

Product No.	DET101WSHLNT0-1B	REV. B

Page	23 / 25
------	---------

58	3A	HA(U4b): HB(U4b)	41	01000001	65
59	3B	Vertical active= 600 lines (L8b)	58	01011000	88
60	3C	Vertical blanking= 35 lines (L8b)	23	00100011	35
61	3D	HA(U4b): HB(U4b)	20	00100000	32
62	3E	H sync. Offset=53 pixels	35	00110101	53
63	3F	H sync. Width=35 pixels	23	00100011	35
64	40	V sync. Offset=4 lines	45	01000101	69
65	41	V sync. Width=5 lines	00	00000000	0
66	42	H image size= 220 mm (L8b)	DC	11011100	220
67	43	V image size= 129 mm (L8b)	81	10000001	129
68	44	Horizontal Image (U4b): Vertical Image (U4b)	00	00000000	0
69	45	No Horizontal Border=0	00	00000000	0
70	46	No Vertical Border=0	00	00000000	0
71	47	Non-interlaced, Normal display, No stereo, Digital separate sync, H/V pol Negatives	19	00011001	25
72	48	Detailed timing/monitor(descriptor#2)	44	01000100	68
73	49	1024×600 @65Hz: Pixel Clock= 57MHz	16	00010110	22
74	4A	Horizontal active= 1024 pixels (L8b)	00	00000000	0
75	4B	Horizontal blanking= 340 pixels (L8b)	54	01010100	84
76	4C	HA(U4b): HB(U4b)	41	01000001	65
77	4D	Vertical active= 600 lines (L8b)	58	01011000	88
78	4E	Vertical blanking= 45 lines (L8b)	2D	00101101	45
79	4F	HA(U4b): HB(U4b)	20	00100000	32
80	50	H sync. Offset=93 pixels	5D	01011101	93
81	51	H sync. Width=35 pixels	23	00100011	35
82	52	V sync. Offset=17 lines	15	00010101	21
83	53	V sync. Width=5 lines	04	00000100	4
84	54	H image size= 220 mm (L8b)	DC	11011100	220
85	55	V image size= 129 mm (L8b)	81	10000001	129
86	56	Horizontal Image (U4b): Vertical Image (U4b)	00	00000000	0
87	57	No Horizontal Border=0	00	00000000	0
88	58	No Vertical Border=0	00	00000000	0
89	59	EDID Module revision	00	00000000	0
90	5A	Flag	00	00000000	0
91	5B	Flag	00	00000000	0
92	5C	Flag	00	00000000	0
93	5D	Dummy Descriptor	FE	11111110	254
94	5E	Flag	00	00000000	0
95	5F	PC Maker P/N 1st Character =M	00	00000000	0
96	60	PC Maker P/N 2nd Character =3	00	00000000	0
97	61	PC Maker P/N 3rd Character =4	00	00000000	0
98	62	PC Maker P/N 4th Character =9	00	00000000	0
99	63	PC Maker P/N 5th Character =5	00	00000000	0
100	64	LCD Supplier EEDID Revision # = 1.0	00	00000000	0
101	65	Manufacture P/N = 1	00	00000000	0
102	66	Manufacture P/N = 5	00	00000000	0
103	67	Manufacture P/N = P	00	00000000	0
104	68	Manufacture P/N = X	00	00000000	0
105	69	Manufacture P/N = 1	00	00000000	0
106	6A	Manufacture P/N = 4	00	00000000	0
107	6B	Manufacture P/N(If<13 char, then terminate with ASCII code, set remaining=20h)	00	00000000	0
108	6C	Flag	00	00000000	0
109	6D	Flag	00	00000000	0
110	6E	Flag	00	00000000	0
111	6F	Data Type Tag	FE	11111110	254
112	70	Flag	00	00000000	0
113	71	SMBUS Value = 20 nit	00	00000000	0
114	72	SMBUS Value = 28 nit	00	00000000	0
115	73	SMBUS Value = 40 nit	00	00000000	0
116	74	SMBUS Value = 56 nit	00	00000000	0

Product No.	DET101WSHLNT0-1B	REV. B

Page	24 / 25
------	---------

117	75	SMBUS Value = 79 nit	00	00000000	0
118	76	SMBUS Value = 111 nit	00	00000000	0
119	77	SMBUS Value = 156 nit	00	00000000	0
120	78	SMBUS Value = max nit	00	00000000	0
121	79	Number of LVDS channels=1	01	00000001	1
122	7A	Panel Self Test (00-Not Present, 01-Present)	00	00000000	0
123	7B	(If<13 char, then terminate with ASCII code 0Ah, set remaining char=20h)	00	00000000	0
124	7C	(If<13 char, then terminate with ASCII code 0Ah, set remaining char=20h)	00	00000000	0
125	7D	(If<13 char, then terminate with ASCII code 0Ah, set remaining char=20h)	00	00000000	0
126	7E	Extension Flag = 00	00	00000000	0
127	7F	Checksum	2E	00101110	46

Product No.	DET101WSHLNT0-1B	REV. B

Page	25 / 25
------	---------