

# LIQUID CRYSTAL DISPLAY MODULE

## Product Specification

<b>CUSTOMER</b>	<b>Standard</b>
<b>CUSTOMER PART NUMBER</b>	
<b>PRODUCT NUMBER</b>	<b>DET28QVF1J-A</b>

Product Mgr	Design Eng
<b>Bruno</b>	<b>Sunny</b>
Date: 17-March-15	Date: 17-March-15

## TABLE OF CONTENTS

<b>1</b>	<b>MAIN FEATURES</b> .....	<b>4</b>
<b>2</b>	<b>MECHANICAL SPECIFICATION</b> .....	<b>5</b>
2.1	MECHANICAL CHARACTERISTICS.....	5
2.2	MECHANICAL DRAWING.....	6
<b>3</b>	<b>ELECTRICAL SPECIFICATION</b> .....	<b>7</b>
3.1	ABSOLUTE MAXIMUM RATINGS.....	7
3.2	ELECTRICAL CHARACTERISTICS.....	7
3.3	INTERFACE PIN ASSIGNMENT .....	8
3.4	BLOCK DIAGRAM .....	9
3.5	TIMING CHARACTERISTICS .....	10
3.6	COMMAND TABLE .....	12
3.7	POWER SEQUENCE .....	14
<b>4</b>	<b>OPTICAL SPECIFICATION</b> .....	<b>16</b>
4.1	OPTICAL CHARACTERISTICS.....	16
<b>5</b>	<b>BACKLIGHT SPECIFICATION</b> .....	<b>18</b>
5.1	LED DRIVING CONDITIONS .....	18
5.2	LED CIRCUIT .....	18
<b>6</b>	<b>TOUCH PANEL CHARACTERISTICS</b> .....	<b>19</b>
6.1	ELECTRICAL CHARACTERISTICS.....	19
6.2	MECHANICAL CHARACTERISTICS.....	19
6.3	TOUCH PANEL PIN ASSIGNMENT.....	19
<b>7</b>	<b>QUALITY ASSURANCE SPECIFICATION</b> .....	<b>20</b>
7.1	DELIVERY INSPECTION STANDARDS .....	20
7.2	DEALING WITH CUSTOMER COMPLAINTS.....	26
<b>8</b>	<b>RELIABILITY SPECIFICATION</b> .....	<b>27</b>
8.1	RELIABILITY TESTS.....	27
<b>9</b>	<b>HANDLING PRECAUTIONS</b> .....	<b>28</b>

**REVISION RECORD**

Rev.	Date	Page	Chapt.	Comment	ECN no.
1.0	24-Mar-14			First Issue	
1.1	03-Apr-14	4	1	Added RoHS compliance to 2011/65/EU	
1.2	26-Jun-14	4,5 19 21-25	1,2.1 6 7.1.6	Weight added Updated Touch Screen Panel Specification Updated Inspection Specification	
1.3	17-Mar-15	6	2.2	Updated thickness of touch FPC stiffener Updated touch surface to glare (glossy)	

## 1 MAIN FEATURES

ITEM	CONTENTS
Screen Size	2.8" Diagonal
Display Format	240 x RGB x 320 Dots
N° of Colour	262K
Overall Dimensions	49 mm (H) x 69 mm (V) x 3.26 mm (D)
Active Area	43.2 mm (H) x 57.6 mm (V)
LCD Type	TFT
Mode	MVA Transmissive / Normally White
Viewing Direction	Full view
Interface	80-series CPU 8/9/16/18 bit selectable
Driver IC	ILI9341V or equivalent
Backlight Type	LED
Touch Panel Type	4-Wire Resistive
Operating Temperature	-20°C ~ +70°C
Storage Temperature	-30°C ~ +80°C
RoHS compliant	2011/65/EU
Weight	19 g

## 2 MECHANICAL SPECIFICATION

### 2.1 MECHANICAL CHARACTERISTICS

ITEM	CHARACTERISTIC	UNIT
Display Format	240 x RGB x 320 Dots	Dots
Overall Dimensions	49 mm (H) x 69 mm (V) x 3.26 mm (D)	mm
Viewing Area	43.2 (H) x 57.6 (V)	mm
Active Area	43.2 (H) x 57.6 (V)	mm
Dot Pitch	180 (H) x RGB x 180 (V)	μm
Weight	19	g

## 2.2 MECHANICAL DRAWING

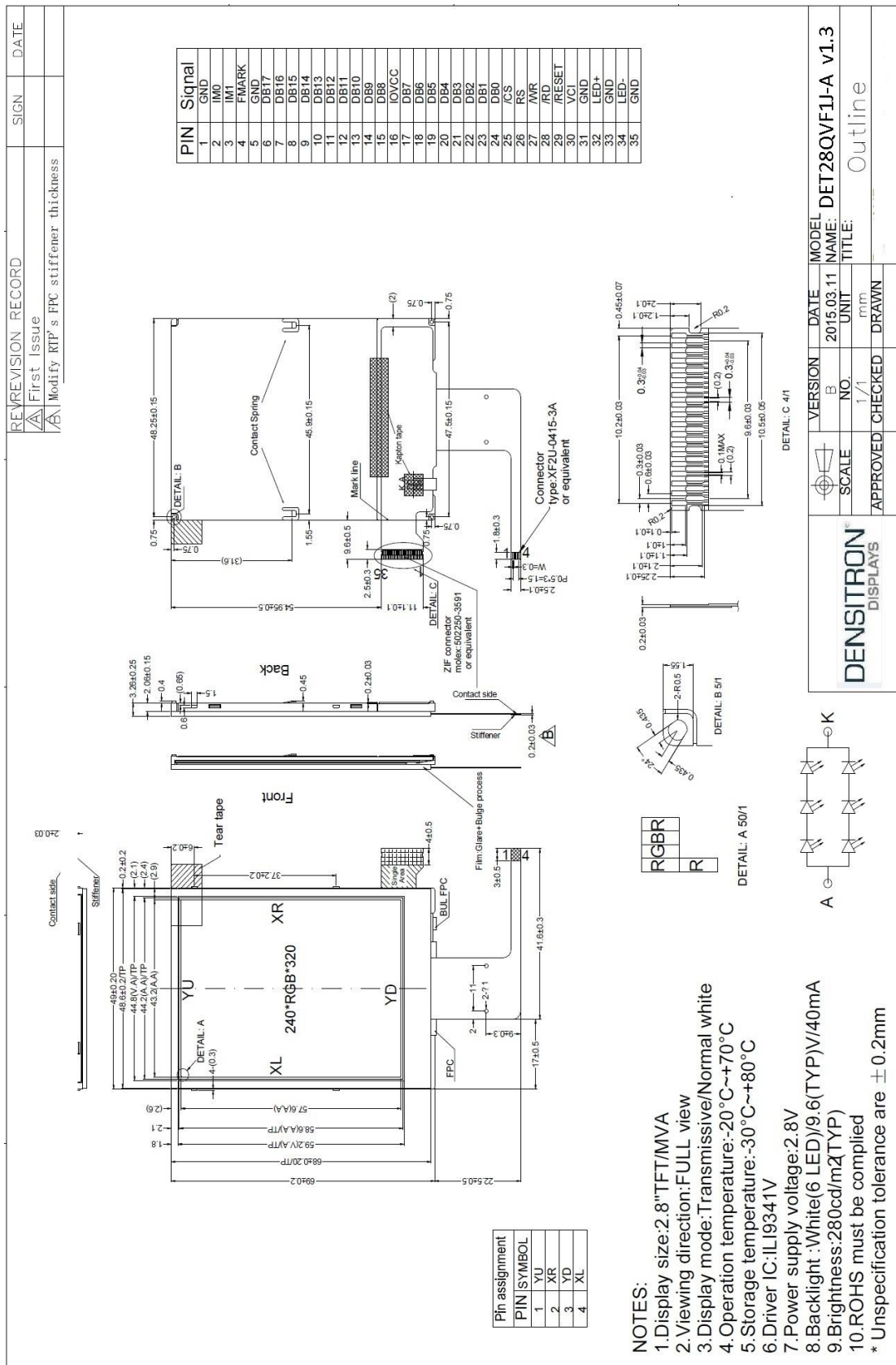

### 3 ELECTRICAL SPECIFICATION

#### 3.1 ABSOLUTE MAXIMUM RATINGS

Item	Symbol	Condition	Min	Max	Unit	Note
Power Supply Voltage	IOVCC, VCI	Ta=25°C	-0.3	4.6	V	
Operating Temperature	TOP		-20	70	°C	1
Storage Temperature	TST		-30	80	°C	1,2,3

Note 1. 90 % RH Max for Ta<50 °C, and 60% RH for Ta≥50°C.

Note 2. In case of below 0°C, the response time of liquid crystal (LC) becomes slower and the colour of panel becomes darker than normal one. Level of retardation depends on temperature, because of LC's characteristic.

Note 3. Only operation is guaranteed at operating temperature. Contrast, response time, another display quality are evaluated at +25°C.

#### 3.2 ELECTRICAL CHARACTERISTICS

Item	Symbol	Condition	Min	Typ	Max	Unit	Note
Supply Voltage	VCI		2.5	2.8	3.3	V	
	IOVCC		1.65	2.8	3.3	V	
Input Voltage for Logic	VIH		0.7xIOVCC	-	IOVCC	V	
	VIL		GND	-	0.3xIOVCC	V	
Output Voltage for Logic	VOH		0.8xIOVCC	-	IOVCC	V	
	VOL		GND	-	0.2xIOVCC	V	
Current Consumption	ICC		-	8.94		mA	1

Note 1: The specified power consumption is under the conditions of IOVCC=VCI=2.8V, FV=60Hz, whereas Power dissipation check pattern below is displayed.

Black pattern

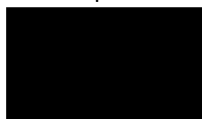

Active Area

### 3.3 INTERFACE PIN ASSIGNMENT

#### 3.3.1 LCM PIN ASSIGNMENT

Recommended connector: Molex 502250-3591

Pin No.	Symbol	Function				
1	GND	Ground				
2	IM0	IM1	IM0	Interface mode 80-series	DB Pin in use	
3	IM1				Register/Content	GRAM
					D[8:1]	D[17:10] D[8:1]
					D[17:10]	D[17:10]
					D[8:1]	D[17-0]
				D[17:10]	D[17:9]	
4	FMARK (TE)	Frame head pulse signal <i>(leave it Open if not used)</i>				
5	GND	Ground				
6	DB17	Data bus  <i>(connect unused pin(s) to VSS)</i>				
7	DB16					
8	DB15					
9	DB14					
10	DB13					
11	DB12					
12	DB11					
13	DB10					
14	DB9					
15	DB8					
16	IOVCC	Digital power supply				
17	DB7	Data bus  <i>(connect unused pin(s) to VSS)</i>				
18	DB6					
19	DB5					
20	DB4					
21	DB3					
22	DB2					
23	DB1					
24	DB0					
25	/CS (CSX)	Chip select signal active low				
26	RS (DCX)	Display data (RS=H) / Command selection (RS=L)				
27	/WR (WRX)	Write signal active low				
28	/RD (RDX)	Read signal active low				
29	/RESET (RESX)	Reset signal active low				
30	VCI	Analogue power supply				
31	GND	Ground				
32	LED+	LED power supply (+)				
33	GND	Ground				
34	LED-	LED power supply (-)				
35	GND	Ground				



### 3.4 BLOCK DIAGRAM

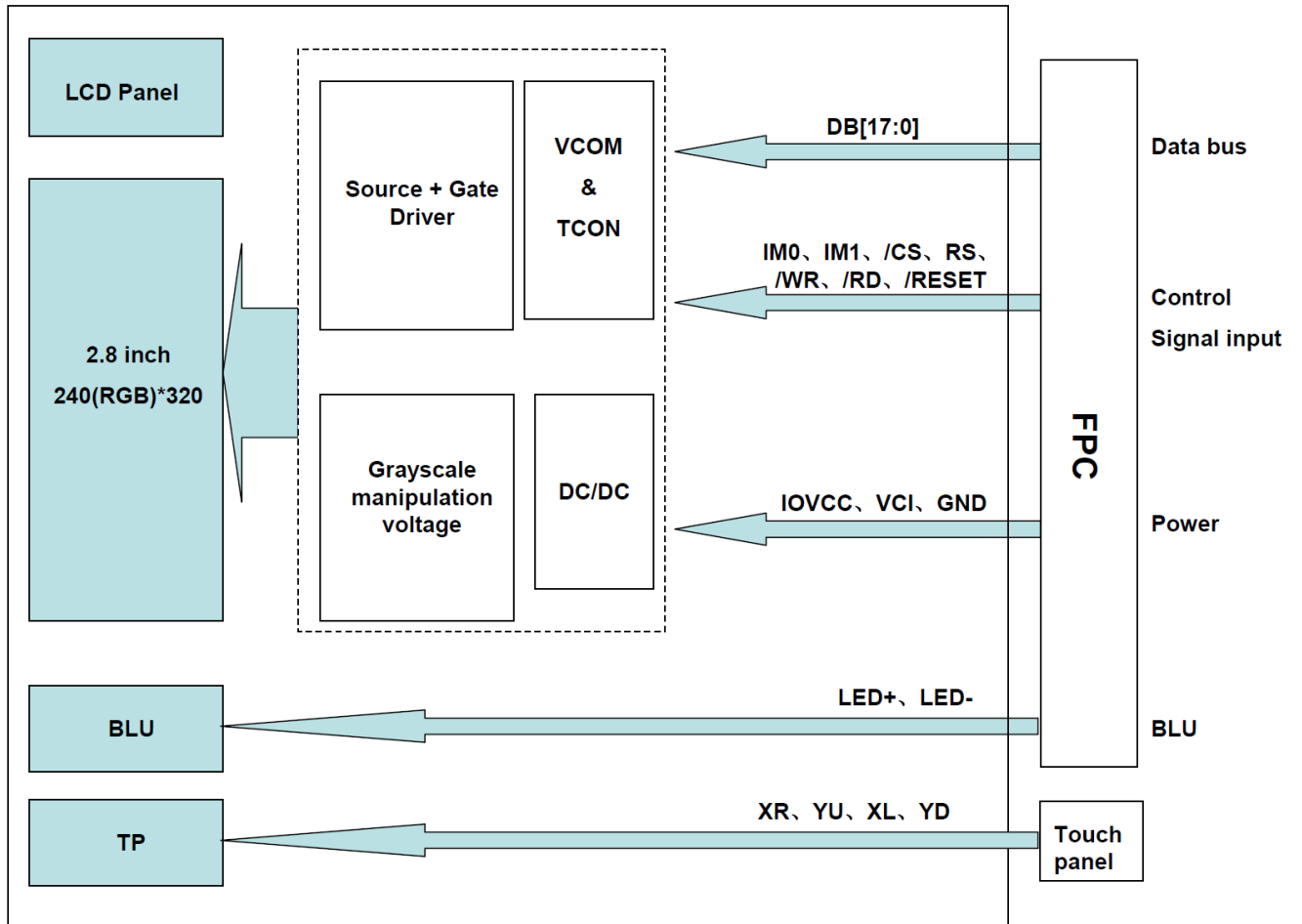

### 3.5 TIMING CHARACTERISTICS

Please refer to Ilitech IC ILI9341V datasheet for more information

#### 3.5.1 CPU 80-series Timing Characteristics (Interface II)

Item	Symbol	MIN	MAX	Unit	Remark
Address setup time	RS(DCX)	tast	0	-	Ns
Address hold time (Write/Read)		taht	0	-	ns
Chip select "H" pulse width	CS(CSX)	tchwh	0	-	ns
Chip select setup time (write)		tcs	15	-	ns
Chip select setup time (Read ID)		trcs	45	-	ns
Chip select setup time (Read FM)		trcsfm	355	-	ns
Chip select Wait time (Write/Read)		tcsf	10	-	ns
Write cycle		WR(WRX)	twc	66	-
Write Control pulse H duration	twrh		15	-	ns
Write Control pulse L duration	twrl		15	-	ns
Read cycle (FM)	RD(RDX (FM))	trcfm	450	-	ns
Read Control H duration (FM)		trdhfm	90	-	ns
Read Control L duration (FM)		trdlfm	355	-	ns
Read cycle (ID)	RD(RDX (ID))	trc	160	-	ns
Read Control H duration		trdh	90	-	ns
Read Control L duration		trdl	45	-	ns
Write data setup time	D[17:0], D[17:10] & D[8:1], D[17:10], D[17:9]	tdst	10	-	ns
Write data hold time		tdht	10	-	ns
Read access time		trat	-	40	ns
Read access time (FM)		tratfm	-	340	ns
Read output disable time		trod	20	80	ns

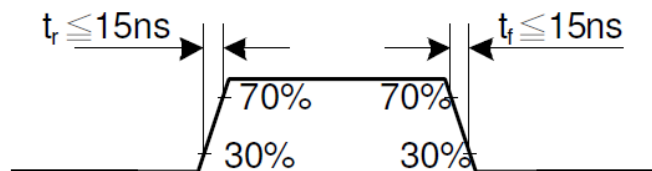

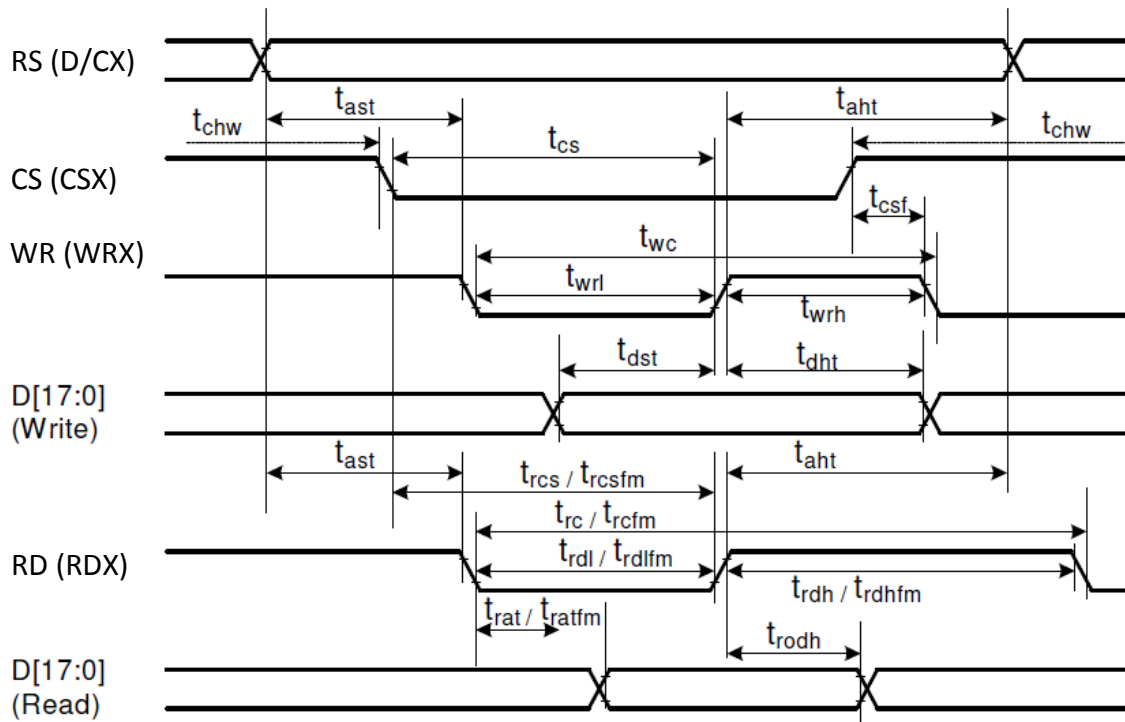

CS (CSX) timing:

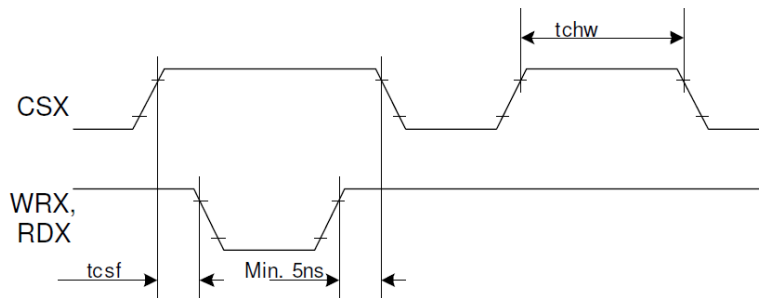

Write to read or read to write timings [WR (WRX), RD (RDX)]:

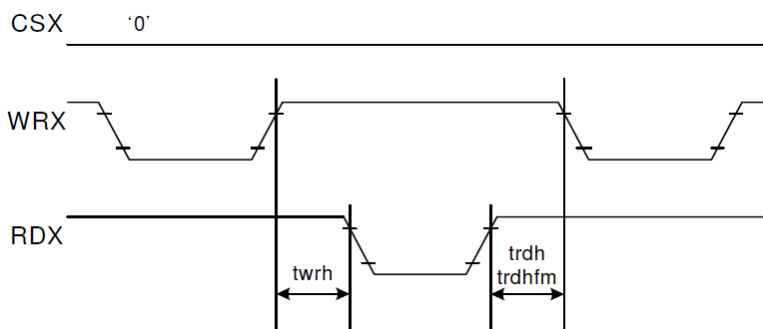

Note: Logic high and low levels are specified as 30% and 70% of IOVCC for Input signals.

### 3.6 COMMAND TABLE

Operational Code (HEX)	Function	Read/Write / Command	Number of Parameter	Parameters
00	No Operation	C	0	-
01	Software Reset	C	0	-
04	Read Display Identification Information	R	3	
09	Read Display Status	R	4	
0A	Read Display Power Mode	R	1	
0B	Read display MADCTL	R	1	
0C	Read Display Pixel Format	R	1	
0D	Read Display Image Mode	R	1	
0E	Read Display Signal Mode	R	1	
0F	Read Display Self Diagnostic Result	R	1	
10	Sleep In	C	0	-
11	Sleep Out	C	0	-
12	Partial Mode On	C	0	-
13	Normal Display Mode On	C	0	-
20	Display Inversion Off	C	0	-
21	Display Inversion On	C	0	-
26	Gamma Set	W	1	format: 1byte for curve selection
28	Display Off	C	0	-
29	Display On	C	0	-
2A	Column Address Set	W	4	format: 2 byte for leftmost Column counter 2 byte for rightmost Column counter
2B	Page Address Set	W	4	format: 2 byte for top line pointer 2 byte for bottom line pointer
2C	Memory Write	W	Any length	Successive video data stream Format in all colour modes
2E	Memory Read	R	Any length	Successive video data stream Format in all colour modes
30	Partial Area	W	4	format: 2 byte for top line pointer 2 byte for bottom line pointer

Operational Code (HEX)	Function	Read/Write / Command	Number of Parameter	Parameters
33	Vertical Scrolling Definition	W	6	format: 2 byte for fixed area top line pointer 2 byte for scrolling area height 2 byte for fixed area bottom line pointer
34	Tearing Effect Line Off	C	0	
35	Tearing Effect Line On	W	1	1 byte for Tearing Effect Line Mode selection
36	Memory Data Access Control	W	1	1 byte for memory scan direction
37	Vertical Scrolling Start Address	W	2	2 byte for line pointer
38	Idle Mode Off	C	0	-
39	Idle Mode On	C	0	-
3A	Interface Pixel Format	W	1	Refer to ILI9341V datasheet
DA	Read ID1	R	(1)	
DB	Read ID2	R	(1)	
DC	Read ID3	R	(1)	

### 3.7 POWER SEQUENCE

IOVCC and VCI can be applied in any order.

VCI and IOVCC can be powered down in any order.

During power off, if LCD is in the Sleep Out mode, VCI and IOVCC must be powered down minimum 120msec after RESET has been released.

During power off, if LCD is in the Sleep In mode, IOVCC or VCI can be powered down minimum 0msec after RESET has been released.

CS can be applied at any timing or can be permanently grounded. RESET has priority over CS.

Note 1: There will be no damage to the display module if the power sequences are not met.

Note 2: There will be no abnormal visible effects on the display panel during the Power On/Off Sequences.

Note 3: There will be no abnormal visible effects on the display between end of Power On Sequence and before receiving Sleep Out command. Also between receiving Sleep In command and Power Off Sequence.

Note 4: If RESET line is not held stable by host during Power On Sequence as defined in Sections 3.7.1 and 3.7.2, then it will be necessary to apply a Hardware Reset (RESET) after Host Power On Sequence is complete to ensure correct operation. Otherwise function is not guaranteed.

#### 3.7.1 Case 1 – RESET line is held High or Unstable by Host at Power ON

If RESET (RESX) line is held High or unstable by the host during Power On, then a Hardware Reset must be applied after both VCI and IOVCC have been applied – otherwise correct functionality is not guaranteed. There is no timing restriction upon this hardware reset.

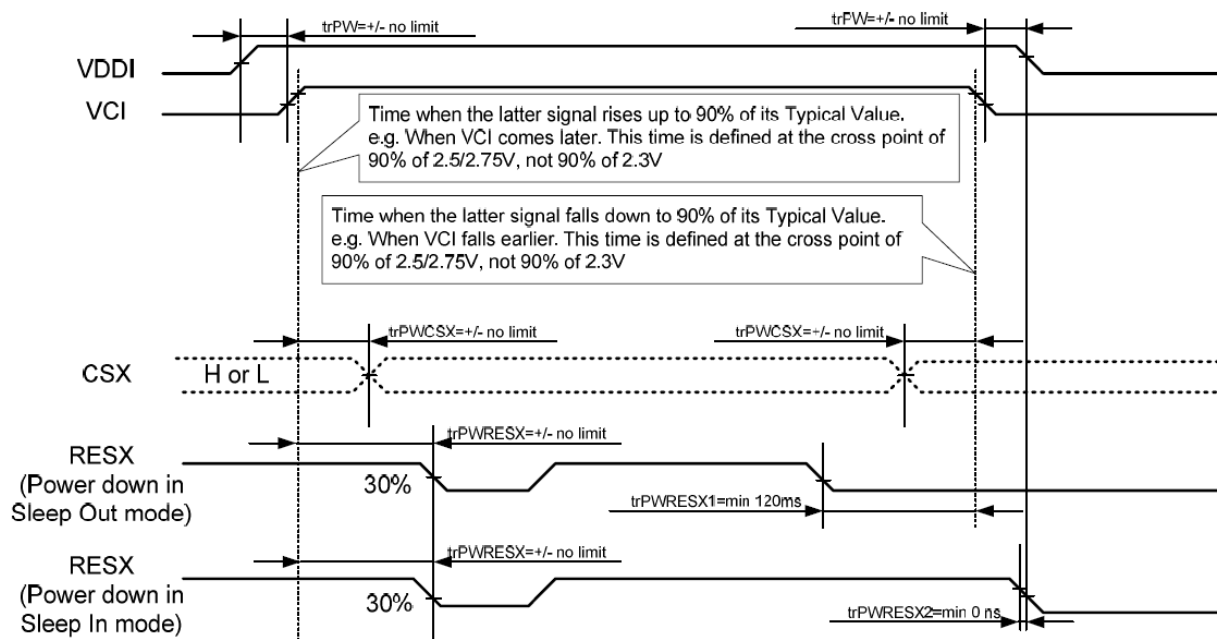

$trPWRESX1$  is applied to RESET (RESX) falling in the Sleep Out Mode

$trPWRESX2$  is applied to RESET (RESX) falling in the Sleep In Mode

### 3.7.2 Case 2 – RESET line is held Low by Host at Power ON

If RESET (RESX) line is held Low (and stable) by the host during Power On, then the RESET must be held low for minimum 10µsec after both VCI and IOVCC have been applied.

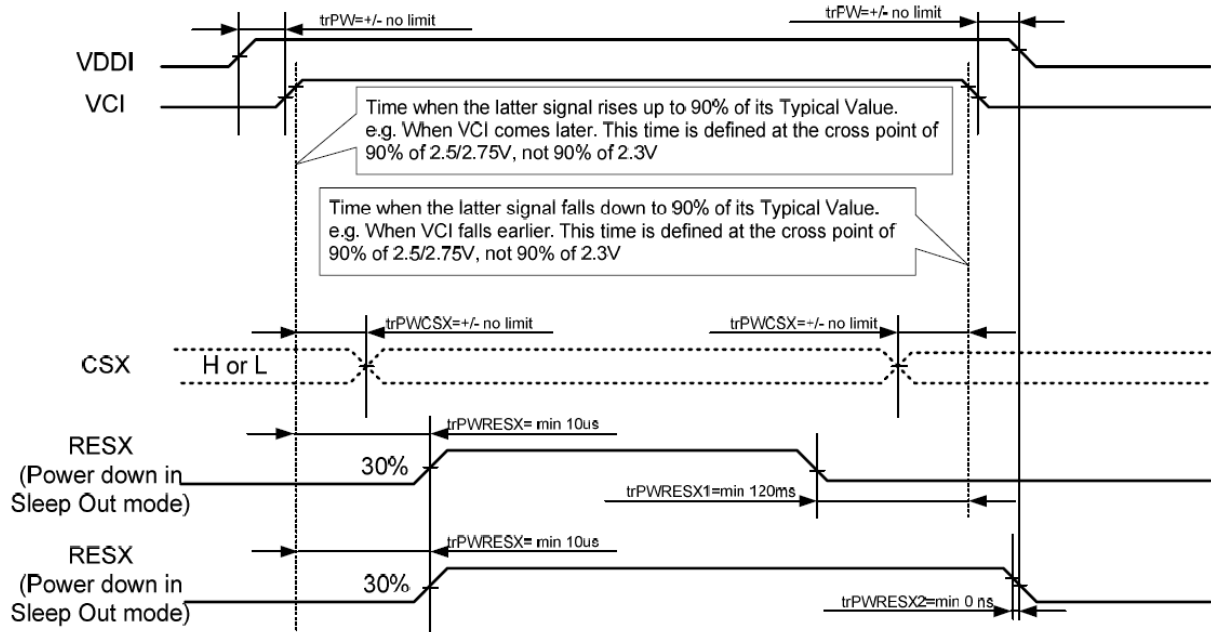

trPWRESX1 is applied to RESET (RESX) falling in the Sleep Out Mode

trPWRESX2 is applied to RESET (RESX) falling in the Sleep In Mode

### 3.7.3 Uncontrolled Power Off

The uncontrolled power off means a situation when e.g. there is removed a battery without the controlled power off sequence. There will not be any damages for the display module or the display module will not cause any damages for the host or lines of the interface. At an uncontrolled power off event, ILI9341V will force the display to blank and will not be any abnormal visible effects within 1 second on the display and remains blank until “Power On Sequence” activates.

For other settings and details please refer to ILI9341V data sheet.

## 4 OPTICAL SPECIFICATION

### 4.1 OPTICAL CHARACTERISTICS

Measuring instruments: LCD-5100, Eldim, Topcon BM-7  
 Driving condition: IOVCC = VCI = 2.8V, VSS = 0V  
 Backlight: IF=40mA  
 Measured temperature: Ta = 25° C

Item		Symbol	Condition	MIN	TYP	MAX	Unit	Note
Response Time		TR+TF	$\theta=\phi=0^\circ$ Normal Viewing Angle	-	25	30	ms	2
Contrast Ratio		CR		400	500	-		3
Viewing Angle	Left	$\theta_L$	CR $\geq$ 10	60	75	-	deg	4
	Right	$\theta_R$		60	75	-	deg	
	Up	$\phi_U$		60	75	-	deg	
	Down	$\phi_D$		60	75	-	deg	
Colour Chromaticity	Red	Rx	CR $\geq$ 10	0.599	0.649	0.699	-	5
		Ry		0.281	0.331	0.381	-	
	Green	Gx		0.274	0.324	0.374	-	
		Gy		0.586	0.636	0.686	-	
	Blue	Bx		0.092	0.142	0.192	-	
		By		0.043	0.093	0.143	-	
	White	Wx		0.257	0.307	0.357	-	
		Wy		0.291	0.341	0.391	-	
Centre Brightness				220	280	-	cd/m <sup>2</sup>	6
Brightness Distribution				70	-	-	%	7

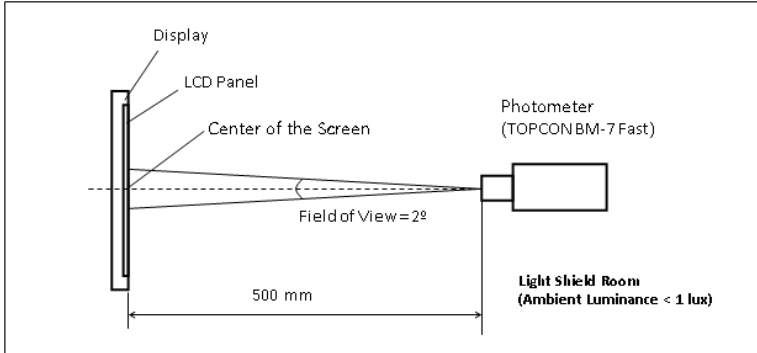
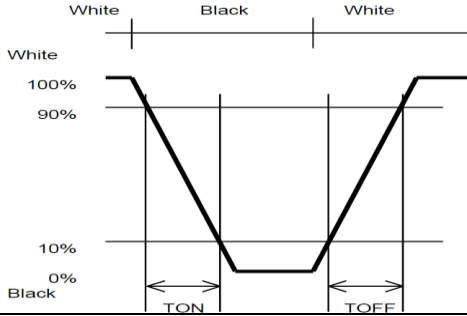
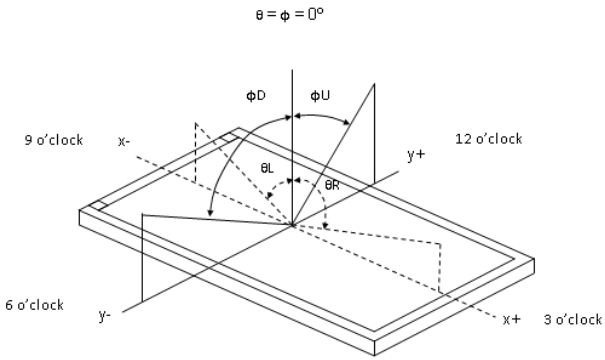

### 4.1.1 Test Method

Note	Item	Test method
1	Setup	<p>The display should be stabilised at a given temperature for 30 minutes to avoid abrupt temperature change during measuring. In order to stabilise the luminance, measurements should be executed after lighting the backlight for 30 minutes in a windless room.</p> 
2	Response time	<p>Measure output signal waveform by the luminance meter when raster of window pattern is changed from white to black and from black to white.</p> 
3	Contrast ratio	<p>Measure maximum brightness and minimum brightness at the centre of the screen by displaying raster or window pattern. Then calculate the ratio between these two values.</p> $\text{Contrast Ratio (CR)} = \frac{\text{Brightness of unselected position (white)}}{\text{Brightness of selected position (black)}}$
4	Viewing angle Horizontal $\theta$ Vertical $\phi$	<p>Move the luminance meter from right to left and up and down and determinate the angles where contrast ratio is 10</p> 
5	Colour chromaticity	Measure chromaticity coordinates x and y of CIE1931 colorimetric system
6	Centre brightness	Measure the brightness at the centre of the screen
7	Brightness distribution	<p>(Brightness distribution) = <math>100 \times B/A \%</math>  A: max. brightness of the 9 points  B: min. brightness of the 9 points</p>

## 5 BACKLIGHT SPECIFICATION

### 5.1 LED DRIVING CONDITIONS

Item	Symbol	Condition	Min	Typ	Max	Unit
Forward Current	IF	Ta=25 °C, VF=3.2V/LED	-	20*2	-	mA
Forward Voltage	VF	Ta= 25°C, IF= 20mA/LED	3.0*3	3.2*3	3.4*3	V
Power Consumption	PBL	Ta= 25°C, IL= 40mA	-	384	-	mW
Estimated Life t	LL	Ta= 25°C, IF= 40mA Note	(20000)	-	-	Hr
LED configuration	6 white LEDs (3 LEDs in one string and 2 groups in parallel)					

Note:

- The lifetime of the LED is defined as a period till the brightness of the LED decreases to the half of its initial value.
- This figure is given as a reference purpose only, and not a guarantee.
- This figure is estimated for an LED operating alone.  
The performance of an LED may differ when assembled as a monitor together with a TFT panel due to different environmental temperature.
- Estimated lifetime could vary on a different temperature and usually higher temperature could reduce the life significantly.

### 5.2 LED CIRCUIT

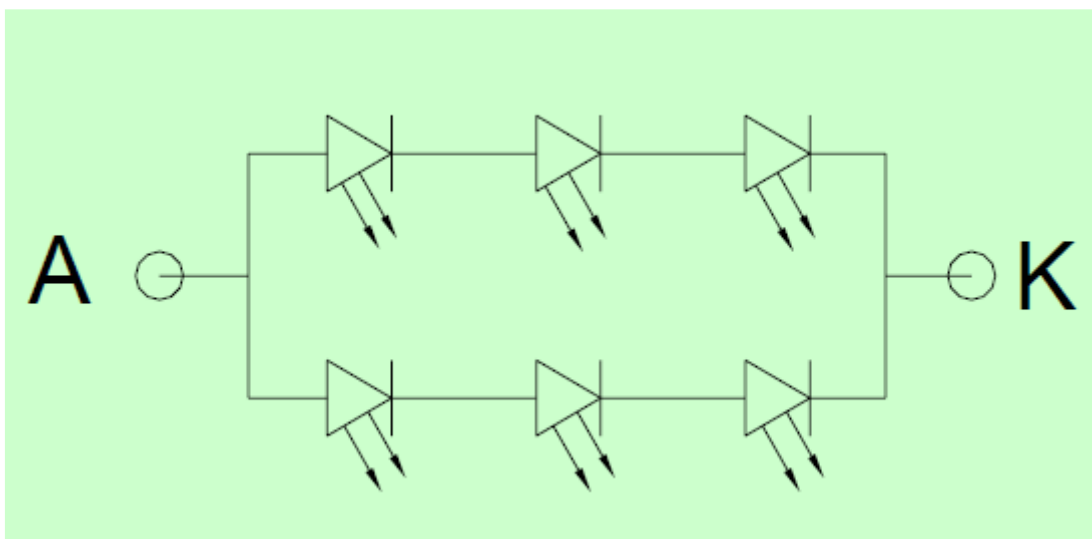

## 6 TOUCH PANEL CHARACTERISTICS

### 6.1 ELECTRICAL CHARACTERISTICS

Item	Min.	Typ.	Max.	Unit	Note
Linearity	-1.5	-	1.5	%	Analogue X and Y direction
Terminal Resistance	150	-	550	Ω	X(Film side)
	300	-	850	Ω	Y(Glass side)
Insulation Resistance	20	-	-	MΩ	DC<10V
Voltage	-	5	10	V	DC
Chattering	-	-	10	ms	
Transmittance	78	-	-	%	

Caution1: Do not operate with a thing except a polyacetal pen (tip R0.8mm or less) or a Finger, especially those with hard or sharp tips such as ball point pen or a mechanical pencil.

### 6.2 MECHANICAL CHARACTERISTICS

Item	Min.	Typ.	Max.	Unit	Note
Activation force	-	-	150	g	(1)
Durability-surface scratching	Write 20,000	-	-	Characters	(2)
Durability-surface pitting	1,000,000	-	-	touches	(3)
Surface hardness	3	-	-	H	

Note: (1) Stylus pen input: R0.8mm polyacetal pen or finger.

(2) Measurement for surface area.

- Force: 150-250gf
- Speed: 60mm/sec
- Stylus: R0.8mm polyacetal pen or finger.

(3) Pit 1,000,000 times on the film with a R3.75 silicon rubber.

- Force: 2.45N
- Speed: 3 times/sec

### 6.3 TOUCH PANEL PIN ASSIGNMENT

No.	Symbol	Function
1	YU	Touch Panel Terminal
2	XR	Touch Panel Terminal
3	YD	Touch Panel Terminal
4	XL	Touch Panel Terminal

Recommend connector: OMRON XF2U-0415-3A

## 7 QUALITY ASSURANCE SPECIFICATION

### 7.1 DELIVERY INSPECTION STANDARDS

#### 7.1.1 Inspection Conditions

Inspection distance: 30 cm ± 2 cm  
Viewing angle: ±45°

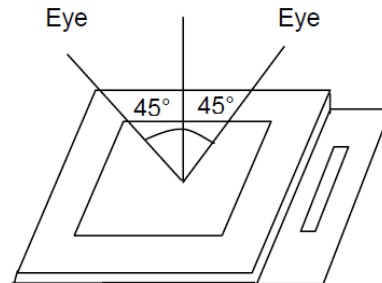

#### 7.1.2 Environmental Conditions

Ambient temperature: 23°C ±5°C  
Ambient humidity: 55±10% RH  
Ambient illumination: 1000~1500 lux

#### 7.1.3 Sampling Conditions

1. Lot size: quantity of shipment lot per model
2. Sampling method:

Sampling Plan		ANSI / ASQC Z1.4-1993
		Normal inspection, Single Sampling
AQL	Major Defect	0.65%
	Minor Defect	1.5%

#### 7.1.4 Definition of Area

A zone: active area  
B zone: viewing area

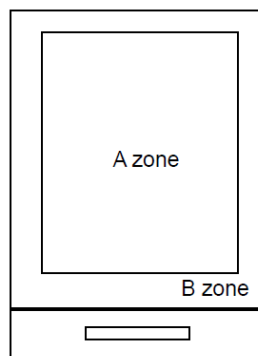

#### 7.1.5 Basic Principle

A set of sample to indicate the limit of acceptable quality level shall be discussed should a dispute occur.

### 7.1.6 Inspection Criteria

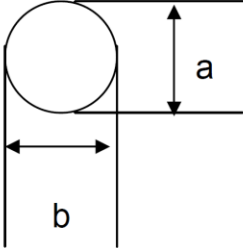
No.	Item	Criteria (Unit: mm)																			
01	Black / White spot Foreign material (Round type) Pinholes Stain Particles inside cell. (Minor defect)	 <p><math>\phi = (a + b) / 2</math> Distance between 2 defects should more than 3mm apart.</p>	<table border="1"> <thead> <tr> <th>Size</th> <th>Area</th> <th>Acc. Qty</th> </tr> </thead> <tbody> <tr> <td><math>\phi \leq 0.10</math></td> <td></td> <td>Ignore</td> </tr> <tr> <td><math>0.10 &lt; \phi \leq 0.15</math></td> <td></td> <td>2</td> </tr> <tr> <td><math>0.15 &lt; \phi \leq 0.25</math></td> <td></td> <td>1</td> </tr> <tr> <td><math>0.25 &lt; \phi</math></td> <td></td> <td>0</td> </tr> <tr> <td>Total</td> <td></td> <td>2 no include <math>\phi \leq 0.10</math></td> </tr> </tbody> </table>	Size	Area	Acc. Qty	$\phi \leq 0.10$		Ignore	$0.10 < \phi \leq 0.15$		2	$0.15 < \phi \leq 0.25$		1	$0.25 < \phi$		0	Total		2 no include $\phi \leq 0.10$
			Size	Area	Acc. Qty																
$\phi \leq 0.10$		Ignore																			
$0.10 < \phi \leq 0.15$		2																			
$0.15 < \phi \leq 0.25$		1																			
$0.25 < \phi$		0																			
Total		2 no include $\phi \leq 0.10$																			
02	Electrical Defect (Minor defect)	<table border="1"> <thead> <tr> <th></th> <th>Display Area</th> <th>Total</th> <th rowspan="3">Note1</th> </tr> </thead> <tbody> <tr> <td>Bright dot</td> <td>0</td> <td>0</td> </tr> <tr> <td>Dark dot</td> <td><math>N \leq 2</math></td> <td><math>N \leq 2</math></td> </tr> <tr> <td>Total dot</td> <td><math>N \leq 2</math></td> <td><math>N \leq 2</math></td> <td></td> </tr> <tr> <td>Mura</td> <td colspan="2">Not visible through 5% ND filters.</td> <td>Note 2</td> </tr> </tbody> </table> <p>Remark: 1. Bright dot caused by scratch and foreign object accords to item 1.</p>		Display Area	Total	Note1	Bright dot	0	0	Dark dot	$N \leq 2$	$N \leq 2$	Total dot	$N \leq 2$	$N \leq 2$		Mura	Not visible through 5% ND filters.		Note 2	
	Display Area	Total	Note1																		
Bright dot	0	0																			
Dark dot	$N \leq 2$	$N \leq 2$																			
Total dot	$N \leq 2$	$N \leq 2$																			
Mura	Not visible through 5% ND filters.		Note 2																		

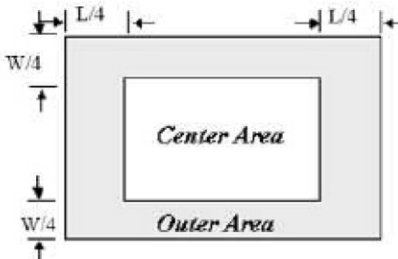
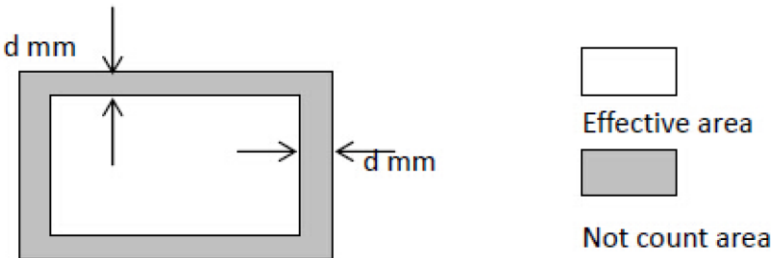
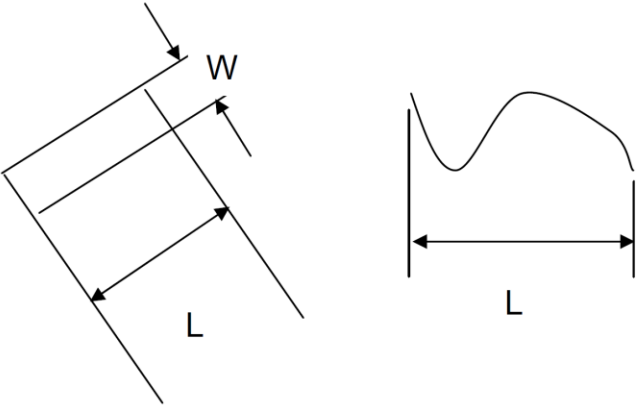
<p>03</p>	<p>Inactive Area (Minor defect)</p>	<p>Line Criteria: <math>L \leq 1\text{mm}</math>, <math>W \leq 0.1\text{mm}</math>, Dot Criteria: Please refer to Note 1,2&amp;3 <b>Note1:</b> Definition of Area</p>  <p><b>Note2:</b></p> <table border="1" data-bbox="523 698 1385 855"> <thead> <tr> <th>Size</th> <th>Inactive dot</th> <th>Center</th> <th>Outer</th> <th>Total</th> <th>Remark</th> </tr> </thead> <tbody> <tr> <td>All</td> <td><math>\Phi &lt; 0.2\text{mm}</math></td> <td colspan="4">Is not counted</td> </tr> <tr> <td>&lt;5"</td> <td><math>0.2 \leq \Phi \leq 0.3\text{mm}</math> <math>L \leq 1\text{mm}, W \leq 0.1\text{mm}</math></td> <td><math>N \leq 1</math></td> <td><math>N \leq 2</math></td> <td><math>N \leq 3</math></td> <td></td> </tr> </tbody> </table> <p><b>Note3:</b> Inactive area <math>D &lt; 0.2\text{mm}</math> is not counted without appearance observation. <b>Remark:</b> Effective area is from the POL cutting side to 0.5mm of inside. This is no count area. Other part is effective area. In no count area, any defect can ignore. In effective area, have to judge from above-mentioned specification.</p> 	Size	Inactive dot	Center	Outer	Total	Remark	All	$\Phi < 0.2\text{mm}$	Is not counted				<5"	$0.2 \leq \Phi \leq 0.3\text{mm}$ $L \leq 1\text{mm}, W \leq 0.1\text{mm}$	$N \leq 1$	$N \leq 2$	$N \leq 3$	
Size	Inactive dot	Center	Outer	Total	Remark															
All	$\Phi < 0.2\text{mm}$	Is not counted																		
<5"	$0.2 \leq \Phi \leq 0.3\text{mm}$ $L \leq 1\text{mm}, W \leq 0.1\text{mm}$	$N \leq 1$	$N \leq 2$	$N \leq 3$																
<p>04</p>	<p>Black and White line Scratch Foreign material (Line type) (Minor defect)</p>																			

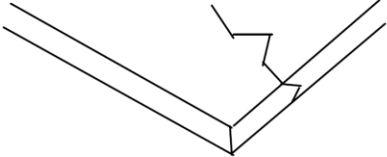
		<table border="1"> <thead> <tr> <th>Length</th> <th>Width</th> <th>Acc. Qty</th> </tr> </thead> <tbody> <tr> <td>/</td> <td><math>W \leq 0.03</math></td> <td>Ignore</td> </tr> <tr> <td><math>L \leq 2.5</math></td> <td><math>0.03 &lt; W \leq 0.05</math></td> <td>3</td> </tr> <tr> <td><math>L \leq 2.5</math></td> <td><math>0.05 &lt; W \leq 0.10</math></td> <td>2</td> </tr> <tr> <td>/</td> <td><math>0.1 &lt; W</math></td> <td>0</td> </tr> <tr> <td colspan="2">Total</td> <td>3</td> </tr> </tbody> </table> <p>Distance between 2 defects should more than 3mm apart. Scratches not viewable through the back of the display are acceptable.</p>	Length	Width	Acc. Qty	/	$W \leq 0.03$	Ignore	$L \leq 2.5$	$0.03 < W \leq 0.05$	3	$L \leq 2.5$	$0.05 < W \leq 0.10$	2	/	$0.1 < W$	0	Total		3
Length	Width	Acc. Qty																		
/	$W \leq 0.03$	Ignore																		
$L \leq 2.5$	$0.03 < W \leq 0.05$	3																		
$L \leq 2.5$	$0.05 < W \leq 0.10$	2																		
/	$0.1 < W$	0																		
Total		3																		
05	Glass Crack (Minor defect)	 <p>Crack is potential to enlarge, any type is not allowed.</p>																		

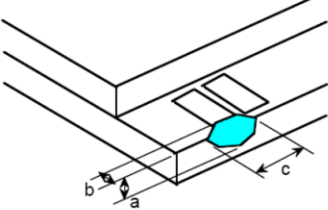
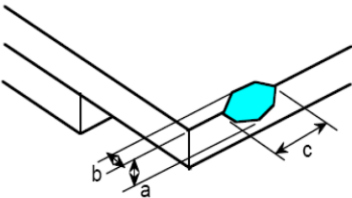
06	Glass Chipping Pad Area: (Minor defect)	 <table border="1"> <thead> <tr> <th>Length and Width</th> <th>Acc. Qty</th> </tr> </thead> <tbody> <tr> <td><math>c &gt; 3.0, b &lt; 1.0</math></td> <td>1</td> </tr> <tr> <td><math>c &lt; 3.0, b &lt; 1.0</math></td> <td>3</td> </tr> <tr> <td colspan="2"><math>a &lt; \text{Glass Thickness}</math></td> </tr> </tbody> </table>	Length and Width	Acc. Qty	$c > 3.0, b < 1.0$	1	$c < 3.0, b < 1.0$	3	$a < \text{Glass Thickness}$			
Length and Width	Acc. Qty											
$c > 3.0, b < 1.0$	1											
$c < 3.0, b < 1.0$	3											
$a < \text{Glass Thickness}$												
07	Glass Chipping Rear of Pad Area: (Minor defect)	 <table border="1"> <thead> <tr> <th>Length and Width</th> <th>Acc. Qty</th> </tr> </thead> <tbody> <tr> <td><math>c &gt; 3.0, b &lt; 1.0</math></td> <td>1</td> </tr> <tr> <td><math>c &lt; 3.0, b &lt; 1.0</math></td> <td>2</td> </tr> <tr> <td><math>c &lt; 3.0, b &lt; 0.5</math></td> <td>4</td> </tr> <tr> <td colspan="2"><math>a &lt; \text{Glass Thickness}</math></td> </tr> </tbody> </table>	Length and Width	Acc. Qty	$c > 3.0, b < 1.0$	1	$c < 3.0, b < 1.0$	2	$c < 3.0, b < 0.5$	4	$a < \text{Glass Thickness}$	
Length and Width	Acc. Qty											
$c > 3.0, b < 1.0$	1											
$c < 3.0, b < 1.0$	2											
$c < 3.0, b < 0.5$	4											
$a < \text{Glass Thickness}$												

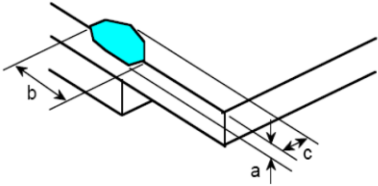
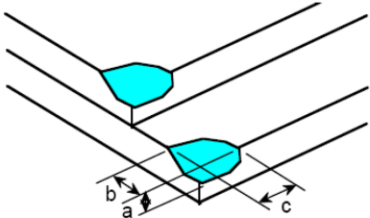
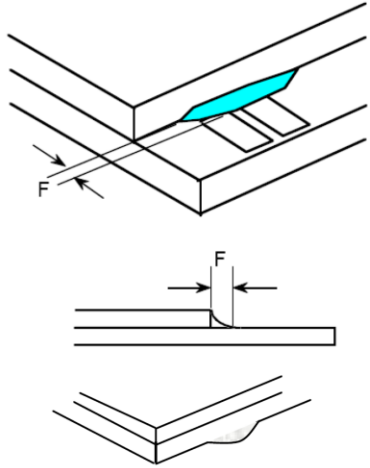
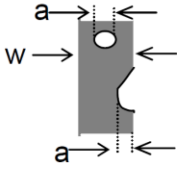
<p>08</p>	<p>Glass Chipping Except Pad Area: (Minor defect)</p> 	<table border="1" data-bbox="858 320 1286 517"> <thead> <tr> <th>Length and Width</th> <th>Acc. Qty</th> </tr> </thead> <tbody> <tr> <td><math>c &gt; 3.0, b &lt; 1.0</math></td> <td>1</td> </tr> <tr> <td><math>c &lt; 3.0, b &lt; 1.0</math></td> <td>2</td> </tr> <tr> <td><math>c &lt; 3.0, b &lt; 0.5</math></td> <td>4</td> </tr> <tr> <td colspan="2" style="text-align: center;"><math>a &lt; \text{Glass Thickness}</math></td> </tr> </tbody> </table>	Length and Width	Acc. Qty	$c > 3.0, b < 1.0$	1	$c < 3.0, b < 1.0$	2	$c < 3.0, b < 0.5$	4	$a < \text{Glass Thickness}$	
Length and Width	Acc. Qty											
$c > 3.0, b < 1.0$	1											
$c < 3.0, b < 1.0$	2											
$c < 3.0, b < 0.5$	4											
$a < \text{Glass Thickness}$												
<p>09</p>	<p>Glass Corner Chipping: (Minor defect)</p> 	<table border="1" data-bbox="858 660 1286 779"> <thead> <tr> <th>Length and Width</th> <th>Acc. Qty</th> </tr> </thead> <tbody> <tr> <td><math>c &lt; 3.0, b &lt; 3.0</math></td> <td>Ignore</td> </tr> <tr> <td colspan="2" style="text-align: center;"><math>a &lt; \text{Glass Thickness}</math></td> </tr> </tbody> </table>	Length and Width	Acc. Qty	$c < 3.0, b < 3.0$	Ignore	$a < \text{Glass Thickness}$					
Length and Width	Acc. Qty											
$c < 3.0, b < 3.0$	Ignore											
$a < \text{Glass Thickness}$												
<p>10</p>	<p>Glass Burr: (Minor defect)</p> 	<table border="1" data-bbox="858 1189 1286 1272"> <thead> <tr> <th>Length</th> <th>Acc. Qty</th> </tr> </thead> <tbody> <tr> <td><math>F &lt; 1.0</math></td> <td>Ignore</td> </tr> </tbody> </table> <p data-bbox="762 1196 826 1263">Glass don't</p> <p data-bbox="1321 1196 1385 1263">burr affect</p> <p data-bbox="762 1308 1129 1330">assemble and module dimension.</p>	Length	Acc. Qty	$F < 1.0$	Ignore						
Length	Acc. Qty											
$F < 1.0$	Ignore											
<p>11</p>	<p>FPC Defect: (Minor defect)</p> 	<p data-bbox="762 1644 1102 1715">11.1 Dent, pinhole width <math>a &lt; w/3</math>. (w: circuitry width.)</p> <p data-bbox="762 1733 1129 1756">11.2 Open circuit is unacceptable.</p> <p data-bbox="762 1778 1278 1800">11.3 No oxidation, contamination and distortion.</p>										



12	Bubble on Polarizer (Minor defect)	Diameter		Acc. Qty
		$\varphi \leq 0.20$		Ignore
		$0.20 < \varphi \leq 0.30$		4
		$0.30 < \varphi \leq 0.50$		1
		$0.50 < \varphi$		None
13	Dent on Polarizer (Minor defect)	Diameter		Acc. Qty
		$\varphi \leq 0.20$		Ignore
		$0.20 < \varphi \leq 0.30$		4
		$0.30 < \varphi \leq 0.50$		1
		$0.50 < \varphi$		None
14	Bezel	14.1 No rust, distortion on the Bezel. 14.2 No visible fingerprints, stains or other contamination.		
15	Touch Panel	D: Diameter W: width L: length 15.1 Spot: $D < 0.25$ is acceptable $0.25 \leq D \leq 0.4$ 2dots are acceptable and the distance between defects should more than 10 mm. $D > 0.4$ is unacceptable 15.2 Dent: $D > 0.40$ is unacceptable 15.3 Scratch: $W \leq 0.03$ , $L \leq 10$ is acceptable, $0.03 < W \leq 0.10$ , $L \leq 10$ is acceptable Distance between 2 defects should more than 10 mm. $W > 0.10$ is unacceptable.		
16	LCD Ripple	Touch the touch panel, cannot see the LCD ripple. Pen: R 0.8mm silicon rubber. Operation Force: 150g		
17	PCB	17.1 No distortion or contamination on PCB terminals. 17.2 All components on PCB must same as documented on the BOM/component layout. 17.3 Follow IPC-A-600F.		
18	Soldering	Follow IPC-A-610C standard		
19	Electrical Defect (Major defect)	The below defects must be rejected. 19.1 Missing vertical / horizontal segment, 19.2 Abnormal Display. 19.3 No function or no display. 19.4 Current exceeds product specifications.		

### **7.1.7 Classification of Defects**

Visual defects (except no or wrong label) are treated as minor defects, while electrical defects are treated as major defects.

Two minor defects are equal to one major defect in lot sampling inspection.

### **7.1.8 Identification / marking criteria**

Any unit with illegible / wrong / double or no marking / label shall be rejected.

## **7.2 DEALING WITH CUSTOMER COMPLAINTS**

---

### **7.2.1 Non-conforming analysis**

Purchaser should supply Densitron with detailed data of non-conforming sample.

After accepting it, Densitron should complete the analysis in two weeks from receiving the sample.

If the analysis cannot be completed on time, Densitron must inform the purchaser.

### **7.2.2 Handling of non-conforming displays**

If any non-conforming displays are found during customer acceptance inspection which Densitron is clearly responsible for, return them to Densitron.

Both Densitron and customer should analyse the reason and discuss the handling of non-conforming displays when the reason is not clear.

Equally, both sides should discuss and come to agreement for issues pertaining to modification of Densitron quality assurance standard.

## 8 RELIABILITY SPECIFICATION

### 8.1 RELIABILITY TESTS

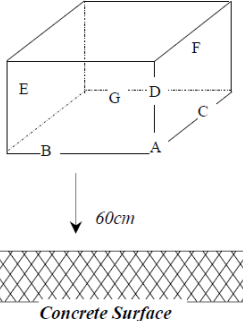
Test Item		Test Condition
Durability Test	High Temperature Storage	Ta= 80°C      96h
	Low Temperature Storage	Ta=-30°C      96h
	Temperature Cycle Storage	-30°C for 30 min, then 80°C for 30 min, 10 cycles
	High Temperature Operation	Tp= 70°C      96h
	Low Temperature Operation	Tp= -20°C      96h
	High Temperature & Humidity Operation	Tp= 60°C    RH= 90%    96h Non condensing
	Packaging vibration	Frequency range: 10Hz ~ 55Hz Amplitude of vibration: 1.5 mm Sweep time: 12 minutes X,Y,Z    2 hours in each direction
	Electrical Static Discharge	Air: ±4kV 150pF / 330Ω    5 times
		Contact: ±2kV 150pF / 330Ω    5 times
Drop Test	To be measured after dropping from 80cm high on concrete surface in packing state.  Corner dropping A corner: once  Edge dropping B, C, D edge: once  Face dropping E, F, G face: once	

Note: Ta=ambient temperature Tp= Panel temperature

Notes:

1. No dew condensation to be observed.
2. The function test shall be conducted after 4 hours storage at the normal temperature and humidity after removed from the test chamber.
3. No cosmetic or functional defects should be allowed.
4. Total current consumption should be less than twice the initial value.

## 9 HANDLING PRECAUTIONS

### **Safety**

If the LCD panel breaks, be careful not to get the liquid crystal fluid in your mouth or in your eyes. If the liquid crystal touches your skin or clothes, wash it off immediately using soap and plenty of water.

### **Mounting and Design**

Place a transparent plate (e.g. acrylic, polycarbonate or glass) on the display surface to protect the display from external pressure. Leave a small gap between the transparent plate and the display surface.

When assembling with a zebra connector, clean the surface of the pads with alcohol and keep the surrounding air very clean.

Design the system so that no input signal is given unless the power supply voltage is applied.

### **Caution during LCD cleaning**

Lightly wipe the display surface with a soft cloth soaked with Isopropyl alcohol, Ethyl alcohol or Trichlorotrifluoroethane.

Do not wipe the display surface with dry or hard materials that will damage the polariser surface.

Do not use aromatic solvents (toluene and xylene), or ketonic solvents (ketone and acetone).

### **Caution against static charge**

As the display uses C-MOS LSI drivers, connect any unused input terminal to VDD or VSS. Do not input any signals before power is turned on. Also, ground your body, work/assembly table and assembly equipment to protect against static electricity.

### **Packaging**

Displays use LCD elements, and must be treated as such. Avoid strong shock and drop from a height. To prevent displays from degradation, do not operate or store them exposed directly to sunshine or high temperature/humidity.

### **Caution during operation**

It is indispensable to drive the display within the specified voltage limit since excessive voltage shortens its life. Direct current causes an electrochemical reaction with remarkable deterioration of the display quality. Give careful consideration to prevent direct current during ON/OFF timing and during operation. Response time is extremely delayed at temperatures lower than the operating temperature range while, at high temperatures, displays become dark. However, this phenomenon is reversible and does not mean a malfunction or a display that has been permanently damaged. If the display area is pushed on hard during operation, some graphics will be abnormally displayed but returns to a normal condition after turning off the display once. Even a small amount of condensation on the contact pads (terminals) can cause an electro-chemical reaction which causes missing rows and columns. Give careful attention to avoid condensation.

### **Storage**

Store the display in a dark place where the temperature is 25°C ± 10°C and the humidity below 50%RH. Store the display in a clean environment, free from dust, organic solvents and corrosive gases.

Do not crash, shake or jolt the display (including accessories).

Product No.	DET28QVF1J-A	REV. 1.3
-------------	--------------	----------

Page	28 / 28
------	---------