

LIQUID CRYSTAL DISPLAY MODULE

Product Specification

PRODUCT NUMBER	84-0220-000T
-----------------------	---------------------

INTERNAL APPROVALS		
Product Manager	Engineering	Document Control
Date:	Date:	Date:

TABLE OF CONTENTS

1	GENERAL SPECIFICATIONS	4
2	FEATURES	4
3	MECHANICAL DRAWING	5
4	ABSOLUTE MAXIMUM RATINGS	5
5	ELECTRICAL CHARACTERISTICS	5
6	BLOCK DIAGRAM	6
7	ELECTRO-OPTICAL CHARACTERISTICS	7
8	CONNECTORS AND JUMPER SETTINGS	9
8.1	CONNECTORS	9
8.1.1	Power Supply Connector (TBD)	9
8.1.2	EEPROM Programming (TBD)	9
8.1.3	External PWM and Enable control (TBD)	9
8.1.4	External USB Touch Connector (TBD)	9
8.1.5	HDMI Connector (TBD)	10
8.1.6	External I2C Touch Connector (TBD)	10
8.1.7	Touch Pad Connector(TBD)	11
9	JUMPERS CONFIGURATION	11
9.1.1	Touch Interface Voltage Selection (TBD)	11
10	BASIC DISPLAY COLOR AND GRAY SCALE	12
11	RELIABILITY TEST	13
12	INCOMING INSPECTION STANDARDS	14
12.1	THE ENVIRONMENTAL CONDITION FOR INSPECTION	14
12.2	CLASSIFICATION OF DEFECTS AND AQL	14
12.3	INSPECTION PARAMETERS	15
13	HANDLING PRECAUTIONS	18

REVISION RECORD

Rev.	Date	Page	Par.	Comment	ECN no.
00	1/2/2015	--	--	New DCA Spec.	

1 GENERAL SPECIFICATIONS

ITEM	DESCRIPTION	UNIT
Module Outline Dimensions	143.5 (H) x 70.0 (V) x 13.65 (T) (Not including cable)	mm
Active Display Area	110.4 (H) x 62.1 (V)	mm
Pixel Configuration Format / Resolution	1280 (H) x 720 (V)	pixels
TFT Type	Transmissive / Normally Black	--
Backlight Type	LED	--
Weight	TBD	gram
Interface	HDMI	--
Luminance, White	390 cd/m ²	
Pixel Pitch	0.0.8625mm x 0.0.8625mm	mm
Color Depth	Hi FRC, 16.7M Colors	--
RoHS Compliant	Yes	--
Surface Treatment	Clear coating, 7H	--

2 FEATURES

- The display module is a 2U 5.0" diagonal 720P 16:9 supported TFT and can display 16.7M colors (Hi FRC).
- Glass-film-film PCT, with USB interfaces.
- HDMI interface
- Solidworks model available with Densitron NDA on file.

3 MECHANICAL DRAWING

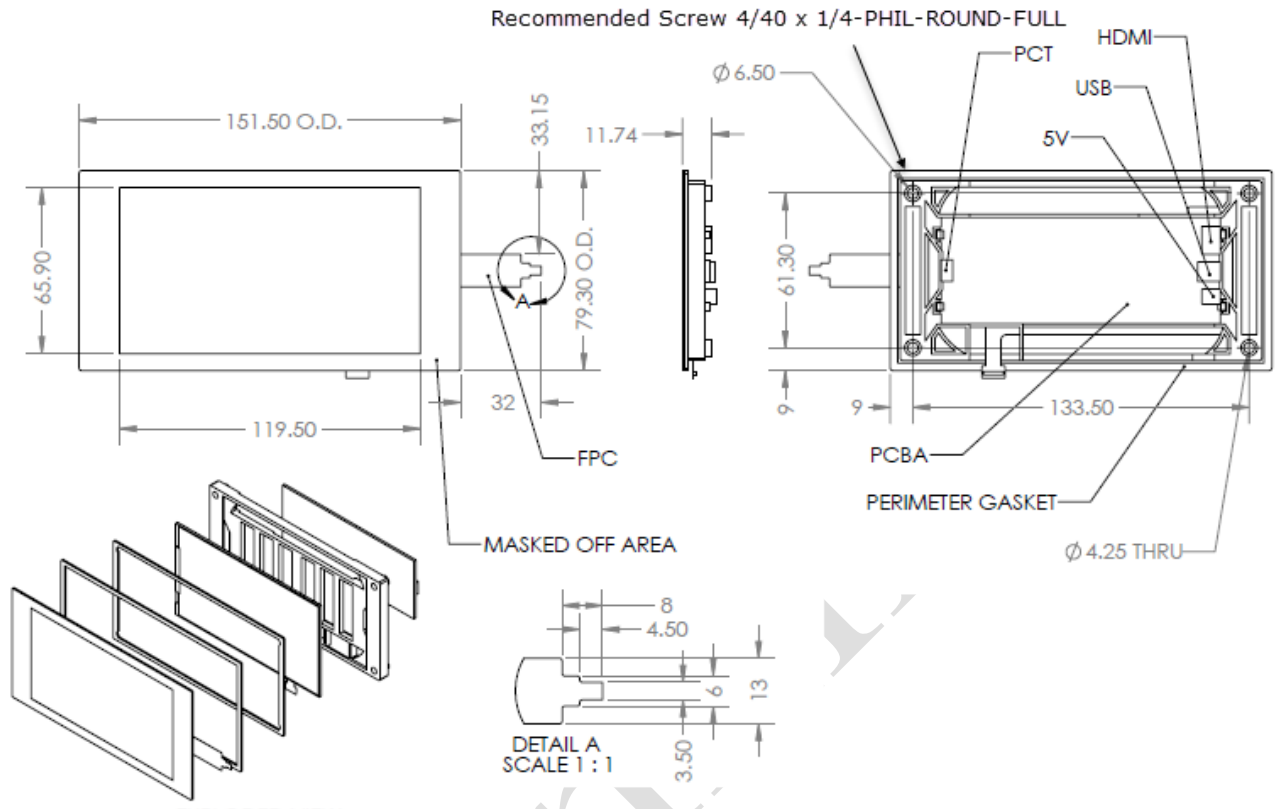

4 ABSOLUTE MAXIMUM RATINGS

The followings are maximum values which, if exceed, may cause faulty operation or damage to the unit. The operational and non-operational maximum voltage and current values are listed in Table 2.

< Table 2. LCD Module Electrical Specifications > [Ta = 25 ± 2 °C]

Parameter	Symbol	Min.	Max.	Unit	Remarks
Power Supply Voltage (LCD Module)	V _{DD}	-4.85	5.15	V	
Operating Temperature	T _{OP}	-20	+70	°C	
Storage Temperature	T _{ST}	-30	+80	°C	

5 ELECTRICAL CHARACTERISTICS

Product No.	84-0220-000T	REV.00
-------------	--------------	--------

Page	5 / 19
------	--------

6 BLOCK DIAGRAM

Preliminary

Product No.	84-0220-000T	REV.00
-------------	--------------	--------

Page	6 / 19
------	--------

7 ELECTRO-OPTICAL CHARACTERISTICS

Parameter		Symbol	Condition	Min.	Typ.	Max.	Unit	Remark
Viewing Angle range	Horizontal	Θ_3	CR > 10	75	80	-	Deg.	Note 2
		Θ_9		75	80	-	Deg.	
	Vertical	Θ_{12}		75	80	-	Deg.	
		Θ_6		75	80	-	Deg.	
Luminance Contrast ratio		CR	$\Theta = 0^\circ$	-	800	-		Note 1,4
Luminance of White	20mA/LED	Y_w	$\Theta = 0^\circ$	400	450	-	cd/m ²	Note 5
White Luminance uniformity				-	80	-		Note 6
White Chromaticity		W_x	$\Theta = 0^\circ$	Typ. -0.03	0.30	Typ. +0.03		
		W_y			0.32			
Reproduction of color	Red	R_x	$\Theta = 0^\circ$	Typ. -0.03	0.64	Typ. +0.03		
		R_y			0.33			
	Green	G_x			0.31			
		G_y			0.60			
	Blue	B_x			0.14			
		B_y			0.07			
Response Time (Rising + Falling)		T_{RT}	Ta= 25° C $\Theta = 0^\circ$	30	35	-	ms	Note 3

The optical characteristics should be measured in dark room, and after 5 minutes operation, the measurement begin.

Note1. Definition of Measure System

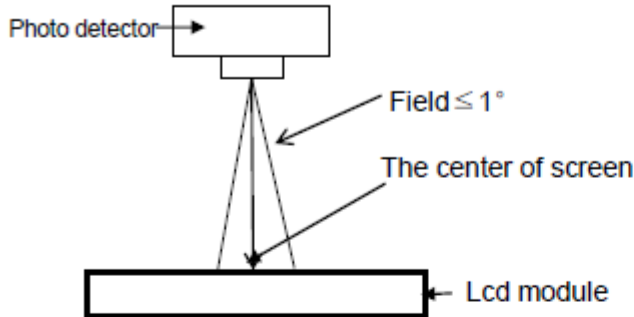

Note2. Definition of Angle Θ .

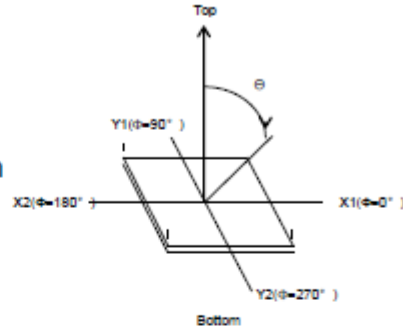

Note3. Definition of Response Time

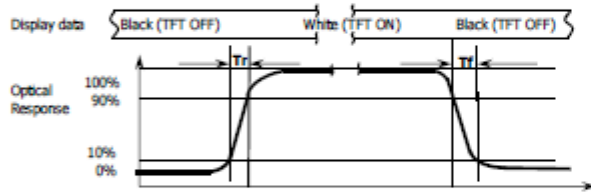

Note4. definition of contrast ratio

$$Cr = \frac{\text{Luminance of LCD White state}}{\text{Luminance of LCD Black state}}$$

Note 5. Measuring Point(9 Points) (WxH)

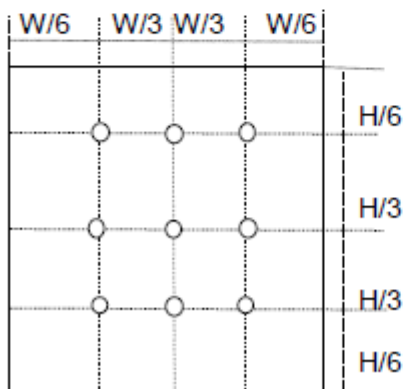

Rating is defined as the average brightness inside the viewing area

Note 6. definition of Uniformity

$$\text{Uniformity} = \frac{\text{min. Luminance of measured point}}{\text{max. Luminance of measured point}}$$

8 CONNECTORS AND JUMPER SETTINGS

8.1 Connectors

8.1.1 Power Supply Connector (TBD)

Pin	Name	Description
1	5V	5V 2A DC
2	GND	Ground

8.1.2 EEPROM Programming (TBD)

Pin	Name	Description
1	SCL	EEPROM SCL
2	TEST	EEPROM Test
3	SDA	EEPROM SDA
4	GND	Ground

8.1.3 External PWM and Enable control (TBD)

Pin	Name	Description
1	VCC	3.3V
2	PWM	PWM signal to controller backlight
3	GND	Ground
4	EN	Active high enable signal to on/off backlight

8.1.4 External USB Touch Connector (TBD)

Pin	Name	Description
1	5V	5V power
2	D-	Data differential pair minus
3	D+	Data differential pair plus
4	ID	On the Go Identification
5	GND	Ground

8.1.5 HDMI Connector (TBD)

Pin	Name	Description
1	Rx2+	Digital Input Channel2 True
2	GND	Ground
3	Rx2-	Digital Input Channel2 Complement
4	Rx1+	Digital Input Channel1 True
5	GND	No Connection
6	Rx1-	Digital Input Channel1 Complement
7	Rx0+	Digital Input Channel0 True
8	GND	Ground
9	Rx0-	Digital Input Channel0 Complement
10	RxC+	Digital Data Clock True
11	GND	Ground
12	RxC-	Digital Data Clock Complement
13-14	NC	No Connection
15-16	NC	No Connection
17	GND	Ground
18-19	NC	No Connection
20-21	GND	Ground
22-23	GND	Ground

8.1.6 External I2C Touch Connector (TBD)

Pin	Name	Description
1	VCC	3.3/5V 2A DC
2	TS_INT	GPIO Interrupt Signal
3	NC	No connection
4	TS_RESET	GPIO Reset Signal
5	NC	No connection
6	TS_SDA	I2C Data Signal
7	GND	Ground
8	TS_SCL	I2C Clock Signal

8.1.7 Touch Pad Connector(TBD)

Pin	Name	Description
1	VCC	5V/3.3V 2A DC
2	NC	No Connection
3	NC	No Connection
4	GND	Ground
5	TS_INT	GPIO Interrupt Signal
6	TS_RESET	GPIO Reset Signal
7	TS_SDA	I2C Data Signal
8	TS_SCL	I2C Clock Signal
9	GND	Ground

9 Jumpers Configuration

9.1.1 Touch Interface Voltage Selection (TBD)

This jumper used to set the Touch Panel operating voltage selection.

Pin	Description
1-2	USB 5V, for USB touch interface voltage
3-4	I2C 3.3V, for I2C touch interface voltage

Preliminary

10 BASIC DISPLAY COLOR AND GRAY SCALE

Color & Gray Scale		Input Data Signal																							
		Red Data						Green Data						Blue Data											
		R7	R6	R5	R4	R3	R2	R1	R0	G7	G6	G5	G4	G3	G2	G1	G0	B7	B6	B5	B4	B3	B2	B1	B0
Basic Colors	Black	0	0	0	0	0	0	0	0	0	0	0	0	0	0	0	0	0	0	0	0	0	0	0	0
	Blue	0	0	0	0	0	0	0	0	0	0	0	0	0	0	0	0	1	1	1	1	1	1	1	1
	Green	0	0	0	0	0	0	0	0	1	1	1	1	1	1	1	1	0	0	0	0	0	0	0	0
	Cyan	0	0	0	0	0	0	0	0	1	1	1	1	1	1	1	1	1	1	1	1	1	1	1	1
	Red	1	1	1	1	1	1	1	1	0	0	0	0	0	0	0	0	0	0	0	0	0	0	0	0
	Magenta	1	1	1	1	1	1	1	1	0	0	0	0	0	0	0	0	1	1	1	1	1	1	1	1
	Yellow	1	1	1	1	1	1	1	1	1	1	1	1	1	1	1	1	0	0	0	0	0	0	0	0
	White	1	1	1	1	1	1	1	1	1	1	1	1	1	1	1	1	1	1	1	1	1	1	1	1
Gray Scale of Red	Black	0	0	0	0	0	0	0	0	0	0	0	0	0	0	0	0	0	0	0	0	0	0	0	
	△	0	0	0	0	0	0	0	1	0	0	0	0	0	0	0	0	0	0	0	0	0	0	0	
	Darker	0	0	0	0	0	0	1	0	0	0	0	0	0	0	0	0	0	0	0	0	0	0	0	
	△																								
	▽																								
	Brighter	1	1	1	1	1	1	0	1	0	0	0	0	0	0	0	0	0	0	0	0	0	0	0	
	▽	1	1	1	1	1	1	1	0	0	0	0	0	0	0	0	0	0	0	0	0	0	0	0	
	Red	1	1	1	1	1	1	1	1	0	0	0	0	0	0	0	0	0	0	0	0	0	0	0	0
Gray Scale of Green	Black	0	0	0	0	0	0	0	0	0	0	0	0	0	0	0	0	0	0	0	0	0	0	0	
	△	0	0	0	0	0	0	0	0	0	0	0	0	0	0	0	1	0	0	0	0	0	0	0	
	Darker	0	0	0	0	0	0	0	0	0	0	0	0	0	0	1	0	0	0	0	0	0	0	0	
	△																								
	▽																								
	Brighter	0	0	0	0	0	0	0	0	1	1	1	1	1	1	0	1	0	0	0	0	0	0	0	
	▽	0	0	0	0	0	0	0	0	1	1	1	1	1	1	1	0	0	0	0	0	0	0	0	
	Green	0	0	0	0	0	0	0	0	1	1	1	1	1	1	1	1	0	0	0	0	0	0	0	
Gray Scale of Blue	Black	0	0	0	0	0	0	0	0	0	0	0	0	0	0	0	0	0	0	0	0	0	0	0	
	△	0	0	0	0	0	0	0	0	0	0	0	0	0	0	0	0	0	0	0	0	0	0	1	
	Darker	0	0	0	0	0	0	0	0	0	0	0	0	0	0	0	0	0	0	0	0	0	0	1	
	△																								
	▽																								
	Brighter	0	0	0	0	0	0	0	0	0	0	0	0	0	0	0	0	1	1	1	1	1	1	0	
	▽	0	0	0	0	0	0	0	0	0	0	0	0	0	0	0	0	1	1	1	1	1	1	0	
	Blue	0	0	0	0	0	0	0	0	0	0	0	0	0	0	0	0	1	1	1	1	1	1	1	
Gray Scale of White	Black	0	0	0	0	0	0	0	0	0	0	0	0	0	0	0	0	0	0	0	0	0	0	0	
	△	0	0	0	0	0	0	0	1	0	0	0	0	0	0	0	1	0	0	0	0	0	0	1	
	Darker	0	0	0	0	0	0	1	0	0	0	0	0	0	0	1	0	0	0	0	0	0	0	1	
	△																								
	▽																								
	Brighter	1	1	1	1	1	1	0	1	1	1	1	1	1	0	1	1	1	1	1	1	1	0	1	
	▽	1	1	1	1	1	1	1	0	1	1	1	1	1	1	0	1	1	1	1	1	1	1	0	
	White	1	1	1	1	1	1	1	1	1	1	1	1	1	1	1	1	1	1	1	1	1	1	1	

11 RELIABILITY TEST

No.	Test Item	Test Condition
1	High Temperature Storage	80 ± 2 °C / 240 hours
2	Low Temperature Storage	-30 ± 2 °C / 240 hours
3	High Temperature Operation	70 ± 2 °C / 240 hours
4	Low Temperature Operation	-20 ± 2 °C / 240 hours
5	Temperature Cycle	-30 ± 2 °C ~ 80 °C (0.5hr.) X 50 Cycles
6	Proof against Dampness	50 ± 5 °C X 90% RH / 120 hours; Pure Water Used (Resistance > 10 MΩ)
7	Vibration Test	Frequency: 10 Hz ~ 55 Hz ~ 10 Hz Amplitude: 1.5 mm X,Y & Z directions for a total of 3 hours
8	Dropping Test	Dropped to the ground from 1 m height, one time and test ed on all sides of the carton when packed.
9	ESD Test	-Panel Surface/Top Case : 150pF, 150Ω (Air: ±15kV, Contact: ±8kV) -FPC input terminal: 100pF ±200V 0Ω
Inspection after Test		The sample is tested for the following defects after 2 ~ 4 hours of storage at room temperature: <ul style="list-style-type: none"> 1. Air bubbles in the TFT 2. Leaking Seal 3. No Display 4. Missing Segments 5. Glass Cracks 6. Idd current is higher than twice the initial value
Remarks: <ul style="list-style-type: none"> 1. The test samples are applicable to only one test group. 2. Sample size for each test group is 5 ~ 10 pieces. 3. In case of a malfunction caused by ESD test, if it recovers to the normal state after resetting, it would be judged as a good part. 4. Please use automatic switch menu (or roll menu) in test mode. 		

12 INCOMING INSPECTION STANDARDS

12.1 THE ENVIRONMENTAL CONDITION FOR INSPECTION

The environmental condition and visual inspection shall be conducted as below.

- (1) Ambient temperature: 25 ± 5 °C
- (2) Humidity: 60 ± 5 % RH
- (3) Viewing distance: 35 ~ 40 cm approx.
- (4) Viewing angle: Normal to the TFT panel as shown below
- (5) Ambient Illumination: 300 ~ 500 Lux. for external appearance inspection.

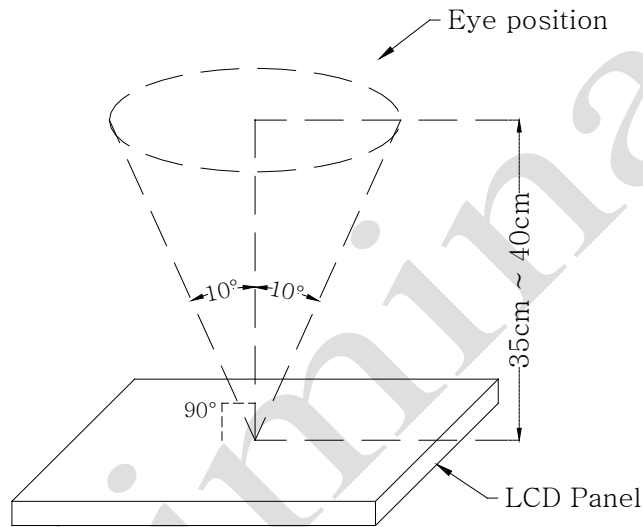

12.2 CLASSIFICATION OF DEFECTS AND AQL

Class of defects	AQL	Definition
Major	1.0%	It is a defect that is likely to result in failure or to reduce materially the usability of the intended function.
Minor	1.5%	It is a defect that will not result in a functioning problem with deviation classified.

Note: Sampling plan according to GB / T2828.1-2003 / ISO 2859-1:1999 and ANSI/ASQC Z1.4-1993, Normal level 2.

12.3 INSPECTION PARAMETERS

Item		Specification / Description			Note	
Display	Function	No display			-	
		Malfunction			-	
Operating	Contrast ratio	Out of spec.			-	
	Line defect	No obvious Vertical and Horizontal line defects for the bright, dark and colored.			-	
	Point defect (red, green, blue, black, white)	Item	Acceptable number			1, 4, 5, 6
			A	B	Total	
		Bright dot	$N \leq 1$	$N \leq 2$	$N \leq 4$	
		Black / dark dot	$N \leq 2$	$N \leq 3$		
		Total dots	$N \leq 3$	$N \leq 5$		
		Two adjacent dots	Not allowed			
Three or more adjacent dots	Not allowed					
External Inspection (Non-operating)	Scratch on the Polarizer	L (mm)	W (mm)	Acceptable number	2	
		$L \leq 2.5$	$W \leq 0.1$	4		
		$L > 2.5$	$W > 0.1$	0		
	Dent or bubble on the polarizer	Dimension (mm)		Acceptable number	3	
		$D \leq 0.5$		4		
		$D \leq 0.15$		Disregard		
	Foreign material on the polarizer	Dimension (mm)		Acceptable number	3	
		$D \leq 0.5$		4		
		$D \leq 0.15$		Disregard		

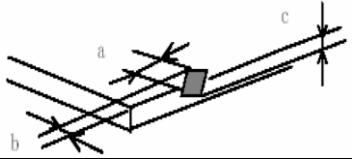
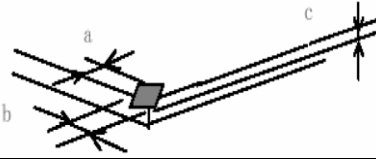
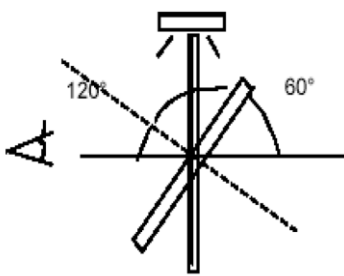
Item		Specification / Description			Note
Touch Panel (If Present)	Scratch	L (mm)	W (mm)	Acceptable number	2
		L ≤ 10	W < 0.05	Disregard	
			0.05 ≤ W < 0.1	N ≤ 4	
			W ≥ 0.1	0	
	Foreign materials (Linear shape)	L ≤ 10	W < 0.05	Disregard	2
			0.05 ≤ W < 0.1	N ≤ 3	
			W ≥ 0.1	0	
	Foreign materials (Circular shape)	Dimension (mm)		Acceptable number	3
		D ≤ 0.25		Disregard	
		0.25 < D ≤ 0.5		N ≤ 6	
D > 0.5		0			
Glass chips			a ≤ 5mm b ≤ 3mm c ≤ t (t: Glass Thickness)	7	
			a ≤ 3mm b ≤ 3mm c ≤ t (t: Glass thickness)		
Newton's rings	(In case of doubtful situations only) Observe at 60° from the product surface for a while under a Fluorescent lamp. (3-Wavelength lamp)			If Average Diameter ≤ (1/3) Touch Panel Area, Disregard.	7

Note 1: The definition of dot defect: The dot defect was judged after repair and the size of a defective dot with size over 1/2 of one standard dot is regarded as one defective dot.

Note 2:

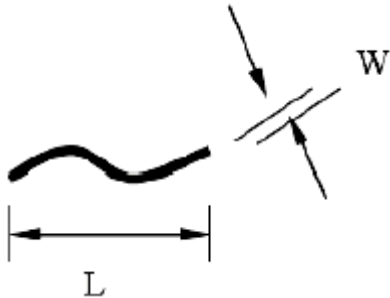

Note 3: Diameter - $D = (a + b) / 2$



Note 4: A bright dot is defined with 6% transmission ND filter as shown below:

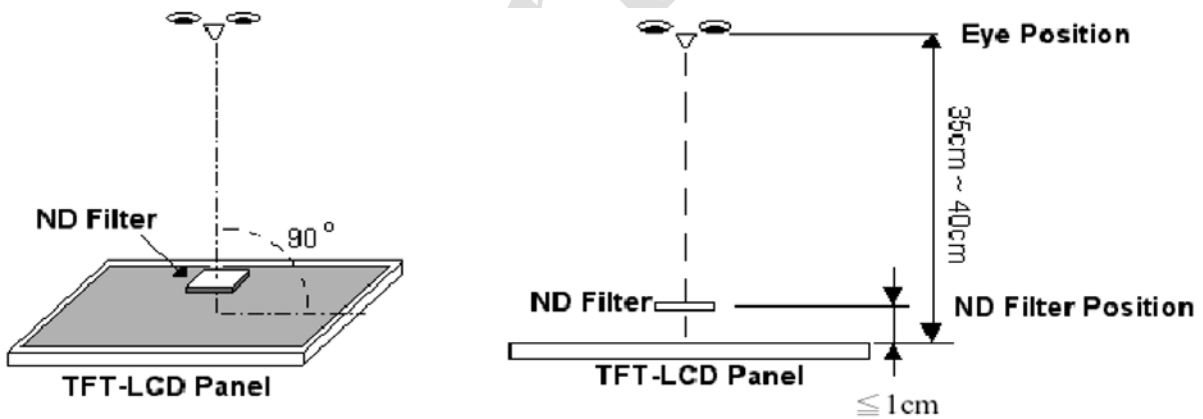

Note 5: Adjacent Dots:



Note 6:



13 HANDLING PRECAUTIONS

Safety

If the TFT panel breaks, be careful not to get the liquid crystal fluid in your mouth or in your eyes. If the liquid crystal touches your skin or clothes, wash it off immediately using soap and plenty of water.

Mounting and Design

Place a transparent plate (e.g. acrylic, polycarbonate or glass) on the display surface to protect the display from external pressure. Leave a small gap between the transparent plate and the display surface. When assembling with a zebra connector, clean the surface of the pads with alcohol and keep the surrounding air very clean. Design the system so that no input signal is given unless the power supply voltage is applied.

Caution during TFT cleaning

Lightly wipe the display surface with a soft cloth soaked with Isopropyl alcohol, Ethyl alcohol or Trichlorotrifluoroethane. Do not wipe the display surface with dry or hard materials that will damage the polarizer surface. Do not use aromatic solvents (toluene and xylene), or ketonic solvents (ketone and acetone).

Caution against static charge

As the display uses C-MOS LSI drivers, connect any unused input terminals to VDD or VSS. Do not input any signals before power is turned on. Also, ground your body, work / assembly table and assembly equipment to protect against static electricity.

Packaging

Displays use TFT elements, and must be treated as such. Avoid strong shock and drop from a height. To prevent displays from degradation, do not operate or store them exposed directly to sunlight or high temperature / humidity.

Caution during operation

It is indispensable to drive the display within the specified voltage limit since excessive voltage shortens its life. Direct current causes an electrochemical reaction with remarkable deterioration of the display quality. Give careful consideration to prevent direct current during ON/OFF timing and during operation. Response time is extremely delayed at temperatures lower than the operating temperature range while, at high temperatures, displays become dark. However, this phenomenon is reversible and does not mean a malfunction or a display that has been permanently damaged. If the display area is pushed on hard during operation, some graphics will be abnormally displayed but returns to a normal condition after turning off the

Product No.	84-0220-000T	REV.00
-------------	--------------	--------

Page	18 / 19
------	---------

display once. Even a small amount of condensation on the contact pads (terminals) can cause an electro-chemical reaction which causes missing rows and columns. Give careful attention to avoid condensation.

Storage

Store the display in a dark place where the temperature is $25^{\circ}\text{C} \pm 10^{\circ}\text{C}$ and the humidity below 50% RH. Store the display in a clean environment, free from dust, organic solvents and corrosive gases. Do not crash, shake or jolt the display (including accessories).

Preliminary