

ITO PROJECTIVE CAPACITIVE TOUCH PANEL

Product Specification

PRODUCT NUMBER	DTS424-0700-1FX-000
---------------------------	----------------------------

INTERNAL APPROVALS		
Product Manager	Engineering	Document Control

TABLE OF CONTENTS

1 MAIN FEATURES3
 2 MECHANICAL DRAWING4
 3 ENVIRONMENTAL CONDITIONS.....5
 4 PIN ASSIGNMENT5
 5 ELECTRIC CHARACTERISTICS6
 6 OPTICAL CHARACTERISTICS8
 7 FUNCTIONAL BLOCKS9
 8 I2C10
 9 RELIABILITY TEST12
 10 DURABILITY.....12
 11 QUALITY ASSURANCE SPECIFICATION13

REVISION RECORD

Rev.	Date	Page	Par.	Comment	ECN no.
A	07/09/12	--	--	New DCA Specification	E4678

1 MAIN FEATURES

ITEM	CONTENTS	UNIT
Input Mode	Finger / Gloves	--
Structure	Glass on Film Film	--
TP OL	174.40 (W) x 113.40 (H)	mm
Sensor Area(Active Area)	155.40 (W) x 93.24 (H)	mm
IC/Interface	FT5406 /I2C	--
Touch Panel Resolution	100 dots per inch	Pixel
Total Thickness	1.525 ±0.10 (D)	mm

2 MECHANICAL DRAWING

Rear View

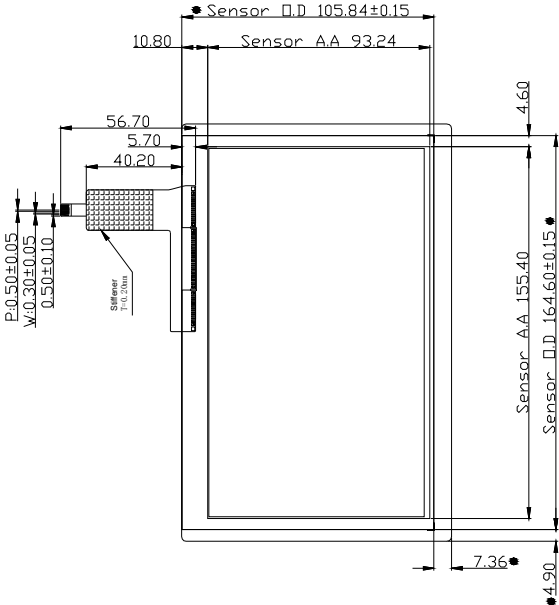

Top View

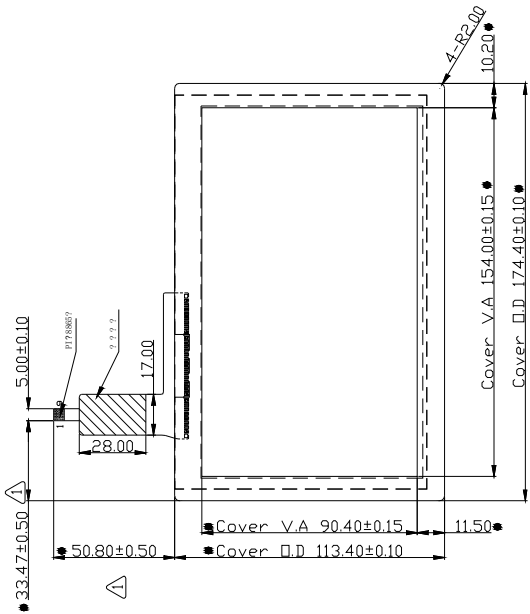

PIN	NAME
1	VDD3.3V
2	NC
3	NC
4	GND
5	INT
6	RST
7	SDA
8	SCL
9	GND

Product No.	DTS424-0700-1FX-000	REV. A
-------------	---------------------	--------

Page	4 / 14
------	--------

3 ENVIRONMENTAL CONDITIONS

Item	Specifications	
	Temperature	Humidity (Non Condensing)
Operation	-20 °C ~ +70 °C	10%RH ~ 90%RH
Storage	-20 °C ~ +70 °C	10%RH ~ 90%RH

4 PIN ASSIGNMENT

Pin No.	Symbol	I/O	Description
1	VDD 3.3V	--	Power
2	NC	--	No Connection
3	NC	--	No Connection
4	GND	--	Ground
5	INT	--	Active low
6	RST	--	RST
7	SDA	--	I2C Data
8	SCL	--	I2C Clock
9	GND	--	Ground

Recommended mating connector:
Molex 0512810994
Molex 0527450997

5 ELECTRIC CHARACTERISTICS

5.1 Absolute Maximum Ratings

Item	Symbol	Unit	Value	Note
Power Supply Voltage 1	VDDA - VSSA	V	-0.3 ~ +3.6	1, 2
Power Supply Voltage 2	VDD3 - VSS	V	-0.3 ~ +3.6	1, 3
I/O Power Supply Voltage	Vt	V	-0.3 ~ IOVCC + 0.3	1,4
Operating Temperature	Topr	°C	-40 ~ +85	1
Storage Temperature	Tstg	°C	-55 ~ +110	1

Notes

- 1、 If used beyond the absolute maximum ratings, FT5x06 may be permanently damaged. It is strongly recommended that the device be used within the electrical characteristics in normal operations. If exposed to the condition not within the electrical characteristics, it may affect the reliability of the device.
- 2、 Make sure VDDA(high) ≥ VSSA (low)
- 3、 Make sure VDD (high) ≥ VSS (low)
- 4、 IOVCC is set to VDD3 or VDDD by software configuration.

5.2 DC Characteristics (VDDA=VDD3=2.8~3.3V, Ta=-40~85°C)

Item	Symbol	Unit	Test Condition	Min.	Typ.	Max.	Note
Input high-level voltage	VIH	V		0.7 x IOVCC	--	IOVCC	
Input low-level voltage	VIL	V		-0.3	--	0.3 x IOVCC	
Output high-level voltage	VOH	V	IOH=-0.1mA	0.7 x IOVCC	--	--	
Output low-level voltage	VOL	V	IOH=0.1mA	--	--	0.3 x IOVCC	
I/O leakage current	ILI	μA	Vin=0~VDDA	-1	--	1	
Current consumption (Normal operation mode)	Iopr	mA	VDDA=VDD3 = 2.8V Ta=25°C MCLK=24MHz	--	6	--	
Current consumption (Monitor mode)	Imon	mA	VDDA=VDD3 = 2.8V Ta=25°C MCLK=24MHz	--	4	--	
Current consumption (Sleep mode)	Islp	mA	VDDA=VDD3 = 2.8V Ta=25°C MCLK=24MHz	--	0.03	--	
Step-up output voltage	VDD5	V	VDDA=VDD3= 2.8V	5	5.25	5.6	
Power Supply voltage	VDDA VDD3	V		2.8	--	3.6	

5.3 AC Characteristics

AC Characteristics of Oscillators

Item	Symbol	Unit	Test Condition	Min.	Typ.	Max.	Note
OSC clock 1	fosc1	MHz	VDD3 = 2.8V Ta=25°C	43	48	52	
OSC clock 2	fosc2	KHz	VDD3 = 2.8V Ta=25°C	29	32	36	

AC Characteristics of TX & RX

Item	Symbol	Unit	Test Condition	Min	Typ	Max	Note
TX acceptable clock	ftx	KHz		100	150	270	
TX output rise time	Ttxr	nS		--	20	--	
TX output fall time	Ttxf	nS		--	20	--	
RX input voltage	Trxi	V		1.2	--	1.6	

6 OPTICAL CHARACTERISTICS

There are 2 optical test specifications that the complete touch panel product must meet as shown below:

Item	Specifications	Remark
Transparency	$\geq 84\%$ Wave length 550 nm	Note 6.1
Haze	5% Max	
ITO pattern	Not invisible	Note 6.2
Hardness	6H	

Note 6.1: After stabilizing the panel, the measurement should be executed. Measurement should be executed in a stable, windless and dark room. Optical specifications are measured by Nippon, NDH-5000 meter 1.0 degree field of view at a distance of 35 cm and normal direction.

Note 6.2: Touch panel should be inspected so that ITO pattern is not visible to the human eye under certain condition as normal light and a distance of 35 cm.

7 FUNCTIONAL BLOCKS

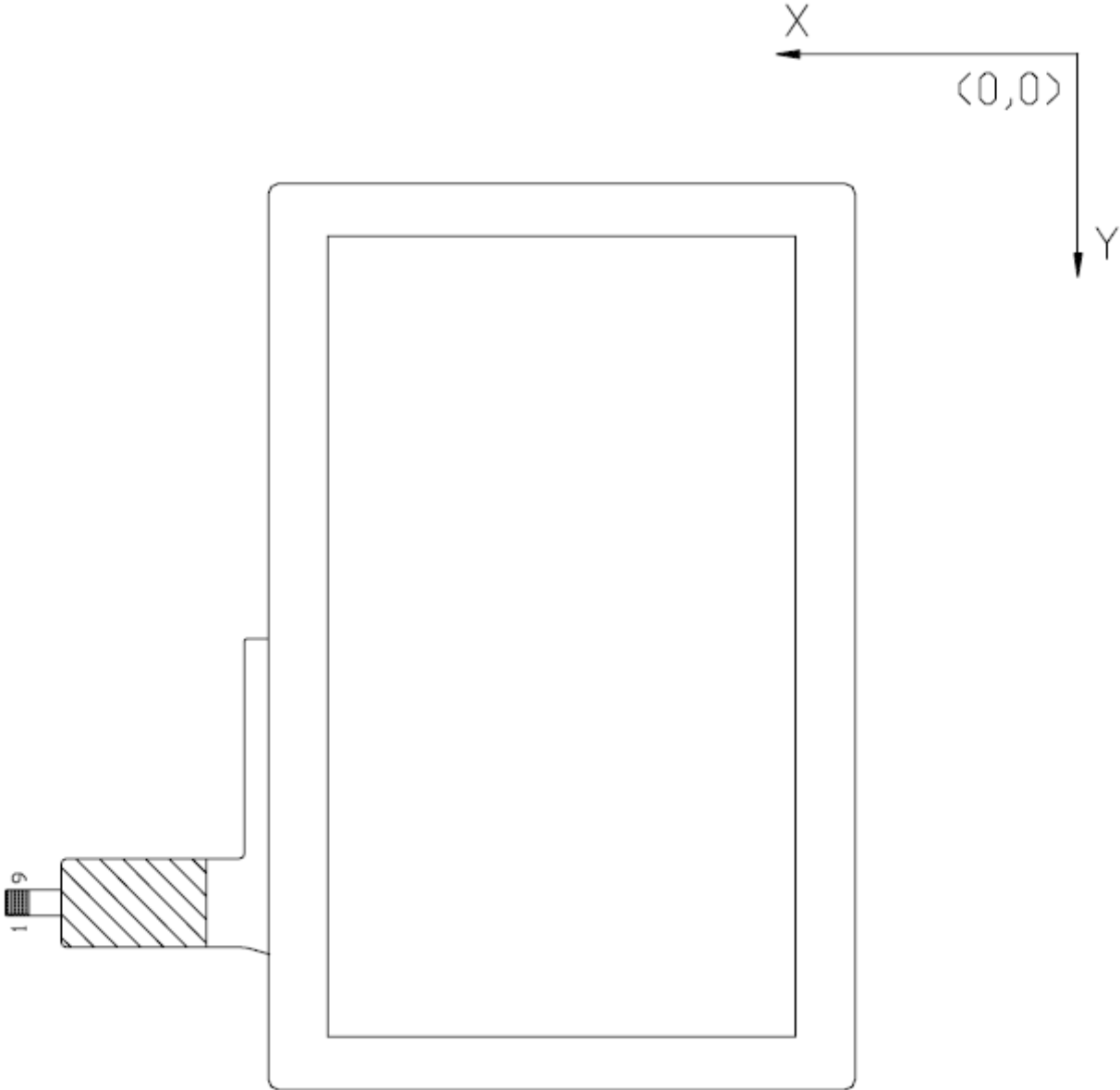

Communication protocol: I2C
IC: FT5406
Slave address is: 0X38 (7bit)

8 I2C

The I2C is always configured in the Slave mode. The data transfer format is shown in the Figure.

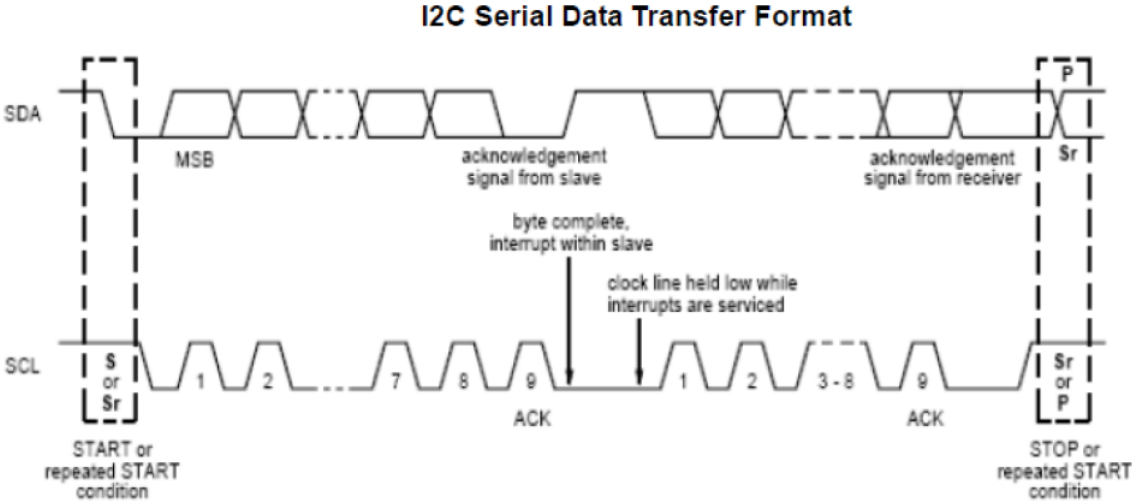

I2C master write, slave read

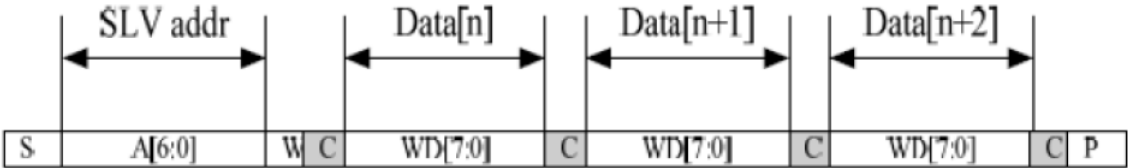

I2C master read, slave write

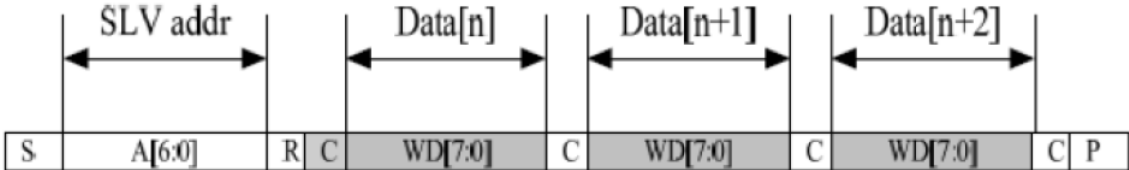

Table 1 lists the meanings of the mnemonics used in the above figures.

Table 1 Mmonics Description

Mnemonics	Description
S	I2C Start or I2C Restart
A[6:0]	Slave address A[6:4]: 3'b011 A[3:0]: data bits are identical to those of I2CCON[7:4] register.
W	1'b0: Write
R	1'b1: Read
C	ACK
P	STOP: the indication of the end of a packet (if this bit is missing, S will indicate the end of the current packet and the beginning of the next packet)

I2C Interface Timing Characteristics is shown in Table 2

Table 2 I2C Timing Characteristics

Parameter	Unit	Min	Max
SCL frequency	KHz	0	400
Bus free time between a STOP and START condition	us	4.7	\
Hold time (repeated) START condition	us	4.0	\
Data setup time	ns	250	\
Setup time for a repeated START condition	us	4.7	\
Setup Time for STOP condition	us	4.0	\

9 RELIABILITY TEST

Item	Specifications	Condition
Constant Temperature/Humidity	60°C/90%RH, 120 hrs	Reliability test may cause the film to slightly puffed, yet the functions stays intact. Note 1, 2
High Temperature	70°C, 120 hrs	
Low Temperature	-20°C, 120 hrs	
Thermal Cycle	-10°C~60°C (1.0 hr each), 100 cycles (within 24hr)	
ESD	HBM 5KV	Non-operation
	Contact 8KV	
	Air 15KV	

Note 1: The test samples have recovery time for 4 hours at room temperature before the function check. In the standard conditions, there is no touch panel function NG issue record.

Note 2: All the cosmetic specifications are judged before reliability stress.

10 DURABILITY

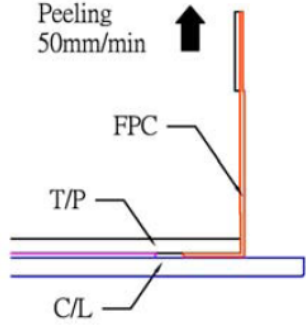
Item		Specifications	Condition
Panel	Impact	Steel Ball Weight: 50±2g Impact Height : 50 cm	1 time, no damage [Impact at center area]
	Hardness	6H pencil, pressure 1N/45° (JIS K-5400)	≧ 6H
FPC	Peeling (vertical 90°)	strength: ≧ 400g/cm pull rate: 50mm/min 1. FPC holder edge should be in alliance with FPC edge. 2. FPC center line should be in alliance with FPC holder center, to avoid shear force.	Peeling (NG) 
	Bending Test	Bending 10times Min	Function should be OK
Back Side Adhesive	Adhesive Test	strength: ≧ 1000g/cm	Peeling (NG)

11 QUALITY ASSURANCE SPECIFICATION

The criteria could be following the description as below:

1. Environment: $22 \pm 3^{\circ}\text{C}$, Inspection distance: $30 \pm 10\text{cm}$.
2. Angle of Visual: $30^{\circ}\sim 90^{\circ}$.
3. Lighting illumination: 17W fluorescent lamp is used appearance inspection.
Detail settings are shown in figure 1 & 2.
4. Minor impurities outside viewing area are acceptable unless their existence affect electrical functions.

Figure 1:

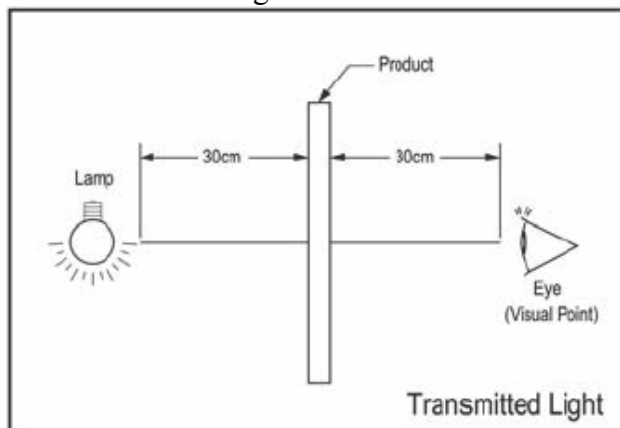
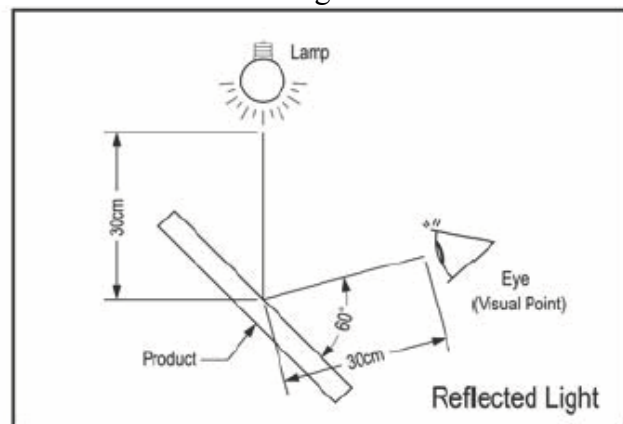
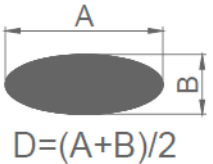
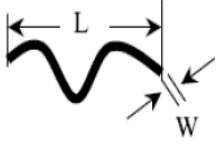
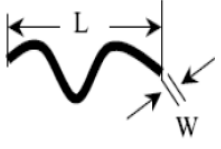
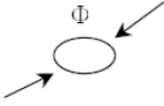
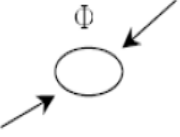
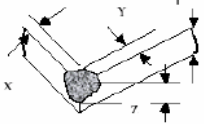
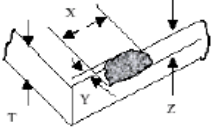

Figure 2:



Item	Specifications	Picture
Particle	(1) $D \leq 0.2$ OK (2) $0.2 < D \leq 0.3$, $n \leq 2$, distance over 5mm (3) $0.3\text{mm} < D \leq 0.4\text{mm}$, $n \leq 1$, (4) $D > 0.4\text{mm}$ NG	
Linear Object	(1) $W \leq 0.1$ OK (2) $0.1 < W \leq 0.2$ and $L \leq 5.0$, total ≤ 2 OK (3) $W > 0.2$ NG Remark: the particle will be ignored when it is removable by cleaning.	
Scratch	(1) $W \leq 0.02$ OK (2) $0.02 < W \leq 0.05$ and $L \leq 5\text{mm}$, total ≤ 3 OK, distance over 5mm (3) $0.05 < W \leq 0.1$ and $L \leq 5\text{mm}$, total ≤ 2 OK (4) $W > 0.1$ NG	
Bubble	(1) $D \leq 0.2$ OK (2) $0.2 < D \leq 0.3$, $n \leq 3$, (3) $0.3\text{mm} < D \leq 0.5\text{mm}$, $n \leq 2$, (4) $D > 0.5\text{mm}$ NG	
Dent	(1) $D \leq 0.1$ OK (2) $0.1 < D \leq 0.2$, $n \leq 2$, (3) $0.2\text{mm} < D \leq 0.3\text{mm}$, $n \leq 1$, (4) $D > 0.3\text{mm}$ NG	
Corner Chipping	$X < 2\text{mm}, Y < 3\text{mm}, Z < 1/2$ Glass thickness $N \leq 1$	
Edge Chipping	$X < 3\text{mm}, Y < 3\text{mm}, Z < 1/2$ Glass thickness $N \leq 1$	
Crack	Not allowed	