

LIQUID CRYSTAL DISPLAY MODULE

Product Specification

CUSTOMER	Standard	
PRODUCT NUMBER	DET057QVNCNT0-1A	
CUSTOMER APPROVAL		Date

INTERNAL APPROVALS		
Product Mgr	Doc. Control	Electr. Eng
Bruno	Luo	Zhe
Recaldini	Luo	Kou
Date: 05/03/13	Date: 05/03/13	Date: 05/03/13

Approval for Specification only

Approval for Specification and Sample

Product No.	DET057QVNCNT0-1A	REV. A

Page	1 / 22
------	--------

REVISION RECORD

Ver.	Date	Page	Chapt.	Comment
A	22-02-13			First Release

Contents

1. General Description and Features	4
1.1 Features	4
1.2 LCD Module	4
2. Mechanical Information	4
3. Electrical Specifications	5
3.1 Absolute Max. Ratings	5
3.2 Electrical Characteristics	6
3.3 AC Timing Characteristic.....	7
3.4 Back-Light Unit	11
4. Optical Characteristics	12
4.1 Optical characteristic of the LCD.....	12
5. I/O Terminal	14
5.1 Pin Assignment	14
5.2 Block Diagram.....	15
5.3 Back-light Unit (BLU)	15
5.4 Basic Display Color and Gray Scale	16
6. Reliability Condition	17
7. Dimensional Outlines	18
8. Incoming Inspection Standards	19

1. General Description and Features

DET057QVNCNT0-1A is a transmissive type color active matrix TFT (Thin Film Transistor) liquid crystal display (LCD) that uses amorphous silicon TFT as a switching device. This model is composed of a TFT-LCD module, a driver circuit and a back-light unit. Graphics and texts can be displayed on a QVGA 320 (W) x 3 x 240 (H) dots with 16.7M colors by supplying 24 bits data signal (8bits/each color). The following table described the features of DET057QVNCNT0-1A.

1.1 Features

- Transmissive and back-light with 21th LEDs are available.
- TN (Twisted Nematic) mode.
- 8 Bits 8080 system interface
- RoHS Compliance

1.2 LCD Module

Item	Specification	Unit
Screen Size	5.7 inches	Diagonal
Display Resolution	320 (H) x 240 (V)	Pixel
Active Area	115.20 (H) x 86.40 (V)	mm
Display Mode	Normally white mode/ Transmissive/ Wide view	--
Pixel Arrangement	R,G,B Vertical Tripe	--
Pixel size	120 x 360	um
TFT Control IC	SSD1963	--
Viewing Direction	12 o'clock	--
Input Interface	8 Bits i80 system interface	--

2. Mechanical Information

Item	Min.	Typ.	Max.	Unit	Note
Module Size	Horizontal (H)	--	144.00	--	mm (1,2,3)
	Vertical (V)	--	104.60	--	mm (2)
	Thickness (T)	--	13.0	--	mm (1,3)
Weight	--	(152)	--	g	--

Note (1) Not include FPC. Refer to the Outline Dimension Drawing as attached.

(2) Back-light unit is included.

(3) Excluding backlight cables.

3. Electrical Specifications

3.1 Absolute Max. Ratings

3.1.1 Absolute Ratings of Environment

If the operating condition exceeds the following absolute maximum ratings, the TFT LCD module may be damaged permanently.

(Ta=25±2°C, V_{SS}=GND=0)

Item	Symbol	Min.	Max.	Unit	Note
Storage temperature	T _{STG}	-30	80	°C	(1)
Operating temperature	T _{OPR}	-20	70	°C	(1,2,3)

Note (1) 95 % RH Max. (40 °C ≥ Ta). Maximum wet-bulb temperature at 39 °C or less. (Ta > 40 °C) No condensation.

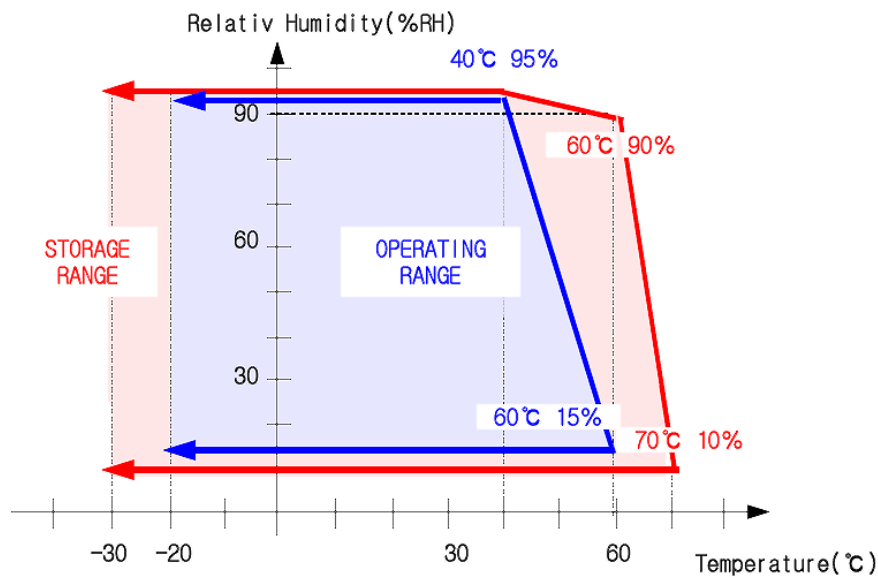

Note (2) In case of below 0°, the response time of liquid crystal (LC) becomes slower and the color of panel becomes darker than normal one. Level of retardation depends on temperature, because of LC's character

Note (3) Only operation is guaranteed at operating temperature. Contrast, response time, another display quality are evaluated at +25°C.

3.1.2 Electrical Absolute Maximum Ratings

(V_{SS}=GND=0)

Parameter	Symbol	Min.	Max.	Unit	Remark
Power supply voltage	V _{CC}	-0.3	5.0	V	

3.2 Electrical Characteristics

3.2.1 DC Electrical Characteristics of the TFT LCD

(Ta=25±2°C, V_{SS}=GND=0)

Item	Symbol	Min.	Typ.	Max.	Unit	Remark
Power supply	VCC	3.0	3.3	3.6	V	Note 1
Input Voltage for logic	H Level	V _{IH}	0.7V _{CC}	-	V	
	L Level	V _{IL}	0	-	0.3V _{CC}	V
Power Supply current	I _{CC}		TBD	-	mA	Note 2

Note1: V_{cc}-dip conditions

V_{cc}-dip conditions should also follow the V_{cc}-turn-on conditions

T_d ≤ 10ms

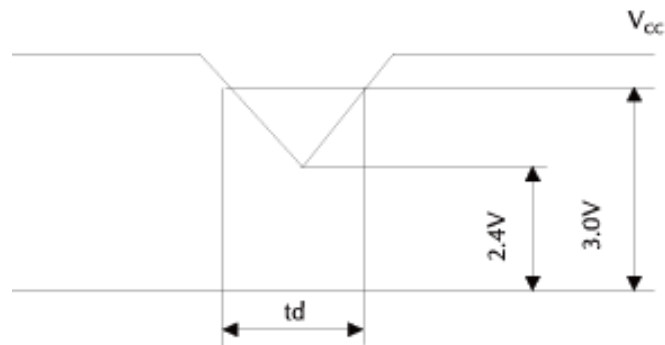

Note2: f_v =60Hz , Ta=25°C , Display pattern : 64 Gray pattern

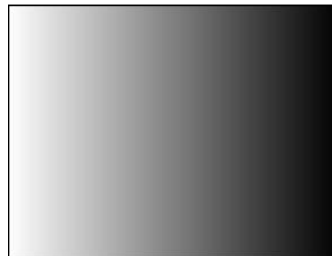

3.3 AC Timing Characteristic

3.3.1 Timing Condition

Signal	Parameter	Symbol	Min.	Typ.	Max.	Unit.	Remark	
DCLK	DCLK period	TOSC	-	156	-	ns		
	Frequency	FOSC	-	6.4	-	MHz		
RGB DATA	Data setup time	TSU	12	-	-	ns		
	Data hold time	THD	12	-	-	ns		
Hsync	Hsync period	TH	-	408	-	TOSC		
	Hsync pulse width	THS	5	30	-	TOSC		
	Back-Porch	THB		38		TOSC		
	Front-Porch	THF		20		TOSC		
	Hsync rising time(Setup)	TCr	12	-	-	ns		
	Hsync falling time(Hold)	TCf	12	-	-	ns		
Vsync	Vsync period	NTSC	-	262	-	TH		
		PAL	-	312	-	TH		
	Vsync pulse width	TVS	1	3	5	TH		
	Back-Porch	NTSC	TVB		15		TH	
		PAL			23		TH	
	Display Period	TVD		240		TH		
	Front Porch	NTSC	TVF		5		TH	
		PAL			46		TH	
	Vsync rising time(Setup)	TVr	12	-	-	ns		
	Vsync falling time(Hold)	TVf	12	-	-	ns		
Vsync falling to Hsync rising time for odd field	THVO	1	-	-	TOSC			
Vsync falling to Hsync falling time for even field	THVE	1	-	-	TOSC			
DEN	Vsync-DEN time	NTSC	-	18	-	TH		
		PAL	-	26	-	TH		
	Hsync-DEN time	THE	36	68	88	TOSC		
	DEN plus width	TEP	-	320	-	TOSC		

Note : If DEN is fixed to low, the SYNC mode is used. Otherwise DE mode is used. When SYNC mode is used, 1st data start from 68th CLK after H-sync falling

3.3.2 Clock and Data Waveform

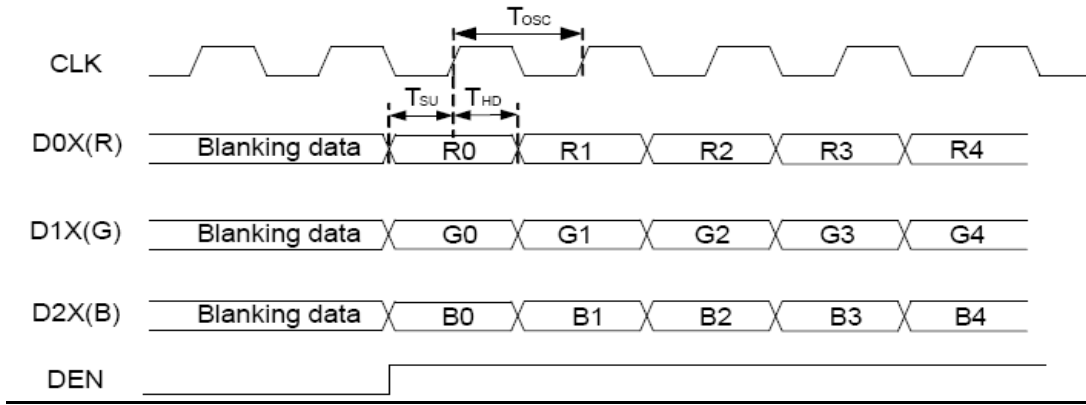

3.3.3 Clock and Sync waveforms

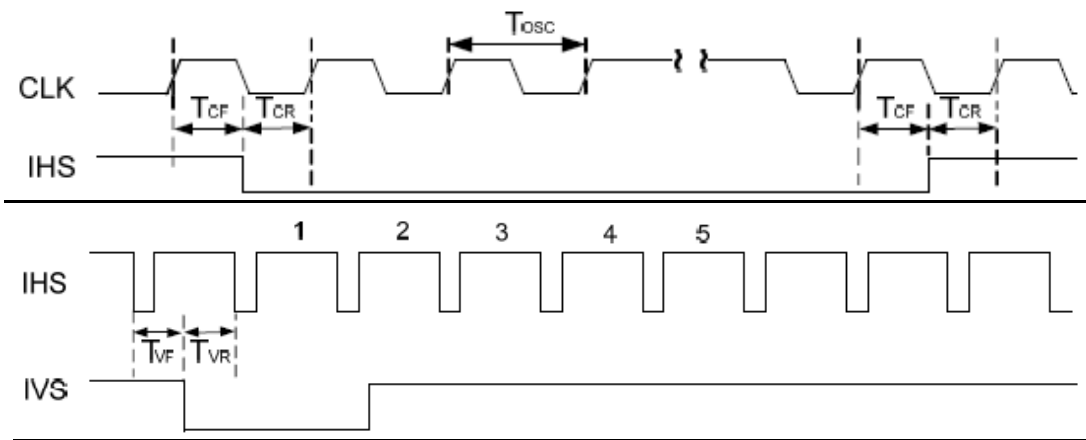

3.3.4 HS and horizontal control timing waveforms

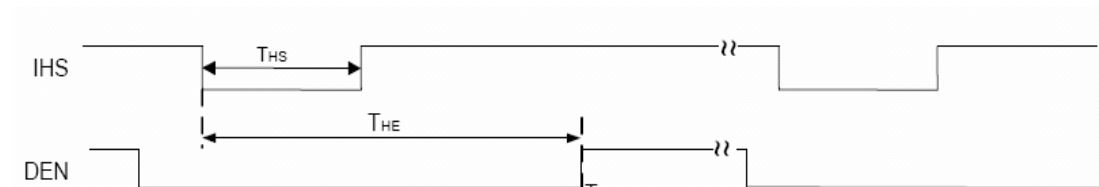

3.3.5 HS and vertical control timing waveforms

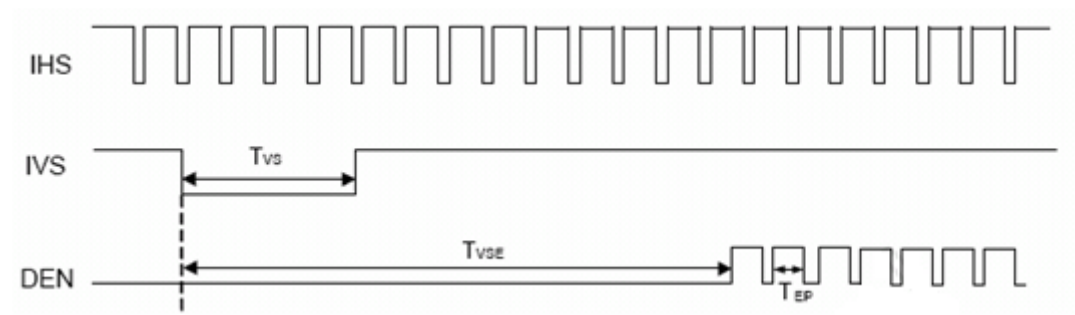

3.3.6 8080-series Interface Timing Condition

Parameter	Symbol	Min.	Typ.	Max.	Unit.	Remark
System Clock Frequency	fMCLK	1	-	110	MHz	Note
System Clock Period	tMCLK	1/ fMCLK	-	-	ns	Note
Control Pulse High Width Write	tpwchl	13	1.5* tMCLK	-	ns	
Control Pulse High Width Read	tpwchl	30	3.5* tMCLK	-	ns	
Control Pulse Low Width Write(next write cycle)	tpwchl	13	1.5* tMCLK	-	ns	
Control Pulse Low Width Write(next read cycle)	tpwchl	80	9* tMCLK	-	ns	
Control Pulse Low Width Read	tpwchl	80	9* tMCLK	-	ns	
Address Setup Time	tas	1	-	-	ns	
Address Hold Time	tah	2			ns	
Write Data Setup Time	tdsw	4	-	-	ns	
Write Data Hold Time	tdhw	1	-	-	ns	
Write Low Time	tpwll	12	-	-	ns	
Read Data Hold Time	tdhr	1	-	-	ns	
Address Time	tacc	32	-	-	ns	
Read Low Time	tpelr	36	-	-	ns	
Rise Time	tr	-	-	0.5	ns	
Fall Time	tf	-	-	0.5	ns	
Chip select setup time	tcs	2	-	-	ns	
Chip select hold time to read signal	tcsh	3	-	-	ns	

Note : System Clock Denotes external input clock(PLL-bypass) or internal generated clock(PLL-enabled)
Reference input clock=10MHz.
About Command setting, Please refer to [SSD1963](#).

3.3.7 Parallel 8080-series Interface Timing Diagram(Write Cycle)

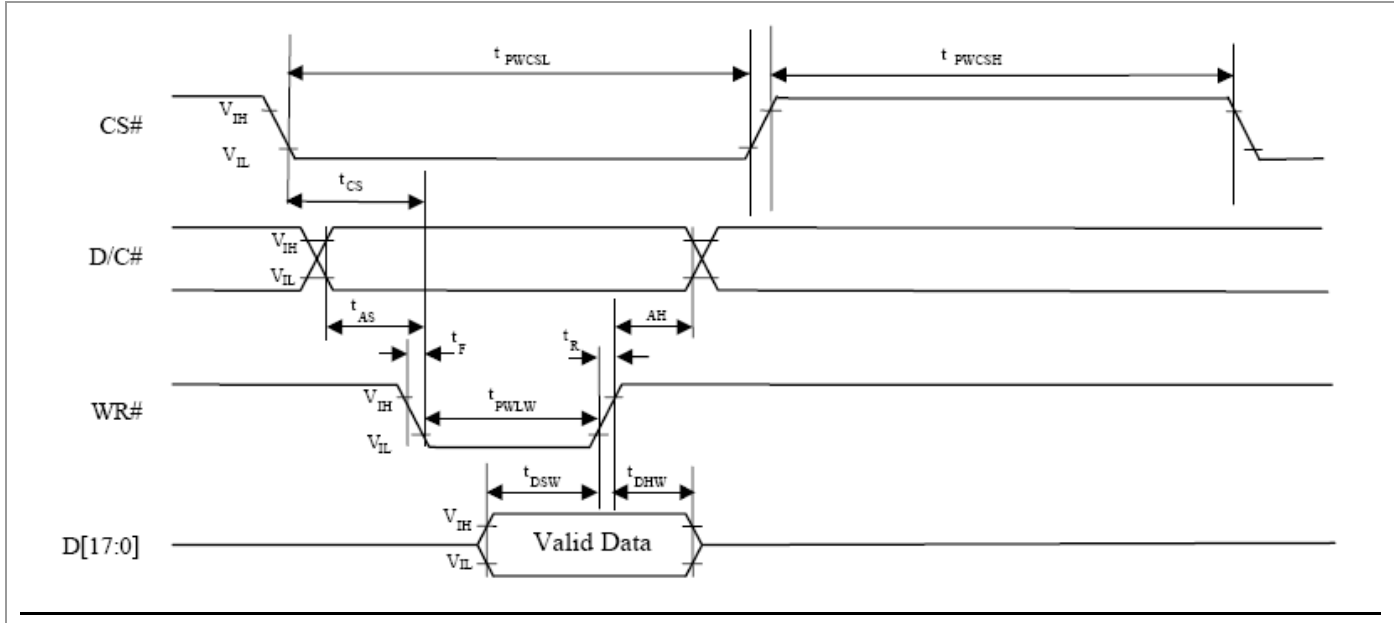

3.3.8 Parallel 8080-series Interface Timing Diagram(Read Cycle)

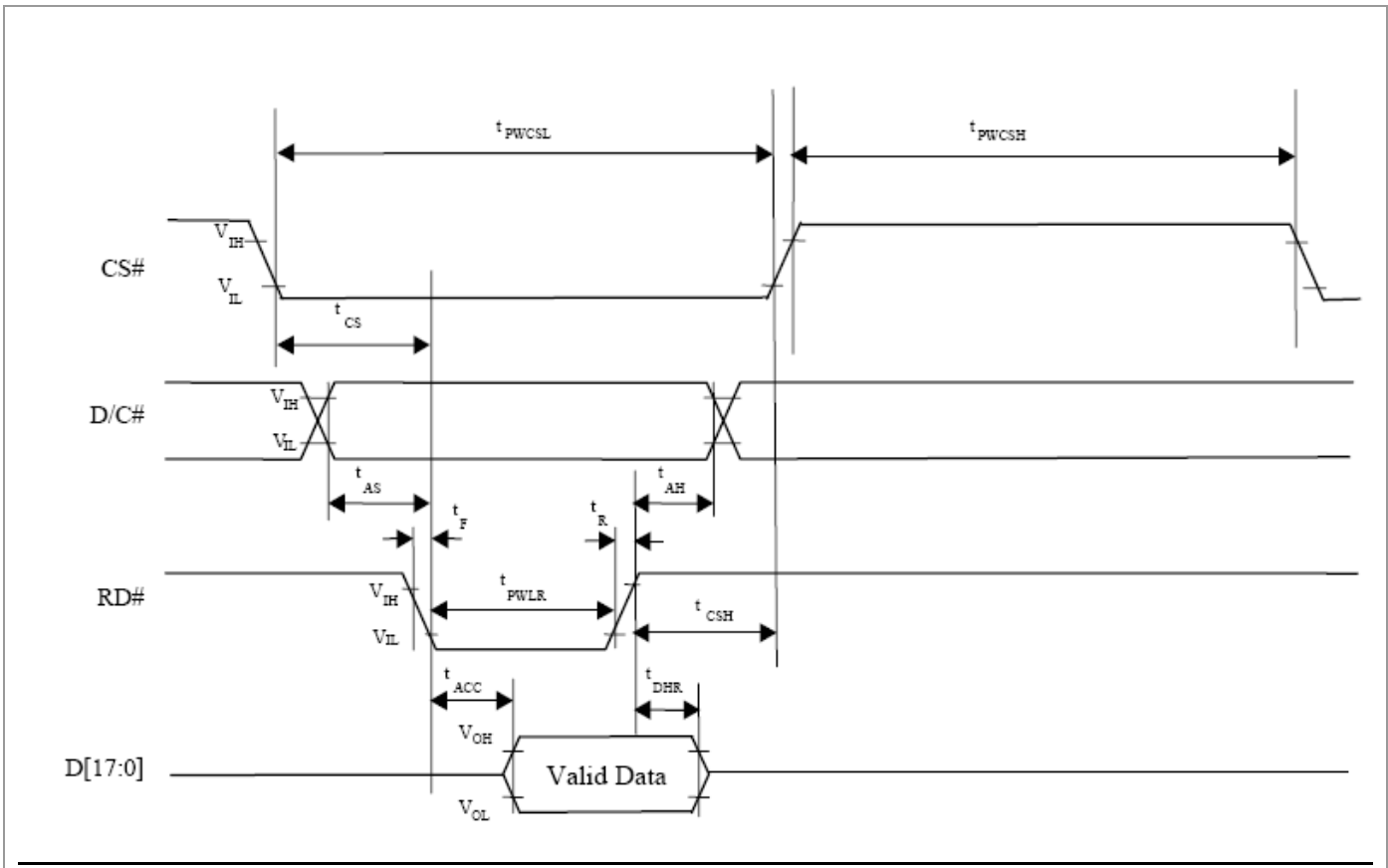

3.3.9 Mapping for writing an Pixel Data

Interface	Cycle	D[7]	D[6]	D[5]	D[4]	D[3]	D[2]	D[1]	D[0]
8 bits	1 st	R7	R6	R5	R4	R3	R2	R1	R0
	2 nd	G7	G6	G5	G4	G3	G2	G1	G0
	3 rd	B7	B6	B5	B4	B3	B2	B1	B0

3.4 Back-Light Unit

The Back-light system is an edge-lighting type with 21 white LED(Light Emitting Diode)s. The characteristics of 21white LEDs are shown in the following tables.

(Ta= Room Temp)

Characteristics		Symbol	Min.	Typ.	Max.	Unit	Note
Current of Back-light Unit		I_B	-	60	75	mA	(1)
Voltage of Back-light Unit		V_B	-	(23.1)	(24.5)	V	
Power Consumption		P_{BL}	-	(1386)	(1837.5)	mW	(2)
LED Life Time	25°C	-	(40000)	-	-	hr	(3)

Note (1) LEDS in 7 series x 3 parallel type.

(2) Where $I_B = 60\text{mA}$, $V_B = 23.1$, $P_{BL} = V_B \times I_B$

(3) The environmental conducted under ambient air flow ,at $T_a=25\pm 2^\circ\text{C}$,60%RH $\pm 5\%$

4. Optical Characteristics

4.1 Optical characteristic of the LCD

The following items are measured under stable conditions. The optical characteristics should be measured in a dark room or equivalent state with the methods shown in Note (1).

Measuring equipment: BM-5A, BM-7

Item	Symbol	Condition	Min	Type	Max	Unit	Note
Brightness			400	(450)	--	cd/m ²	
Response time	T _r	θ=0°	-	15	20	ms	.
	T _f		--	25	35	ms	
Contrast ratio	CR	At optimized viewing angle	300	(450)	--	--	
Color Gamut	NTSC %	--	--	50	--	%	
Color Chromaticity (CIE 1931)	Red	R _x	θ=0° Normal Viewing Angle	0.610	0.640	0.670	--
		R _y		0.314	0.344	0.374	
	Green	G _x		0.268	0.298	0.328	--
		G _y		0.553	0.583	0.613	
	Blue	B _x		0.107	0.137	0.167	--
		B _y		0.139	0.159	0.179	
	White	W _x		0.282	0.312	0.342	--
		W _y		0.309	0.339	0.369	
Viewing Angle (12H)	Hor.	θ _R	CR≥10	55	65	--	Degree
		θ _L		55	65	--	
	Ver.	φ _H		40	65	--	
		φ _L		55	50	--	

a. Test equipment setup

After stabilizing and leaving the panel alone shall be warmed up for the stable operation of LCM, the measurement should be executed. Measurement should be executed in a stable, windless, and dark room. Optical specifications are measured by Topcon BM-7(fast) with a viewing angle of 2° at a distance of 50cm and normal direction.

b. Definition of response time: Tr and Tf

The response time is defined as the following figure and shall be measured by switching the input signal for "black" and "white".

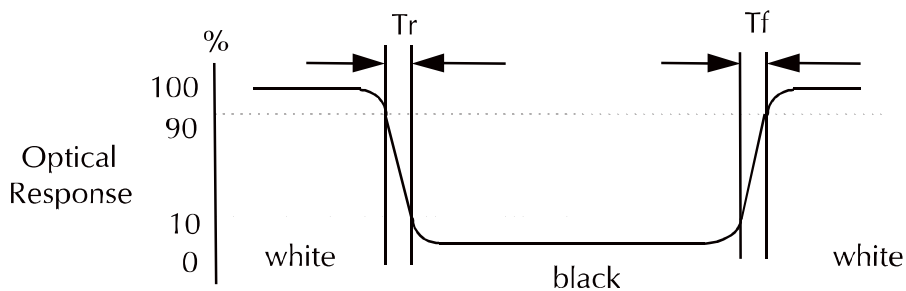

c. Definition of contrast ratio:

$$\text{Contrast Ratio (CR)} = \frac{\text{Brightness measured when LCD is at "white state"}}{\text{Brightness measured when LCD is at "black state"}}$$

d. Measured at the center area of the panel when all the input terminals of LCD panel are electrically opened.

e. View Angle

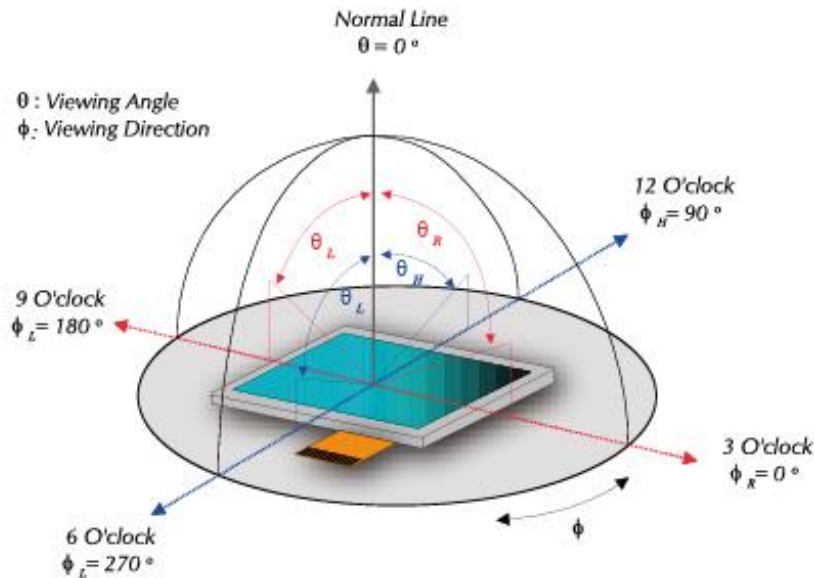

f. Definition of Luminance of White: Luminance of white at the center points

Light Source of Back-Light Unit	LED Type
---------------------------------	----------

g. Definition of White Uniformity

$$\text{White Uniformity} = \frac{\text{Min. luminance of white among 9-points}}{\text{Max. luminance of white among 9-points}}$$

h. The definition of Color Gamut -Color Chromaticity CIE 1931

Color coordinate of white & red, green, blue at center point.

Color Gamut : NTSC(%) = (RGB Triangle Area / NTSC Triangle Area) x 100

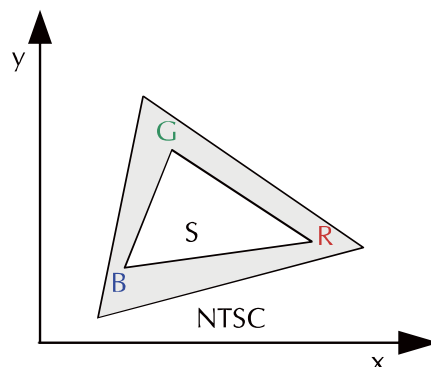

5. I/O Terminal

5.1 Pin Assignment

Pin No.	Symbol	I/O	Function	Remark
1	GND	P	GND	
2	VCC	P	Power supply	
3	NC	-	Not Connection	
4	D/C	I	Data/Command select	
5	WR	I	8080 mode :write signal	
6	RD	I	8080 mode :read signal	
7	D0	I	Data bus	
8	D1	I	Data bus	
9	D2	I	Data bus	
10	D3	I	Data bus	
11	D4	I	Data bus	
12	D5	I	Data bus	
13	D6	I	Data bus	
14	D7	I	Data bus	
15	CS	I	Chip select	
16	RES	I	Hardware Reset	
17	NC	-	Not Connection	
18	R/L	I	Horizontal display mode select signal L: Normal H: Left / Right reverse mode	Note5-1
19	U/D	I	Vertical display mode select signal H: Normal L: Up / Down reverse mode	Note5-1
20	NC	-	Not Connection	

Note5 - 1

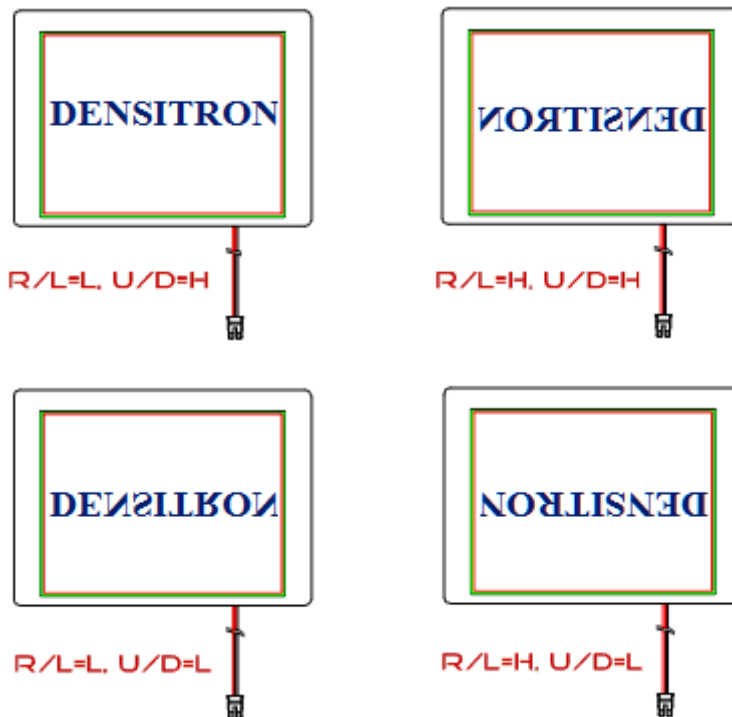

5.2 Block Diagram

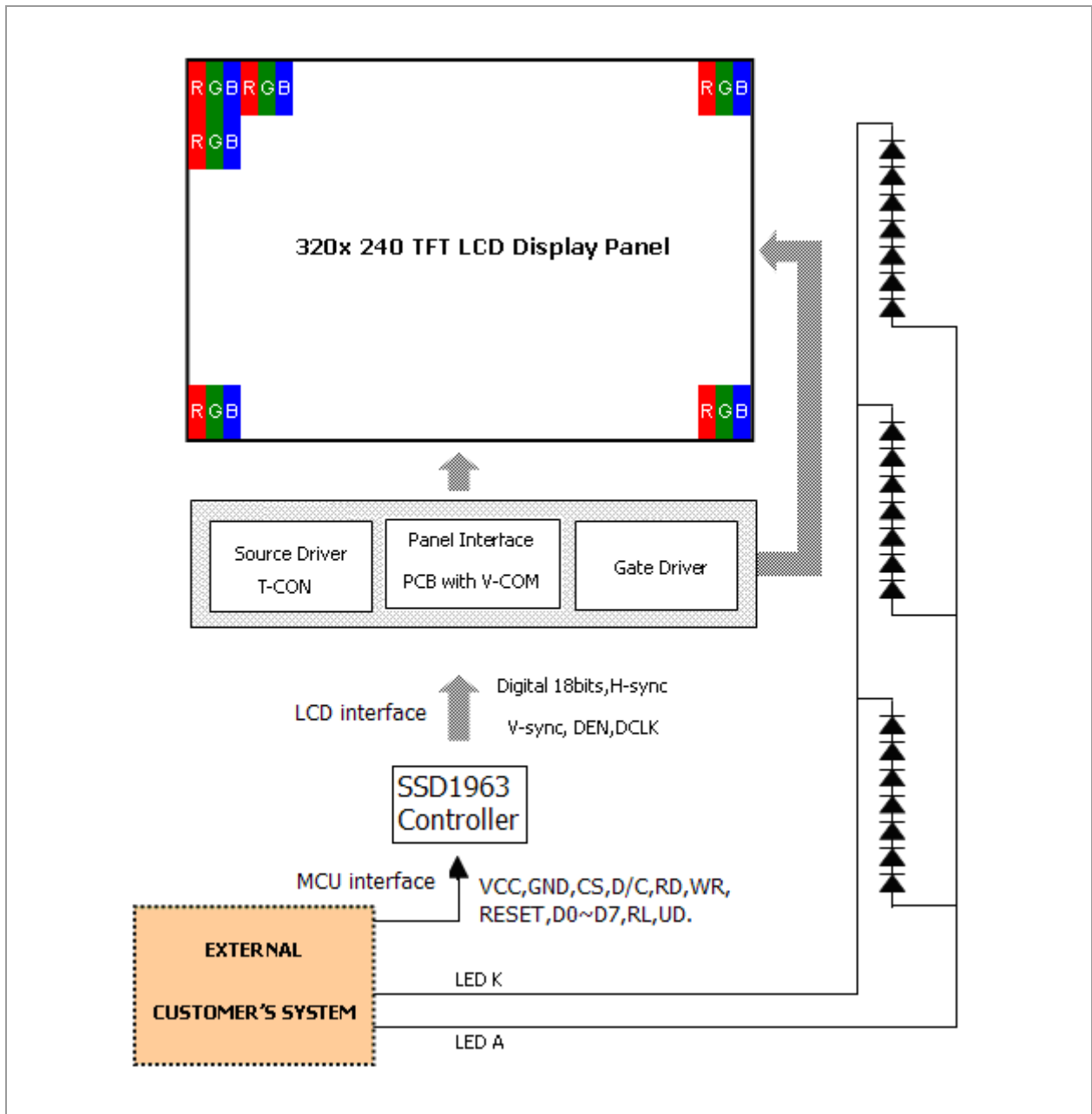

5.3 Back-light Unit (BLU)

Pin No.	Symbol	Function	Remark
1	LEDA	Power Supply for LED backlight	Red
2	LEDK	GND for LED backlight	Black

Connector: JST BHSR-02VS-1

5.4 Basic Display Color and Gray Scale

	Color & Gray Scale	Data Signal																							
		R7	R6	R5	R4	R3	R2	R1	R0	G7	G6	G5	G4	G3	G2	G1	G0	B7	B6	B5	B4	B3	B2	B1	B0
Basic Color	Black	0	0	0	0	0	0	0	0	0	0	0	0	0	0	0	0	0	0	0	0	0	0	0	
	Red(0)	1	1	1	1	1	1	1	1	0	0	0	0	0	0	0	0	0	0	0	0	0	0	0	
	Green(0)	0	0	0	0	0	0	0	0	1	1	1	1	1	1	1	1	0	0	0	0	0	0	0	
	Blue(0)	0	0	0	0	0	0	0	0	0	0	0	0	0	0	0	0	1	1	1	1	1	1	1	
	Cyan	0	0	0	0	0	0	0	0	1	1	1	1	1	1	1	1	1	1	1	1	1	1	1	
	Magenta	1	1	1	1	1	1	1	1	0	0	0	0	0	0	0	0	1	1	1	1	1	1	1	
	Yellow	1	1	1	1	1	1	1	1	1	1	1	1	1	1	1	1	0	0	0	0	0	0	0	
	White	1	1	1	1	1	1	1	1	1	1	1	1	1	1	1	1	1	1	1	1	1	1	1	
Red	Black	0	0	0	0	0	0	0	0	0	0	0	0	0	0	0	0	0	0	0	0	0	0		
	Red(1)	0	0	0	0	0	0	0	1	0	0	0	0	0	0	0	0	0	0	0	0	0	0		
	Red(2)	0	0	0	0	0	0	1	0	0	0	0	0	0	0	0	0	0	0	0	0	0	0		
	:	:	:	:	:	:	:	:	:	:	:	:	:	:	:	:	:	:	:	:	:	:	:		
	Red(31)	0	1	1	1	1	1	1	1	0	0	0	0	0	0	0	0	0	0	0	0	0	0		
	:	:	:	:	:	:	:	:	:	:	:	:	:	:	:	:	:	:	:	:	:	:	:	:	
	Red(62)	1	1	1	1	1	1	1	0	0	0	0	0	0	0	0	0	0	0	0	0	0	0		
Red(63)	1	1	1	1	1	1	1	1	0	0	0	0	0	0	0	0	0	0	0	0	0	0			
Green	Black	0	0	0	0	0	0	0	0	0	0	0	0	0	0	0	0	0	0	0	0	0	0		
	Green(1)	0	0	0	0	0	0	0	0	0	0	0	0	0	0	0	1	0	0	0	0	0	0		
	Green(2)	0	0	0	0	0	0	0	0	0	0	0	0	0	0	1	0	0	0	0	0	0	0		
	:	:	:	:	:	:	:	:	:	:	:	:	:	:	:	:	:	:	:	:	:	:	:		
	Green(31)	0	0	0	0	0	0	0	0	0	1	1	1	1	1	1	1	0	0	0	0	0	0		
	:	:	:	:	:	:	:	:	:	:	:	:	:	:	:	:	:	:	:	:	:	:	:		
	Green(62)	0	0	0	0	0	0	0	0	1	1	1	1	1	1	1	0	0	0	0	0	0	0		
Green(63)	0	0	0	0	0	0	0	0	1	1	1	1	1	1	1	1	0	0	0	0	0	0			
Blue	Black	0	0	0	0	0	0	0	0	0	0	0	0	0	0	0	0	0	0	0	0	0	0		
	Blue(1)	0	0	0	0	0	0	0	0	0	0	0	0	0	0	0	0	0	0	0	0	0	1		
	Blue(2)	0	0	0	0	0	0	0	0	0	0	0	0	0	0	0	0	0	0	0	0	0	1		
	:	:	:	:	:	:	:	:	:	:	:	:	:	:	:	:	:	:	:	:	:	:	:		
	Blue(31)	0	0	0	0	0	0	0	0	0	0	0	0	0	0	0	0	1	1	1	1	1	1		
	:	:	:	:	:	:	:	:	:	:	:	:	:	:	:	:	:	:	:	:	:	:	:		
	Blue(62)	0	0	0	0	0	0	0	0	0	0	0	0	0	0	0	0	1	1	1	1	1	1		
Blue(63)	0	0	0	0	0	0	0	0	0	0	0	0	0	0	0	0	1	1	1	1	1	1			

Each basic color can be displayed in 256 gray scales from 8 bit data signals. With the combination of total 24 bit data signals, the 16.7M-color display can be achieved on the screen.

6. Reliability Condition

No change on display and in operation under the following test condition.

Condition: Unless otherwise specified, tests will be conducted under the following condition.

Temperature: 20±5°C.

Humidity: 65±5%RH.

Tests will be not conducted under functioning state.

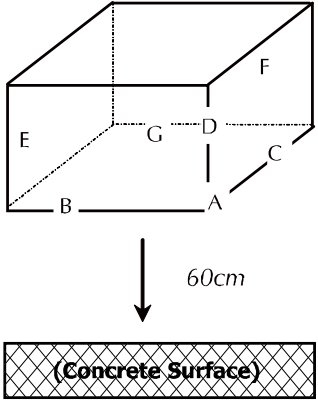
No.	Parameter	Condition	Notes
1	High Temperature Operating	70°C±2°C, 240hrs (Operation state).	-
2	Low Temperature Operating	-20°C±2°C, 240hrs (Operation state).	-
3	High Temperature Storage	80°C±2°C, 240hrs.	-
4	Low Temperature Storage	-30°C±2°C, 240hrs.	-
5	High Temperature and High Humidity Operation Test	60°C±2°C, 90%, 240hrs.	-
6	Vibration Test	Total fixed amplitude: 1.5mm. Vibration Frequency: 10~55Hz. One cycle 60 seconds to 3 direction of X, Y, Z each 15 minutes.	-
7.	Drop Test	To be measured after dropping from 60cm high on the concrete surface in packing state.  <i>Dropping method corner dropping:</i> <i>A corner: Once edge dropping.</i> <i>B, C, D edge: Once face dropping.</i> <i>E, F, G face: Once.</i>	-

7. Dimensional Outlines

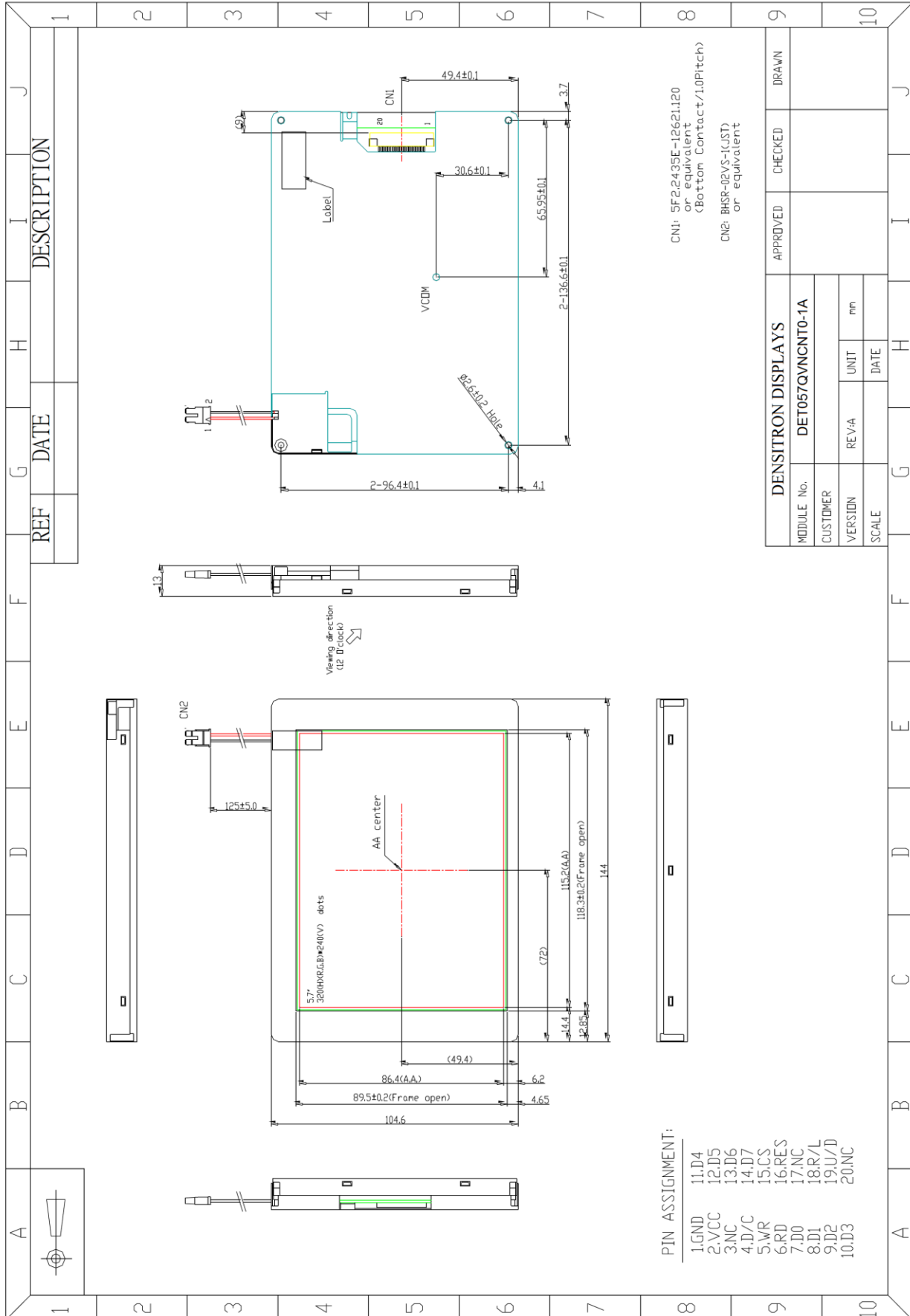

PIN ASSIGNMENT:

- 1.GND
- 11.D4
- 2.VCC
- 12.D5
- 3.NC
- 13.D6
- 4.D/C
- 14.D7
- 5.WR
- 15.CS
- 6.RD
- 16.RES
- 7.D0
- 17.NC
- 8.D1
- 18.R/L
- 9.D2
- 19.U/D
- 10.D3
- 20.NC

CN1: 5F2.2435E-12621120
or equivalent
(Bottom Contact/1.0Pitch)

CN2: BHSR-02VS-1(CJT)
or equivalent

DENSITRON DISPLAYS				APPROVED	CHECKED	DRAWN
MODULE No.	DET057QVNCNT0-1A					
CUSTOMER		REV:A	UNIT			
VERSION			mm			
SCALE			DATE			

Product No.	DET057QVNCNT0-1A	REV. A
-------------	------------------	--------

Page	18 / 22
------	---------

8. Incoming Inspection Standards

8.1 Inspection and Environment Conditions

8.1.1 Inspection Conditions:

- (1) Inspection Distance: 35 cm±5cm
- (2) View Angle : Light-on Inspection Angle : ±5°
Cosmetic Inspection Angle : ±45°

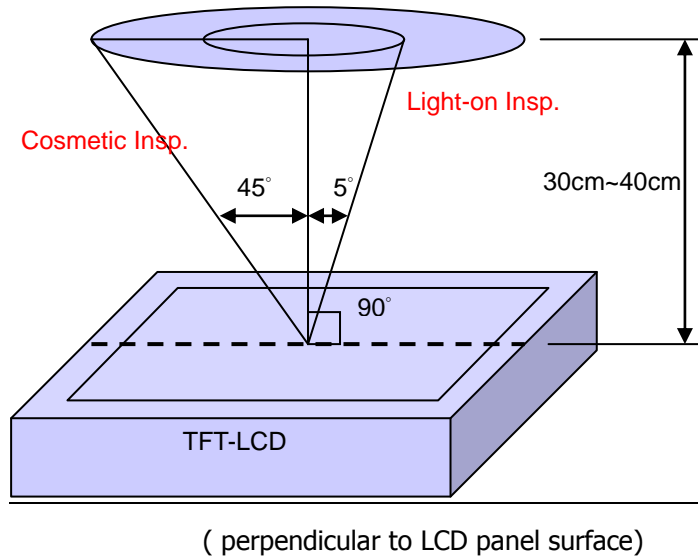

8.1.2 Environment Conditions:

Ambient Temperature		23°C ±5°C
Ambient Humidity		55±10%RH
Ambient Illumination	Cosmetic Inspection	more than 600 Lux
	Functional Inspection	300~500 Lux

8.1.3 Sampling Conditions:

- (1) Lot Size: Quantity of shipment lot per model
- (2) Sampling Method:

Sampling Plan		MIL-STD-105E
		Normal Inspection, Single Sampling Level II
AQL	Major Defect	1.0%
	Minor Defect	1.5%

(3) The classification of Major(MA) and Minor(MI) defects is shown as 3. Inspection Criteria.

8.1.4 Inspection Criteria

8.1.4.1 Cosmetic Inspection(Panel):

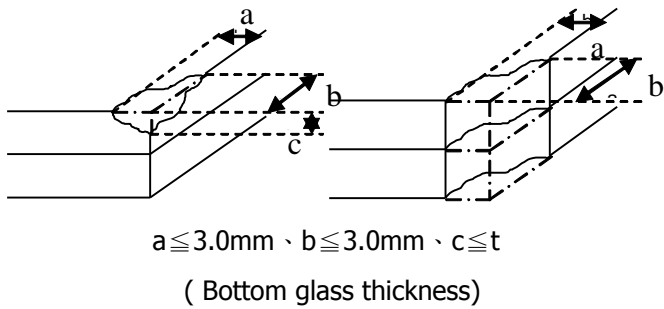
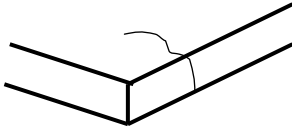
Item	Judgment Criteria	Classification
Chipping on Panel	 <p>$a \leq 3.0\text{mm}$ · $b \leq 3.0\text{mm}$ · $c \leq t$ (Bottom glass thickness)</p>	MA
Scratch on Panel *Note-2	<p>$W \leq 0.05\text{mm}$ or $L < 5\text{mm}$: Ignored $0.05\text{mm} < W \leq 0.1\text{mm}$ and $L \leq 5\text{mm}$: $N \leq 5$ $W > 0.1\text{mm}$ or $L > 5\text{mm}$: Not allowed</p>	MI
Bubble or Dent on Panel *Note-3	<p>$D \leq 0.2\text{mm}$: Ignored $0.2\text{mm} < D \leq 0.3\text{mm}$: $N \leq 5$ $D > 0.3\text{mm}$: Not allowed</p>	MI
Panel Crack	 <p>Not Allowed crack</p>	MA
Bezel Deformation	Obvious deformation is not allowed.	MI
Bezel Oxidation	Not allowed if it rusts continuously over 1 cm (It is out of warranty with rusted tin plate)	MI
Bezel Scratch	$L \leq 20\text{mm}$, $W \leq 0.2$, $N \leq 3$	MI
Metal Squash Dent /Flange(Front Side)	$D(W) \leq 1, L \leq 3, N \leq 3;$	MI
B/L High Voltage Wire Denudation	Not allowed	MA
Polarizer flaw or leak out resin	Defect is defined as the active area.	MI
Outline Dimension	Must in Spec, refer to related product spec.	MI

8.1.4.2 Functional Inspection:

Item	Judgment Criteria			Classification
	Area(Note1)	I	O	
Point Defect	Bright dot	Random	2	
		2 dots adjacent	0	0
		3 dots adjacent or more	0	0
	Dark dot	Random	3	
		2 dots adjacent	0	
		3 dots adjacent or more	0	0
	Total Dot Defect		5	
	Distance	Distance between Bright and Bright dot	$L \geq 5\text{mm}$	
		Distance between Bright and Dark dot	$L \geq 5\text{mm}$	
		Distance between Dark dot	$L \geq 5\text{mm}$	
(1) It is defined as Point Defect if defect area $> 0.5\text{dot}$ (2) It is ignored if defect area $\leq 0.5\text{dot}$ (3) Weak point defect will be defined as Bright Dot if it can be observed through ND filter 5%(Full Screen Black Inspection)				MI
Line Defect	Obvious vertical or horizontal line defect is not allowed.			MA
Mura	Not allowed if it can be observed through ND Filter 5 %			MI
Foreign Material in spot shape *Note-3	$D \leq 0.2\text{mm}$: Ignored $0.2\text{mm} < D \leq 0.5\text{mm}$: $N \leq 8$ $D > 0.5\text{mm}$: Not allowed			MI
Foreign Material in line or spiral shape *Note-4	$W \leq 0.05\text{mm}$ or $L \leq 5\text{mm}$: Ignored $0.05\text{mm} < W \leq 0.2\text{mm}$ and $L 1.0\text{mm} \leq 5\text{mm}$: $N \leq 8$ $W > 0.2\text{mm}$ or $L > 5\text{mm}$: Not allowed			MI
Display Function Abnormal	No Malfunction can be allowed			MA

Note-1 : I/O Area Definition

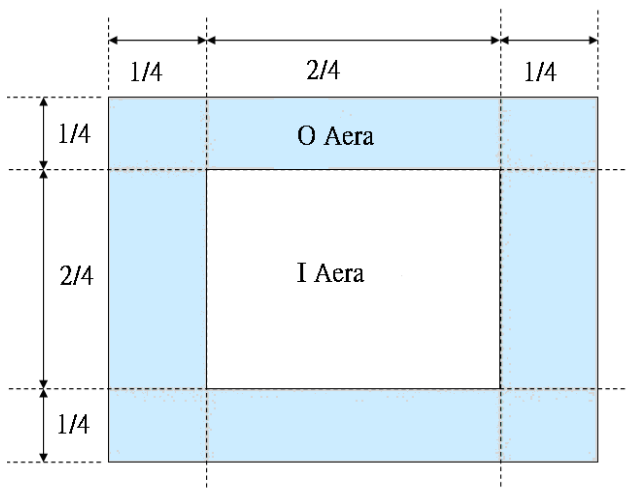

Note-2 : Polarizer Scratch

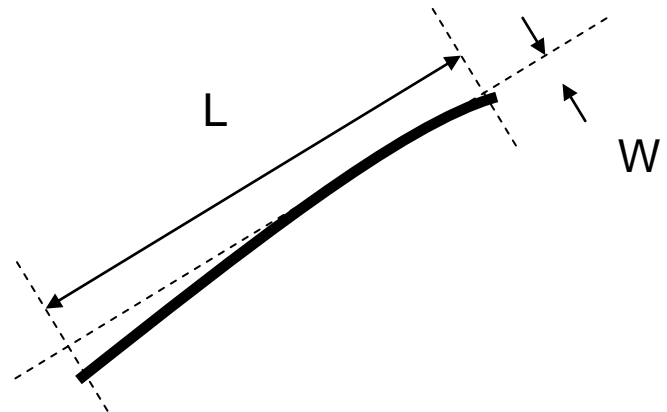

Note-3 : Spot Foreign Material
($W \geq L / 4$)

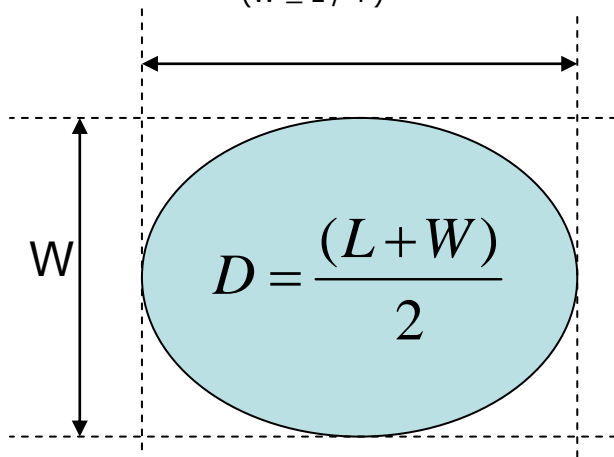

Note-4 : Line or Spiral Foreign Material
($W < L / 4$)

