

Proximity Sensors Capacitive Thermoplastic Polyester Housing Types CA, M12, DC, Teach-in

TRIPLESIELD™

CARLO GAVAZZI

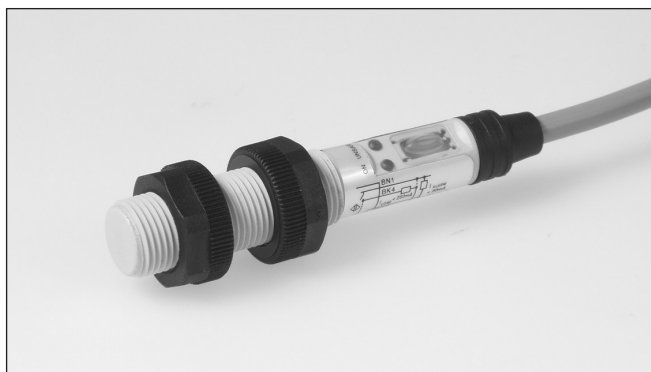

- Featuring **TRIPLESIELD™** Sensor Protection
- Sensing distance: 0.5 - 8 mm
- Teach-in of sensing distance via push-button or wire
- Automatic detection of NPN or PNP load
- Selectable make or break switching by means of the Teach-in function
- Protection: short-circuit, transients and reverse polarity
- Humidity compensation
- Alarm output

Product Description

Capacitive proximity switches with a sensing distance of either 4 mm flush mounted in metal or 8 mm non-flush mounted. The switching points can be altered by means of the

teach-in function. 3-wire DC output with selectable make (NO) or break (NC) switching and NPN Alarm. Grey polyester housing with 2 m PVC cable or M12 plug.

Ordering Key

CA12CLC08BPM1RT

Capacitive proximity switch	CA
Housing diameter (mm)	12
Housing material	C
Housing length	08
Detection principle	B
Rated operating dist. (mm)	M1
Output type	R
Output configuration	
Connection type	
Remote teach	

Type Selection

Housing diameter	Rated operating distance (S _n)	Ordering no. Cable	Ordering no. Plug
M12	8 mm	CA12CLC08BPRT	CA12CLC08BPM1RT

Specifications

Sensing range (S_d) Non-flush mounted	0.5 - 8 mm, ref. target 24x24 mm ST37, 1 mm thick, grounded	Protection TRIPLESIELD™ protection Electrostatic discharge Burst Airborne HF Wire-conducted noise	Short-circuit, reverse polarity, transients
Flush mounted	0.5 - 4 mm, ref. target 12x12 mm ST37, 1 mm thick, grounded		30 kV 3 kV > 15 V/m > 10 V _{rms} (non-flush mounted) > 3 V _{rm} (flush mounted)
Sensitivity	Adjustable (Teach-in)	Response time OFF-ON (t_{on})	≤ 35 ms
Effective operating dist. (S_r)	0.9 x S _n ≤ S _r ≤ 1.1 x S _n	Response time ON-OFF (t_{off})	≤ 31 ms
Usable operating dist. (S_u)	0.8 x S _r ≤ S _u ≤ 1.2 x S _r	Power ON delay (t_v)	≤ 200 ms
Repeat accuracy (R)	≤ 5%	Frequency of operating cycles (f)	15 Hz
Hysteresis (H)	3 - 20%	Indication For output ON Power and signal stability	LED, yellow LED, green
Rated operational volt. (U_B)	10 to 40 VDC (ripple incl.)	Environment Installation category	III (IEC 60664, 60664A; 60947-1)
Ripple	≤ 10%	Degree of pollution	3 (IEC 60664, 60664A; 60947-1)
Output function	NPN/PNP (auto detect)	Degree of protection	IP 68 (24 hours) (IEC 60529; 60943-1)
Output switching function	N.O. or N.C. (teachable)		
Rated operational current (I_e)	≤ 200 mA (continuous)		
No-load supply current (I_o)	≤ 12 mA		
Voltage drop (U_d)	≤ 2.5 VDC @ max. load		
Minimum operational current (I_m)	≥ 1 mA		
OFF state current (I_i)	≤ 0.3 mA		



Specifications (cont.)

NEMA type	1, 2, 12	Cable gland Nuts	Polyester, softened Black, PA12
Operating temperature	-20 to +85°C (-4 to +185°F)	Connection Cable	PVC, 2 m, 4 x 0.25 mm ² Oil proof, grey M12 x 1 - 4 pin CONM14NF.. -series
Max. temperature on sensing face	120°C (248°F)		
Storage temperature	-40 to +85°C (-40 to +185°F)	Plug (M1) Cable for plug (M1)	
Vibration	10 to 150 Hz, 1 mm/15 g (IEC 60068-2)	Weight Cable version Plug version	110 g 30 g
Shock	30 g/77 ms, 3 pos, 3 neg per axis (IEC 60068-2-32)	Approvals	cULus (UL508)
Rated insulation voltage	500 VAC (rms)	CE-marking	Yes
Housing material Body	Grey thermoplastic polyester		

Adjustment Guide

The environments in which capacitive sensors are installed can often be unstable as regards to temperature, humidity, object distance and industrial (noise) interference. Because of this, Carlo Gavazzi offers

as standard features in all *TRIPLESIELD™* capacitive sensors a user-friendly sensitivity adjustment instead of a fixed sensing range. Likewise, these sensors provide an extended sensing range to accommodate

mechanically demanding areas and temperature stability to ensure high immunity to electromagnetic interference (EMI) and a minimum need for adjusting sensitivity if the temperature varies.

Note: Sensors are factory set (default) to nominal sensing range S_n .

Wiring Diagram

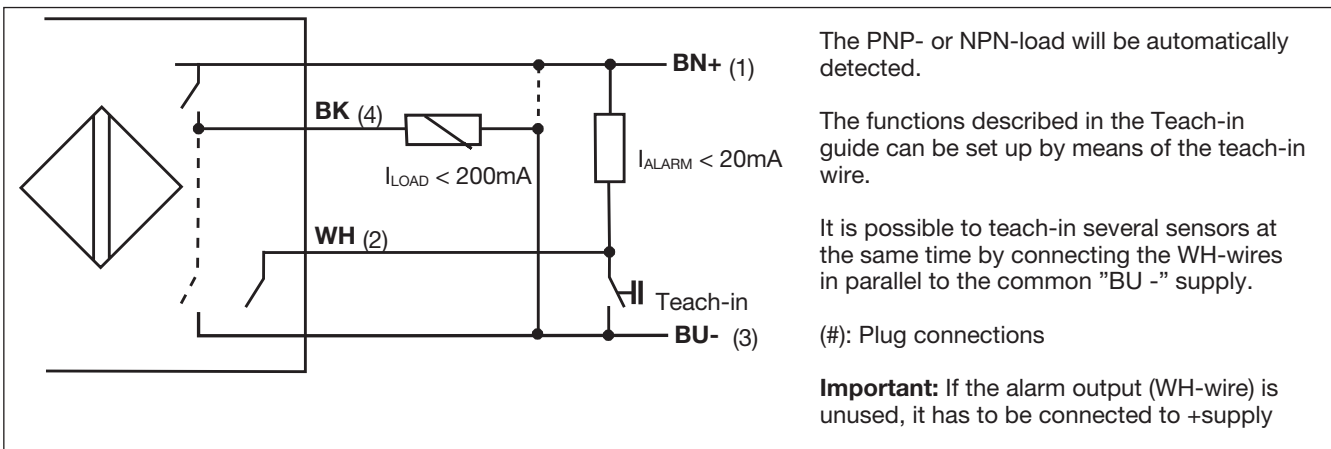

Detection Diagram

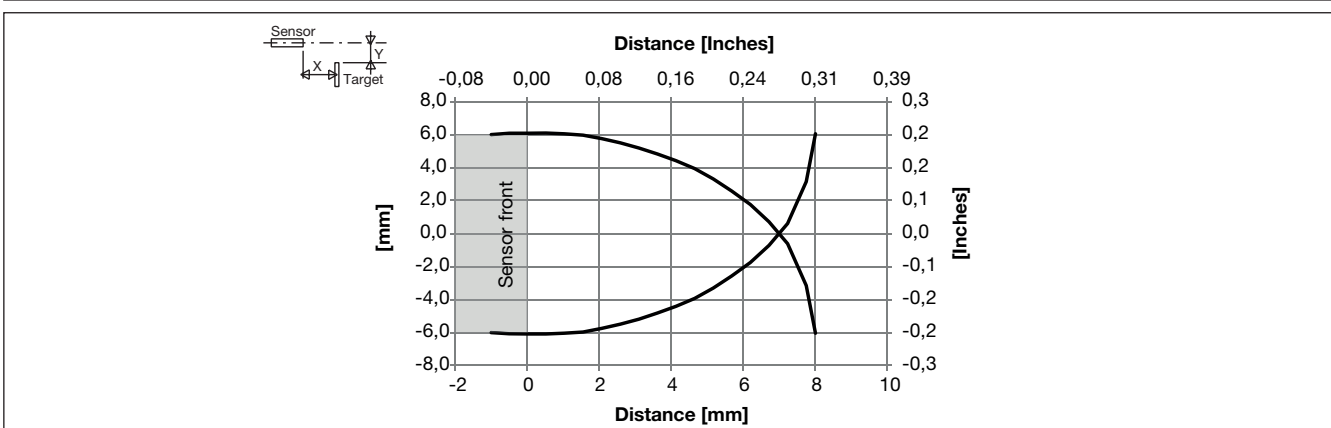

Dimensions

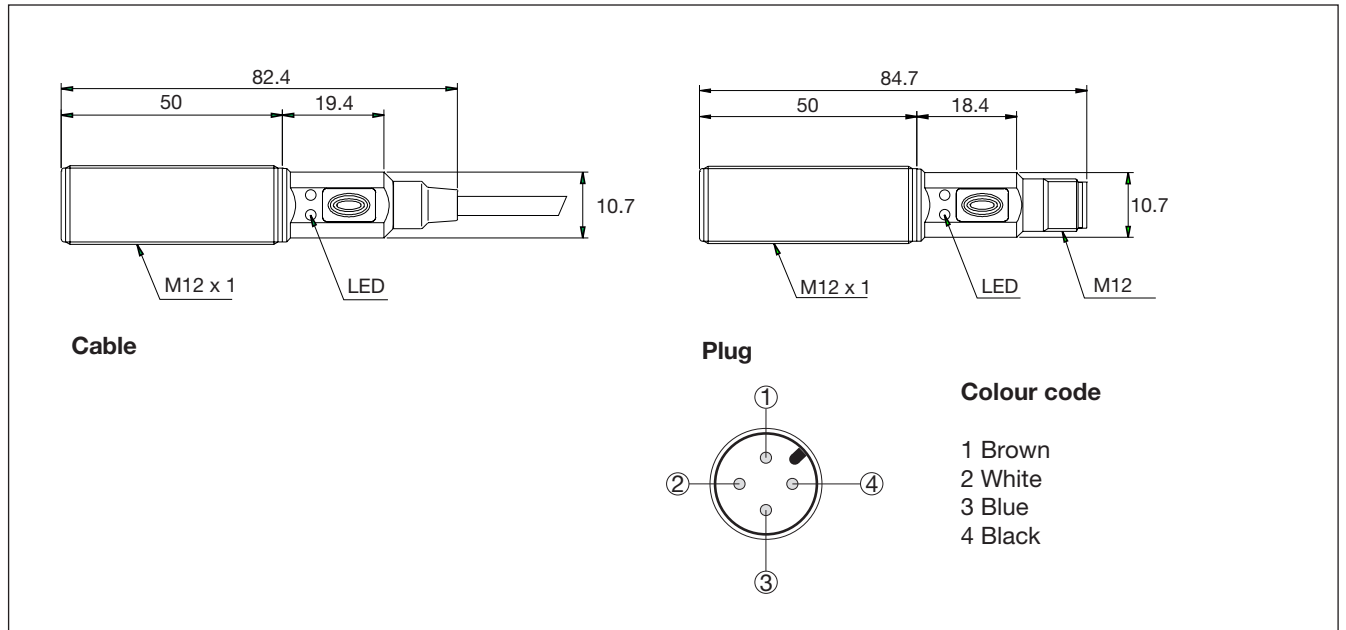

Installation Hints

Capacitive sensors have a unique ability to detect almost any material in liquid or solid form. Capacitive sensors are able to detect metallic as well as non-metallic objects. However, their traditional use is for non-metallic materials such as:

- **Plastics Industry**
Resins, regrinds or mould-

- ed products.
- **Chemical Industry**
Cleansers, fertilizers, liquid soaps, corrosives and petrochemicals.
- **Wood Industry**
Saw dust, paper products, door and window frames.
- **Ceramics & Glass Industry**
Raw materials, clay or

- finished products, bottles.
- **Packaging Industry**
Package inspection for level or contents, dry goods, fruits and vegetables, dairy products.

Materials are detected due to their dielectric constant. The bigger the size of an object, the higher the density of material, the better or eas-

ier it is to detect the object. The nominal sensing distance for a capacitive sensor is referred to a grounded metal plate (ST37). For additional information regarding dielectric ratings of materials please refer to Technical Information.

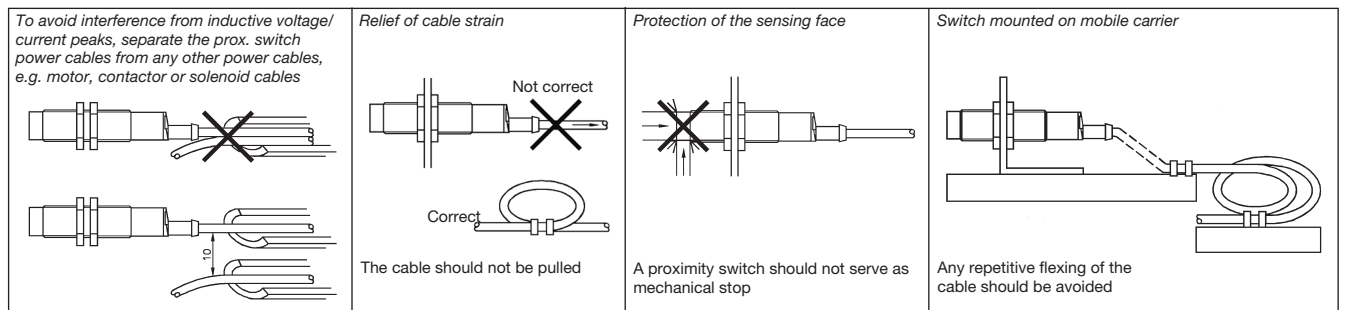

Accessories

- Connector type CONM14NF.. -series.

Delivery Contents

- Capacitive switch: CA12CLC08BP..
- Installation & Adjustment Guide
- 2 x M12 nuts
- **Packaging:** Cardboard box

Teach functions

Normal operation, optimized switching point

1. Mount the sensor in the application without the target present. Yellow LED is not important and green LED is ON.
2. Press the button for 3 seconds until both LEDs are flashing simultaneously. (The background is stored)
3. Place the target in the detection zone.
4. Press the button once and the sensor is ready to operate (green LED ON, yellow LED ON) (The second switch point is stored).
If the target is too close to the background, the sensor will perceive both background and object as background and the LEDs will alternate 3 times.

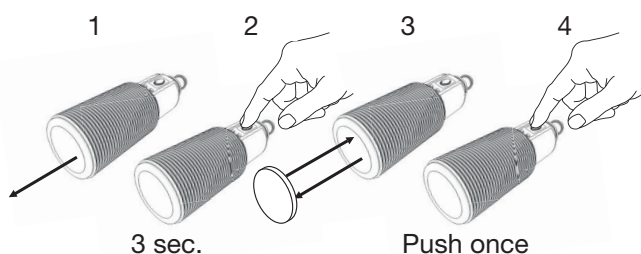

For dynamic set-up (running process)

1. Line up the sensor at the target. Green LED is ON, status on the yellow LED is not important.
2. Press the button for 3 seconds until both LEDs are flashing simultaneously.
3. Press and hold the button a second time for at least one second (both LEDs are flashing simultaneously and fast) and keep the button pressed for at least one process cycle. Release the button and the sensor is ready to operate (the switch point is stored into the sensor and is optimized respecting both background and target information).
A more precise setting is possible if several process cycles are analysed.

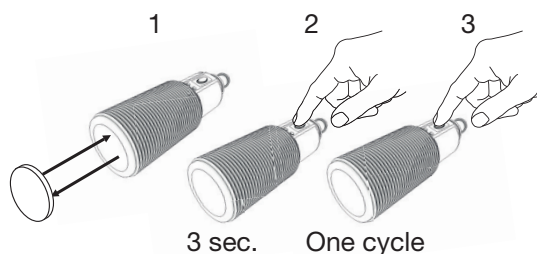

For make or break set-up (N.O. or N.C.)

1. Press the button for 10 seconds, until the green LED flashes.
2. While the green LED flashes, the output is inverted each time the button is pressed. Yellow LED indicates N.O. function selected.
If the button is not pressed within the next 16 seconds, the current output is stored.

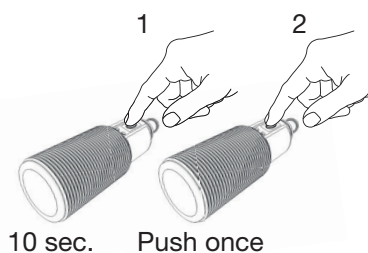

For maximum sensing distance (default setting)

1. Mount the sensor in the application without the target present. Yellow LED is not important and green LED is ON.
2. Press the button for 3 seconds until both LEDs are flashing simultaneously. (The background information is stored)
3. Press the button a second time and the sensor is ready to operate (green LED ON, yellow LED ON) (The sensor is set up with the maximum sensing distance that is not influenced by the background).

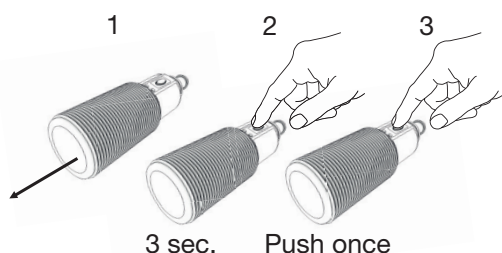

Factory settings

Press the button for 16 sec.