

Transponder-coded safety systems

with external evaluation



EUCHNER
More than safety.

EUCHNER

More than safety.



Headquarters in Leinfelden-Echterdingen



Logistics center in Leinfelden-Echterdingen



Production location in Unterböhringen

Internationally successful – the EUCHNER company

EUCHNER GmbH + Co. KG is a world-leading company in the area of industrial safety technology. EUCHNER has been developing and producing high-quality switching systems for mechanical and systems engineering for more than 60 years.

The medium-sized family-operated company based in Leinfelden, Germany, employs around 750 people around the world.

17 subsidiaries and other sales partners in Germany and abroad work for our international success on the market.

Quality and innovation – the EUCHNER products

A look into the past shows EUCHNER to be a company with a great inventive spirit. We take the technological and ecological challenges of the future as an incentive for extraordinary product developments.

EUCHNER safety switches monitor safety doors on machines and installations, help to minimize dangers and risks and thereby reliably protect people and processes. Today, our products range from electromechanical and electronic components to intelligent integrated safety solutions. Safety for people, machines and products is one of our dominant themes.

We define future safety technology with the highest quality standards and reliable technology. Extraordinary solutions ensure the great satisfaction of our customers. The product ranges are subdivided as follows:

- ▶ Transponder-coded Safety Switches
- ▶ Transponder-coded Safety Switches with guard locking
- ▶ Multifunctional Gate Box MGB
- ▶ Access management systems (Electronic-Key-System EKS)
- ▶ Electromechanical Safety Switches
- ▶ Magnetically coded Safety Switches
- ▶ Enabling Switches
- ▶ Safety Relays
- ▶ Emergency Stop Devices
- ▶ Hand-Held Pendant Stations and Handwheels
- ▶ Safety Switches with AS-Interface
- ▶ Joystick Switches
- ▶ Position Switches



General	4	
Selection criteria	5	
Evaluation units	9	
Read heads	10	
Function expansion	13	
Evaluation units AZ	16	AZ
Evaluation unit CES-AZ-ES-01B	18	
Evaluation unit CES-AZ-ES-02B	20	
Evaluation unit CES-AZ-ES-04B	22	
Field evaluation unit FD	24	FD
Field evaluation unit CES-FD-AP...	26	
Read heads CES	28	CES
Read head CES-A-LNN...	30	
Read head CES-A-LCA... / CES-A-LNA...	32	
Read head CES-A-LQA...	34	
Read head CES-A-LSP...	36	
Read head CES-A-LMN...	38	
Read head CEM	40	CEM
Read head CEM-A-LE05...	42	
Read head CEM-A-LE05H-S2	46	
Read head CEM-A-LH10...	48	
Read head CET	50	CET
Read head CET-AX...	52	
Key adapter CKS	58	CKS
Key adapter CKS	60	
Accessories	62	
Connection material	64	
Bolts	72	
Fixing material	74	
Miscellaneous accessories	76	
Index	78	
Index by item designation	78	
Index by order number	80	

CES technology from the inventor of transponder-coded safety engineering – transponder-coded safety systems from EUCHNER

The transponder-coded safety systems from EUCHNER are modern interlocking devices or guard locking devices of type 4 for the protection of people, machines and processes. They are based on non-contact transponder technology and consist of a coded actuator, a read head and evaluation electronics. In some systems, the read head and evaluation electronics form a self-contained unit. All safety functions are combined in a single component here (internal evaluation). With external evaluation, the actuator is read via a separate read head connected to an evaluation unit in the control cabinet or in the field.

External evaluation

With external evaluation the evaluation electronics for the transponder signals are accommodated in a separate housing. This separation minimizes the read head's size. This is particularly advantageous if the available space at the location to be protected is very limited. All components in this catalog are part of a system with external evaluation

Internal evaluation

Transponder signals are evaluated in the field, not in the control cabinet.

You will find more information on these devices in the catalog for transponder-coded safety switches or at www.euchner.com.

The advantages of transponder-coded safety systems

Transponder-coded safety systems from EUCHNER provide the following advantages:

- Maximum protection against tampering due to uniquely coded actuator
- Highest safety category and Performance Level (PL) according to EN ISO 13849-1
- More tolerance on the door guide

- Less susceptible to vibration and shock
- The actuator can be rotated within the read head's operating distance.
- Insensitive to dirt on the surface
- Can be used in harsh environment
- Suitable for areas with increased hygiene requirements
- Depending on the application, a device with a suitable operating distance can be selected

Type examinations and approvals

EUCHNER is allowed to undertake CE certification for almost all products without the involvement of a notified body, as EUCHNER is allowed to use the system for full quality assurance according to Annex X of the Machinery Directive. This procedure has been confirmed by TÜV Rheinland and is checked regularly. Nevertheless, additional type examinations are undertaken by a notified body such that an independent body again confirms that all laws and standards are met.

Many of the devices listed in this catalog have been tested for instance by the German Social Accident Insurance association (DGUV), formerly the employers' liability insurance association (BG), and are given in the lists from the DGUV.

For countries outside the EU, multiple approvals are necessary for safety products. Many of the products are listed by Underwriters Laboratories (UL) or are marked according to the EurAsian Conformity (EAC) standard.

The approval symbols on the individual pages of the catalog indicate which tests and approvals are available and which body tested the devices. With the aid of the approval symbols listed below you can quickly see which approvals are available for the related device:

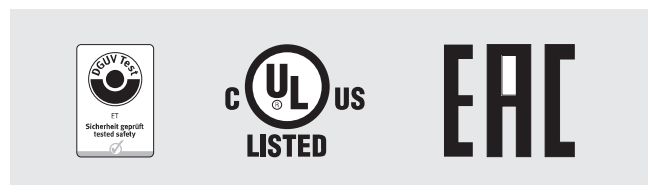

You will find further information on the topic of directives and standards in the Service area at www.euchner.com.

Selection criteria

Evaluation units

Control cabinet evaluation unit CES-AZ

 CES evaluation units combine transponder evaluation with a safety relay in a single device. Depending on version, up to four read heads can be connected. They feature two safety outputs and monitoring outputs for each connected read head, and they also possess connections for a monitored start button and feedback loop. The safety outputs are switched

via relay contacts and permit direct connection of contactors and loads up to 6 A. The devices are each available with unicode and multicode evaluation. The device status can be seen at any time via the indicator LEDs.

Field evaluation unit CES-FD

 This device permits evaluation in the field. The devices are particularly suitable for the connection of safety evaluation units and safety control systems that require short test pulses. The M12 plug connector makes it possible to forward the safety signals directly to an IP 67 field module in a decentral peripheral system, e.g. ET200pro from SIEMENS.

The safe semiconductor outputs have short circuit monitoring and correspond to the standard of the system family AP. The device status can be seen at any time via the indicator LEDs.

Read heads

The read head is fastened to the fixed part of the guard and is connected to the evaluation unit via a two-core screened cable. The actuator fastened to the guard is moved towards the read head by closing the door. When the switch-on distance is reached, power is supplied to the actuator via the read head and the read head transfers the actuator's data to the evaluation unit.

Actuator and read head have a wide operating distance and a broad hysteresis. Misalignment of the door will therefore not result in the system

switching off unintentionally. If the actuator is positioned exactly at the limit of the switch-on distance, vibration at the guard will not cause the machine to stop unintentionally.

EUCHNER provides read heads in a very wide range of designs, with and without guard locking.

Read heads without guard locking (interlocking)

 Interlocking is a feature that ensures a dangerous machine movement cannot be undertaken as long as a guard is open.

For this purpose EUCHNER has read heads that, in combination with the evaluation unit, safely detect whether the actuator is in the operating distance and the guard is closed.

Read heads with guard locking

 Guard locking is a feature that prevents the unintentional opening of a door as long as there is a hazard. For this purpose, EUCHNER has read heads with guard locking in its range. They function like any other CES read head, but also contain a guard locking mechanism.

Different safety levels can be achieved depending on the evaluation unit used. You will find exact information on the level of safety that can be achieved in the combinations tables for each product.

Key adapter CKS

 These devices represent a special type of read head. The CKS does not monitor the door position, but instead detects whether there is a CKS key in the device. This safe key detection can prevent the starting

of hazardous movements if the key is not inserted, for example. The possible applications are very wide ranging.

Coding

Each transponder actuator from EUCHNER features unique coding and significantly surpasses the requirement in EN ISO 14119 for a type 4 switch with high coding level. The code in an actuator cannot be reprogrammed.

Unicode evaluation

With the unicode version, the actuators must be taught-in on the evaluation unit. During the teach-in operation, the actuator code is assigned to the evaluation unit. This code is saved in the evaluation unit. Whenever an actuator is read, the evaluation unit compares the code just read with the last code saved. Only if the two bit patterns are identical is the actuator detected and the enable paths are closed. The number of possible teach-in operations is dependent of the evaluation unit used. Only the last actuator taught in is detected. Unicode detection provides a high level of protection against tampering.

Fixcode evaluation

With fixcode devices, the teach-in operation is performed at EUCHNER prior to delivery. An actuator is permanently assigned to the device in this process. The device can be operated only with this one actuator. No additional actuators can be taught in.

Multicode evaluation

Unlike systems with unique code detection, with multicode evaluation a specific actuator code is not requested, instead it is only checked whether the actuator is of a suitable type that can be detected by the system (multicode detection). There is no exact comparison of the actuator code with a code saved in the evaluation unit. As a result a teach-in operation for the actuator is not necessary.

Operating distance and active face

The operating distances indicate the distance between the actuator and sensor from which a switching process is triggered. The active faces on the actuator and read head define these distances. The faces must be parallel to each other on approach.

The transponder field

Transponder-coded systems operate using electromagnetic fields. These fields differ depending on the design of the device.

Approach directions

Dependent on the housing design, the devices have one or more active faces and therefore one or more possible approach directions.

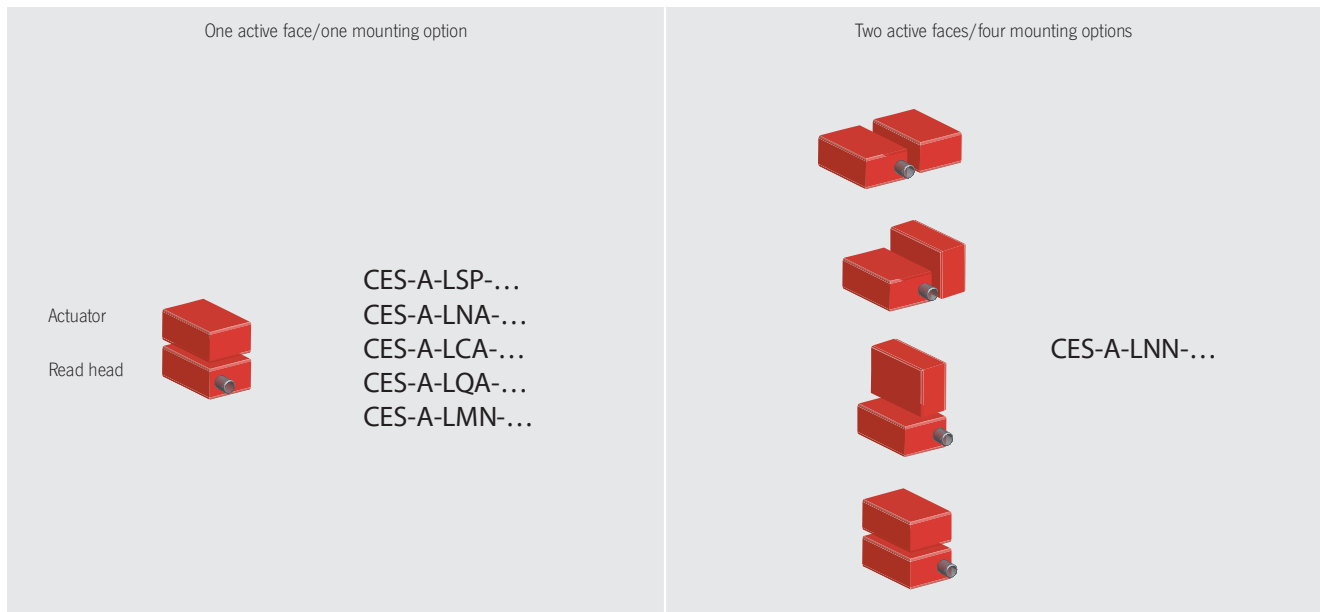

The transponder field

Transponder-coded systems operate using electromagnetic fields. These fields differ depending on the design of the device.

Switch-on distance, switch-off distance and hysteresis

On moving an actuator toward a switch, a switching signal is triggered on reaching the switch-on distance. The actuator is detected and the safety outputs are switched on.

If the actuator is removed again from the field, the safety outputs are switched off again on reaching the switch-off distance. As the switch-on distance and switch-off distance are different, there is a switching hysteresis. The larger the switching hysteresis, the less sensitive the system is to vibration.

Typical operating distance

Each system has typical and assured operating distances. The assured operating distances are defined in the EN 60947-5-3 standard and are briefly explained in the following.

The information in the catalog corresponds to the typical operating distance.

Assured operating distance s_{ao}

According to EN 60947-5-3, the assured operating distance is the distance from the active sensor face within which the presence of the actuator is correctly detected under all defined environmental conditions and manufacturing tolerances.

Assured switch-off distance s_{ar}

According to EN 60947-5-3, the assured switch-off distance is the distance from the active sensor face outside which the actuator is no longer detected under any environmental conditions, manufacturing tolerances and fault conditions, so that the system switches off.

Limit-range indication

The device detects if the actuator wanders out of the operating distance and indicates that the actuator is in the limit range by flashing the STATE LED. This allows the safety door to be readjusted in time.

Side lobes

Transponder fields in general comprise a main field and secondary fields (so-called side lobes). The secondary fields are significantly smaller than the main field and are to the side of the main field. A transponder is also read if it is in a secondary field. This effect is undesirable and on the very close, side approach of an actuator causes problems because the actuator is read before it has reached the main field (and therefore the intended position).

Surrounding material and installation depth

The operating distance is reduced by flush, recessed installation in the surrounding material. This effect is stronger with a metallic surrounding material than with plastic, for example. Completely encapsulated installation in metal in which the active face on the transponder is covered is in general not possible, as the field is attenuated excessively.

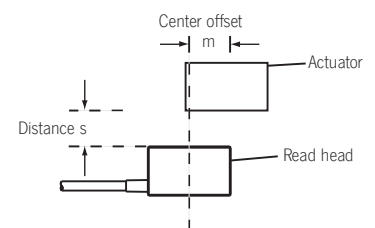
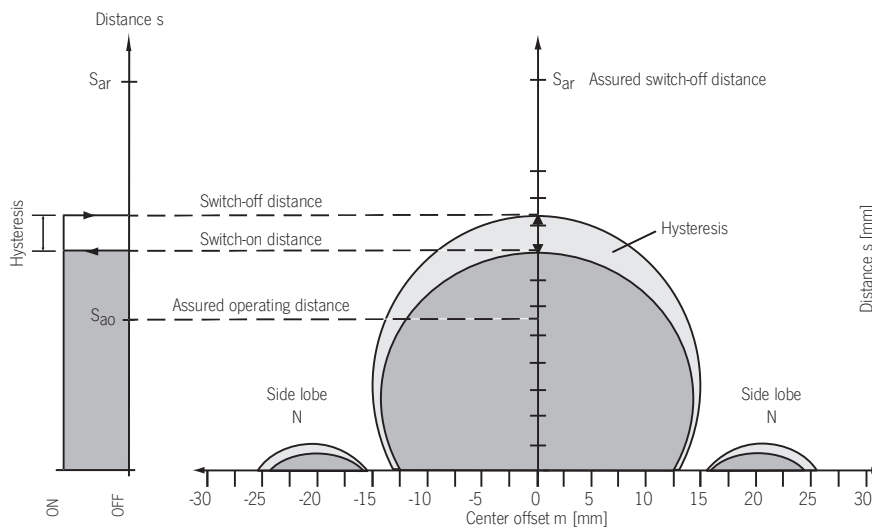

Guard locking type

Process protection or personnel protection?

As per EN ISO 14119, guard locking for personnel protection requires continuous monitoring of the guard locking function. On opening or failure of the guard locking, the safety outputs must be switched off.

Any guard locking for personnel protection can also be used as guard locking for process protection.

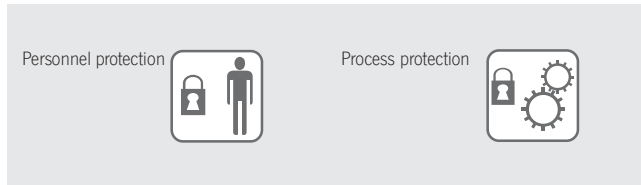

Guard locking for process protection is not monitored. The safety function of these devices is limited to position monitoring for the safety door. Monitoring the guard locking state is not part of the safety function.

Principle of operation of guard locking

EUCHNER offers two guard locking methods:

■ Electromechanical guard locking

Here a guard locking pin is moved, which prevents the removal of the actuator (form locking).

■ Magnetic guard locking

Here the actuator is held in place by the magnetic attraction force on the guard locking solenoid (force locking).

Guard locking principle

EUCHNER offers two guard locking principles:

Guard locking method	Closed-circuit current principle	Open-circuit current principle
Electromechanical guard locking	Guard locking actuated by spring force applied and power-ON released	Guard locking actuated by power-ON applied and spring released
Magnetic guard locking		Guard locking actuated by power-ON applied and released by power-OFF applied

Evaluation units

CES-AZ

- ▶ Evaluation of signals in the control cabinet
- ▶ Versions for the connection of one, two or four read heads
- ▶ Integrated safety relay
- ▶ Two relay safety outputs (relay contacts)
- ▶ PL e/category 4 according to EN ISO 13849-1
- ▶ Available in the unicode and multicode variants



CES-FD

- ▶ Evaluation of signals in the field
- ▶ Connection of a CES read head or a CKS key adapter via plug connector
- ▶ Familiar EUCHNER AP interface
- ▶ Direct connection to IP 67 field modules for various decentral peripheral systems
- ▶ PL e/category 4 according to EN ISO 13849-1
- ▶ Available in the unicode and multicode variants



Read heads without guard locking

CES-A-LNN

- ▶ Cube-shaped design 42 x 25 mm
- ▶ Two active faces
- ▶ LED for the indication of the door position
- ▶ Degree of protection IP 67
- ▶ M8 plug connector/connecting cable

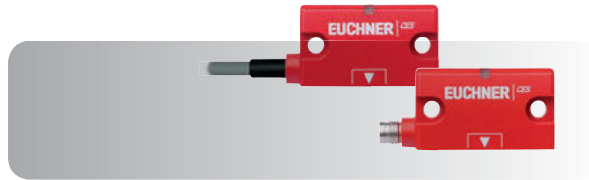

CES-A-LNA/CES-A-LNC

- ▶ Cube-shaped design 42 x 25 mm
- ▶ One active face
- ▶ Degree of protection IP 67/IP 69/IP 69K
- ▶ Version with increased resilience to aggressive media
- ▶ M8 plug connector/connecting cable

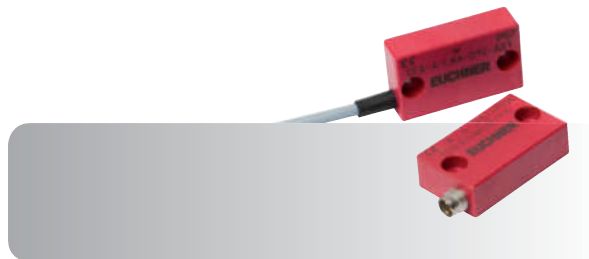

CES-A-LQA

- ▶ Square design 50 x 50 mm
- ▶ One active face
- ▶ Large tolerance for center offset
- ▶ Degree of protection IP 67
- ▶ M8 plug connector



CES-A-LSP

- ▶ Very flat design
- ▶ Optimized for profile mounting
- ▶ One active face
- ▶ LED for the indication of the door position
- ▶ Degree of protection IP 67
- ▶ M5 plug connector/connecting cable



CES-A-LMN

- ▶ Cylindrical design M12
- ▶ One active face
- ▶ Suitable for pressure ranges up to 10 bar
- ▶ Large temperature range
- ▶ Degree of protection IP 67/IP 69/IP 69K
- ▶ M8 plug connector



Read heads with guard locking

CEM-A

- ▶ Magnetic guard locking for process protection
- ▶ Locking force 650 N or 1,000 N
- ▶ Version with adjustable adhesive force (acts with guard locking inactive)
- ▶ Degree of protection IP 67
- ▶ LED indicator (voltage at solenoid)



CET-AX

- ▶ Guard locking for personnel protection according to EN 14119
- ▶ Very high locking force up to 6,500 N
- ▶ Head can be rotated in 90° steps
- ▶ Actuator guide with large freedom of movement
- ▶ Metal housing
- ▶ Degree of protection IP 67
- ▶ LED indicator (guard locking position)
- ▶ M8/M12 plug connector



Key Adapter CKS

CKS

- ▶ Key adapter with integrated CES read head
- ▶ Safe detection of the CKS key in the key adapter
- ▶ M8 plug connector
- ▶ For installation in control panel



Function expansion

Due to the large selection of accessories and parts that can be retrofitted, additional or expanded functions are possible. You will find an overview of the accessories available in the section of the catalog on the related device.

Release functions

Some situations require guard locking to be released manually (e.g. malfunctions or an emergency). The following release functions are available for EUCHNER devices:

Auxiliary release and mechanical key release (1)

Option for manual guard locking release using a tool or key from outside danger area in the event of a malfunction.

Escape release (2)

Option for manual guard locking release to leave the danger area from the escape side (danger area) without tools.

Emergency unlocking (3)

Option for manual guard locking release without tools from the access side (outside the danger area) in case of danger. The emergency unlocking mechanism must be returned to the locked state manually.



Lockout bar

The lockout bar can be used to prevent maintenance personnel from being unintentionally locked in the danger area, for example. In locked position, the lockout bar prevents activation of guard locking. The lockout bar can be secured in locked position using padlocks.

A removable lockout bar that blocks the switch head or the actuator is available for this purpose.



Versatile accessories

Bolts

Bolts function as follows: the bolt tongue mechanically guides the actuator when it is inserted into the safety switch actuating head. The bolt mounted on the door frame comprises a protruding bolt tongue, the handle and the actuator, mounted offset somewhat to the rear. The switch bracket with the safety switch is fitted to the frame. The bolt absorbs forces that act on the read head and the actuator and that could damage the read head and actuator.

There are bolts for many safety switches from EUCHNER. Some as a set with pre-assembled read head and actuator.

Function expansions that can be retrofitted

For some devices there are function expansions that can be retrofitted, e.g. manual releases, cover plates, lockout bars and much more. You can find suitable accessories for your device very simply at www.euchner.com.

Connection material

EUCHNER offers a large selection of connecting cables, plug connectors and other connection accessories. You can find suitable accessories for your device very simply at www.euchner.com.

Installation material

EUCHNER offers mounting plates and brackets for many devices for a wide variety of fastening situations. You can find suitable accessories for your device very simply at www.euchner.com.

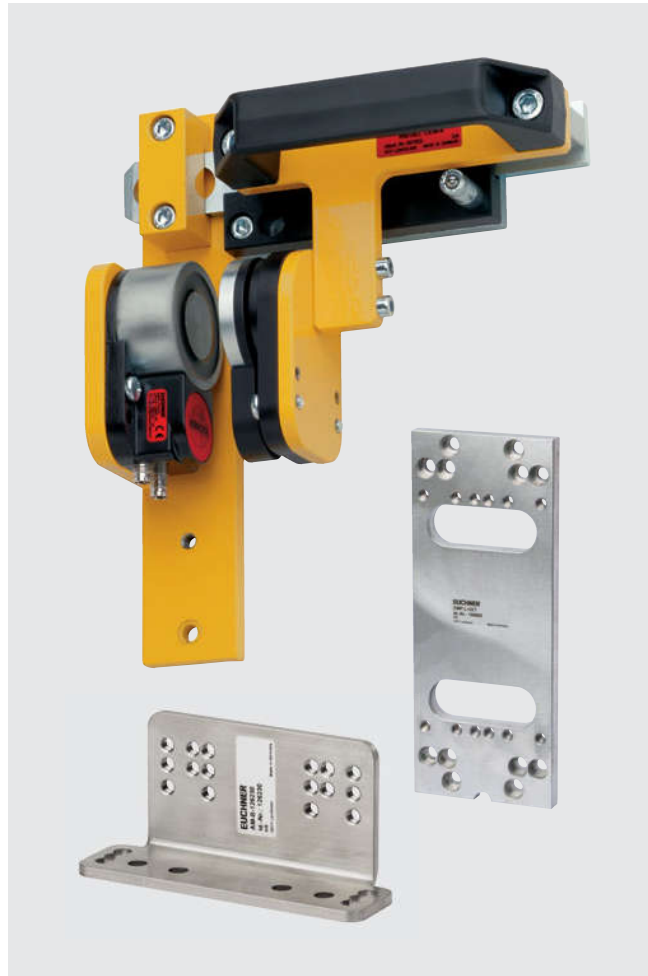

“Evaluation and safety relay in one device – cost-effective solution for up to four safety doors.”

- ▶ Evaluation of transponder signals in the control cabinet
- ▶ Up to four read heads can be connected
- ▶ Two pairs of safe relay contacts
- ▶ Start button and feedback loop can be connected
- ▶ Plug-in connection terminals
- ▶ PL e/category 4 according to EN ISO 13849-1



CES
CET
CEM
CKS



Evaluation unit CES-AZ-.ES-01B



- ▶ One read head can be connected
- ▶ Two safety outputs (relay contacts with two internally connected NO contacts per output)
- ▶ Start button and feedback loop can be connected
- ▶ Plug-in connection terminals

Details

Available coding options

- ▶ Unicode evaluation
- ▶ Multicode evaluation

Guard lock monitoring

Evaluation units in the series CES-AZ also make it possible to use read heads with integrated guard locking for personnel protection during overtraveling machine movements. For suitable read heads, please refer to the ordering table below.

Category according to EN ISO 13849-1

Due to two redundant safety paths (relay contacts) with two internal, monitored normally open contacts per safety path, suitable for:

- ▶ PL e/category 4 according to EN ISO 13849-1

Each safety path is independently safe.

LED indicator

STATE	Status LED
DIA	Diagnostics LED
OUT	Safety output status

Additional connections

TST	Input for self-test
O1	Monitoring output (semiconductor)
DIA	Diagnostics output
Y1, Y2	Feedback loop
S	Start button connection (monitoring of the falling edge)

Notice

- ▶ The plug-in connection terminals are not included and must be ordered separately.

Further information

- ▶ Dimension drawings see p. 19
- ▶ Accessories and spare parts see p. 19
- ▶ For detailed information, enter the order number for the product in the search box at www.euchner.com.





Ordering table

Evaluation unit

Series	Version	Order no./item	
CES-AZ-AES-01B Unicode	<p>p-switching</p>	104770 CES-AZ-AES-01B	For detailed information, enter the order number for the product in the search box at www.euchner.com .
CES-AZ-UES-01B Multicode		105139 CES-AZ-UES-01B	
Connection kits for evaluation unit CES-AZ-...-01B	Plug-in screw terminals	104756 CES-EA-TC-AK04-104756	
	Plug-in spring terminals	112631 CES-EA-TC-KK04-112631	

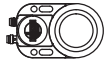
Read heads

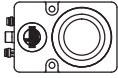
Series	Design	Guard locking	Typ. switch-on distance [mm]	
CES-A-LNN-...		–	15	Page 30
		–	15	
CES-A-LNA-...		–	15	Page 32
		–	15	
CES-A-LCA-...		–	15	Page 32
CES-A-LQA-...		–	23	Page 34
CES-A-LSP-...		–	20	Page 36
		–	20	
CES-A-LMN-...		–	5	Page 38
CKS-A-...		–	–	Page 60

Series	Design	Guard locking	Typ. switch-on distance [mm]	
CEM-A-...			-	Page 42
				
CET-AX-...			-	Page 52

Accessories

Type	Version	
PM-SCL Inrush current limiting module	For CES evaluation units	Page 71

Dimension drawing

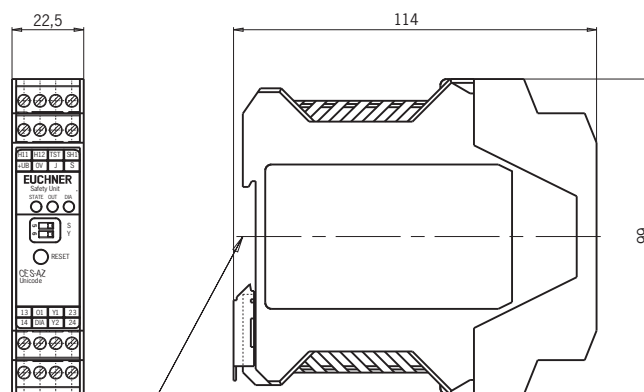

— Suitable for 35 mm mounting rail according to EN 60715

Block diagram

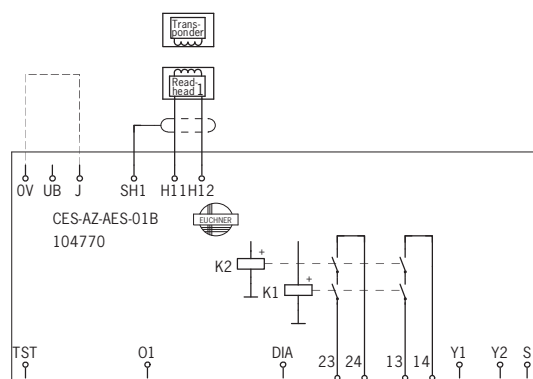

Evaluation unit CES-AZ-.ES-02B



- ▶ Two read heads can be connected
- ▶ Two safety outputs (relay contacts with two internally connected NO contacts per output)
- ▶ Start button and feedback loop can be connected
- ▶ Plug-in connection terminals

Details

Available coding options

- ▶ Unicode evaluation
- ▶ Multicode evaluation

Guard lock monitoring

Evaluation units in the series CES-AZ also make it possible to use read heads with integrated guard locking for personnel protection during overtraveling machine movements. For suitable read heads, please refer to the ordering table below.

Category according to EN ISO 13849-1

Due to two redundant safety paths (relay contacts) with two internal, monitored normally open contacts per safety path, suitable for:

- ▶ PL e/category 4 according to EN ISO 13849-1

Each safety path is independently safe.

LED indicator

STATE Status LED
DIA Diagnostics LED
OUT Safety output status

Additional connections

TST Input for self-test
O1, O2 Monitoring outputs (semiconductor)
DIA Diagnostic output
Y1, Y2 Feedback loop
S Start button connection (monitoring of the falling edge)

Notice

- ▶ The plug-in connection terminals are not included and must be ordered separately.

Further information

- ▶ Dimension drawings see p. 21
- ▶ Accessories and spare parts see p. 21
- ▶ For detailed information, enter the order number for the product in the search box at www.euchner.com.





Ordering table

Evaluation unit

Series	Version	Order no./item	
CES-AZ-AES-02B Unicode	 p-switching	104775 CES-AZ-AES-02B	For detailed information, enter the order number for the product in the search box at www.euchner.com .
CES-AZ-UES-02B Multicode		105140 CES-AZ-UES-02B	
Connection kits for evaluation unit CES-AZ-...-02B	Plug-in screw terminals	104771 CES-EA-TC-AK06-104771	
	Plug-in spring terminals	112630 CES-EA-TC-KK06-112630	

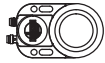
Read heads

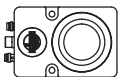
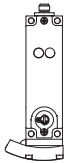
Series	Design	Guard locking	Typ. switch-on distance [mm]	
CES-A-LNN-...		-	15	Page 30
		-	15	
CES-A-LNA-...		-	15	Page 32
		-	15	
CES-A-LCA-...		-	15	Page 32
CES-A-LQA-...		-	23	Page 34
CES-A-LSP-...		-	20	Page 36
		-	20	
CES-A-LMN-...		-	5	Page 38
CKS-A-...		-	-	Page 60

Series	Design	Guard locking	Typ. switch-on distance [mm]	
CEM-A-...			-	Page 42
				
CET-AX-...			-	Page 52

Accessories

Type	Version	
PM-SCL Inrush current limiting module	For CES evaluation units	Page 71

Dimension drawing

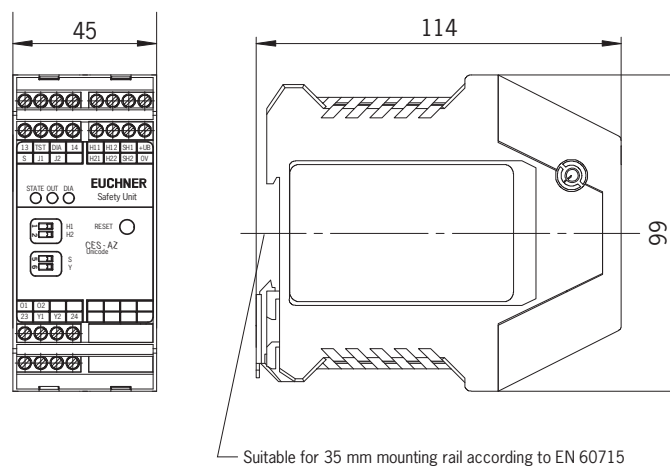

Block diagram

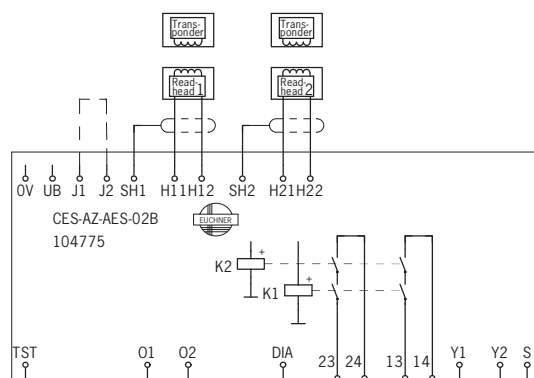

Evaluation unit CES-AZ-.ES-04B



- ▶ **Four read heads can be connected**
- ▶ **Two safety outputs (relay contacts with two internally connected NO contacts per output)**
- ▶ **Start button and feedback loop can be connected**
- ▶ **Plug-in connection terminals**

Details

Available coding options

- ▶ Unicode evaluation
- ▶ Multicode evaluation

Guard lock monitoring

Evaluation units in the series CES-AZ also make it possible to use read heads with integrated guard locking for personnel protection during overtraveling machine movements. For suitable read heads, please refer to the ordering table below.

Category according to EN ISO 13849-1

Due to two redundant safety paths (relay contacts) with two internal, monitored normally open contacts per safety path, suitable for:

- ▶ PL e/category 4 according to EN ISO 13849-1

Each safety path is independently safe.

LED indicator

STATE Status LED
DIA Diagnostics LED
OUT Safety output status

Additional connections

TST Input for self-test
O1...O4 Monitoring outputs (semiconductor)
DIA Diagnostic output
Y1, Y2 Feedback loop
S Start button connection (monitoring of the falling edge)

Notice

- ▶ The plug-in connection terminals are not included and must be ordered separately.

Further information

- ▶ Dimension drawings see p. 23
- ▶ Accessories and spare parts see p. 23
- ▶ For detailed information, enter the order number for the product in the search box at www.euchner.com.

Ordering table





Evaluation unit

Series	Version	Order no./item	
CES-AZ-AES-04B Unicode	Monitoring outputs p-switching	104780 CES-AZ-AES-04B	For detailed information, enter the order number for the product in the search box at www.euchner.com .
CES-AZ-ALS-04B Unicode	Monitoring outputs n-switching	113090 ¹⁾ CES-AZ-ALS-04B	
CES-AZ-UES-04B Multicode	Monitoring outputs p-switching	105141 CES-AZ-UES-04B	
Connection kits for evaluation unit CES-AZ-...-04B	Plug-in screw terminals	104776 CES-EA-TC-AK08-104776	
	Plug-in spring terminals	112629 CES-EA-TC-KK08-112629	

1) No UL or German Social Accident Insurance approval

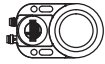
Read heads

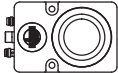
Series	Design	Guard locking	Typ. switch-on distance [mm]	
CES-A-LNN-...		–	15	Page 30
		–	15	
CES-A-LNA-...		–	15	Page 32
		–	15	
CES-A-LCA-...		–	15	Page 32
CES-A-LQA-...		–	23	Page 34
CES-A-LSP-...		–	20	Page 36
		–		
CES-A-LMN-...		–	5	Page 38
CKS-A-...		–	–	Page 60

Series	Design	Guard locking	Typ. switch-on distance [mm]	
CEM-A-...			-	Page 42
				
CET-AX-...			-	Page 52

Accessories

Type	Version	
PM-SCL Inrush current limiting module	For CES evaluation units	Page 71

Dimension drawing

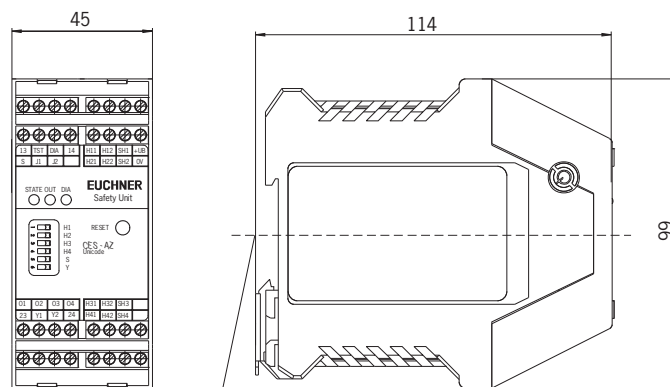

Suitable for 35 mm mounting rail according to EN 60715

Block diagram

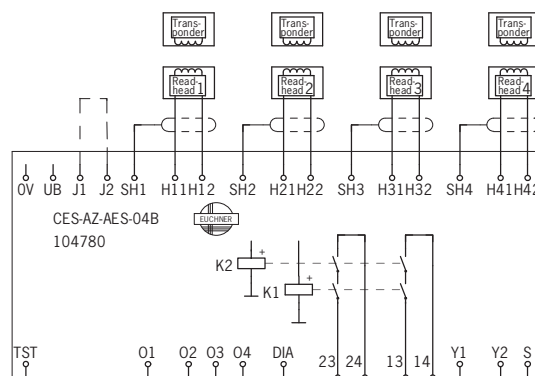

“Evaluation and forwarding of the signals to the control system directly in the field – ideal for field-based connection concepts.”

.....

- ▶ Evaluation of transponder signals in the field
- ▶ For one read head
- ▶ Direct connection to IP 67 field modules for various decentral peripheral systems
- ▶ Two safe semiconductor outputs (EUCHNER system family AP)
- ▶ Minimal wiring effort
- ▶ Own pulsing for short circuit detection
- ▶ Small space requirement
- ▶ PL e/category 4 according to EN ISO 13849-1



CES
CKS



Field evaluation unit CES-FD-AP-...



- ▶ Connection of a CES read head or a CKS key adapter
- ▶ Evaluation of signals in the field
- ▶ Connection to the ET200s and ET200pro
- ▶ Familiar EUCHNER AP interface
- ▶ Limit-range indication

Details

Available coding options

- ▶ Unicode evaluation
- ▶ Multicode evaluation

Short circuit monitoring

The switch generates its own clock signal on the output lines FO1A/FO1B.

Pay attention to this aspect when connecting to control systems and relays.

Category according to EN ISO 13849-1

Due to two redundantly designed semiconductor outputs (safety outputs) with internal monitoring suitable for:

- ▶ PL e/category 4 according to EN ISO 13849-1

LED indicator

STATE Status LED
DIA Diagnostics LED

Further information

- ▶ Dimension drawings see p. 27
- ▶ Accessories and spare parts see p. 26
- ▶ For detailed information, enter the order number for the product in the search box at www.euchner.com.

Ordering table

Field evaluation unit

Series	Version		Order no./item	
CES-FD-AP-U-01-... Unicode	A	B	119865 CES-FD-AP-U-01-UI-119865	For detailed information, enter the order number for the product in the search box at www.euchner.com .
CES-FD-AP-M-01-... Multicode	M12 5 pin	M8 3 pin	115534 CES-FD-AP-M-01-UI-115534	

Read heads

Series	Design	Guard locking	Typ. switch-on distance [mm]	
CES-A-LMN-...		-	5	Page 38
CKS-A-...		-	-	Page 60

Accessories

Type	Version		
Connection material	Connecting cable with plug connector	M12 5 pin	Page 68
	Extension for read head connection	M8 3 pin	Page 65

M12

5 pin

M8

3 pin

FD

Dimension drawing

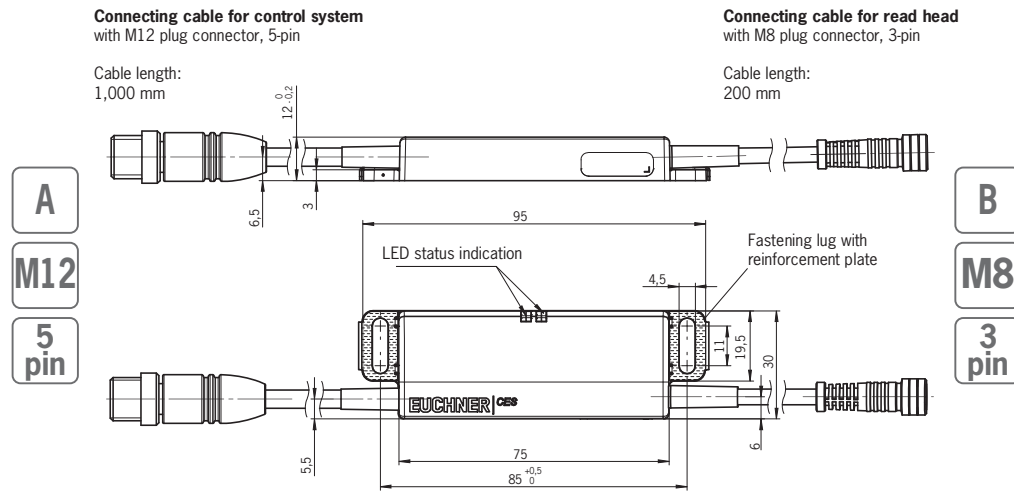

Terminal assignment

A M12 5 pin	Pin	Designation	Function	Wire color
	Without monitoring output (pin 5 not used)			
	1	UB	Power supply DC 24 V	BN
	2	FO1A	Safety output, channel 1	WH
	3	0V	Ground DC 0 V	BU
	4	FO1B	Safety output, channel 2	BK
	-	-	-	GY

B M8 3 pin	Pin	Designation	Function	Wire color
		-		
	1	H1	Data line	BN
	2	H2	Data line	WH
	3	SH	Shield	-

“Large selection of read heads – find the right sensor for every purpose.”

- ▶ Read heads optimized for special applications
- ▶ Evaluation of different actuator designs
- ▶ Numerous combination options
- ▶ Various operating distances
- ▶ With either plug connector or fixed connecting cable
- ▶ LED for the indication of the door position (depending on version)

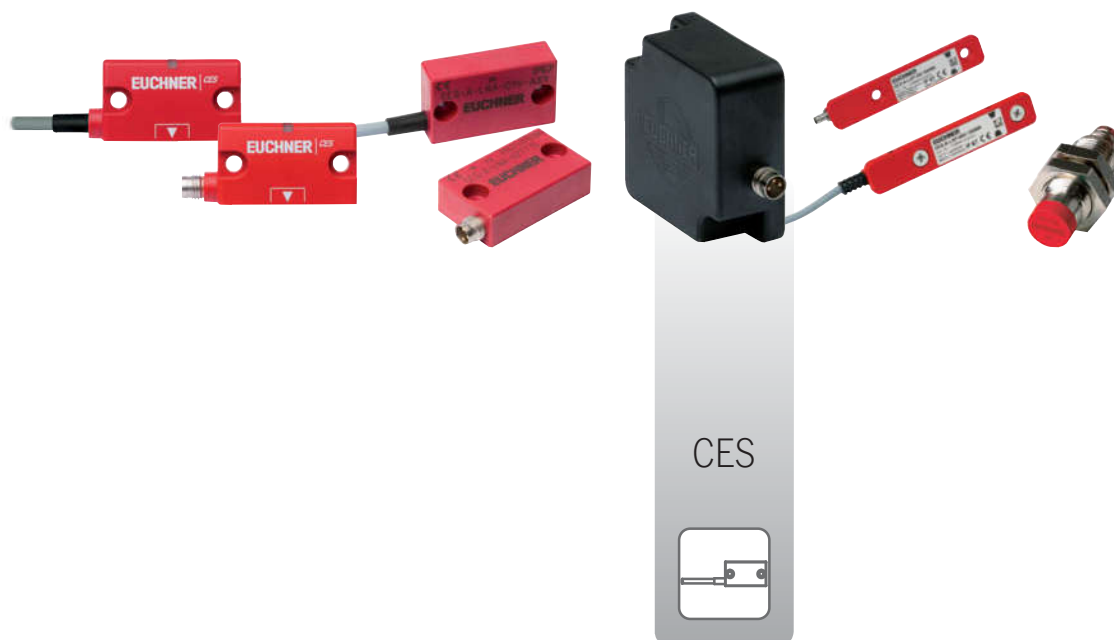

Read head CES-A-LNN-...



Details

Combination options

See ordering table below.

Notice

▶ Actuators must be ordered separately!

Further information

- ▶ Dimension drawings see p. 31
- ▶ Accessories and spare parts see p. 30
- ▶ For detailed information, enter the order number for the product in the search box at www.euchner.com.

- ▶ Cube-shaped design 42 x 25 mm
- ▶ Attachment compatible with series CES-A-LNA/LCA
- ▶ LED for the indication of the door position
- ▶ Two active faces

Ordering table

Read head

Series	Version	Order no./item	
CES-A-LNN-...	42 x 25	5m CES-A-LNN-05V-106602	For detailed information, enter the order number for the product in the search box at www.euchner.com .
		10m CES-A-LNN-10V-113294	
		25m CES-A-LNN-25V-115107	
	M8 3 pin CES-A-LNN-SC-106601		
	42 x 25		

Actuator

Series	Design	Typ. switch-on distance [mm]	Order no./item	
CES-A-BBN	42 x 25	15	106600 CES-A-BBN-106600	For detailed information, enter the order number for the product in the search box at www.euchner.com .
CES-A-BDN	Ø6 x 26	19	104730 CES-A-BDN-06-104730	

Accessories

Type	Version	
Connection material	Connecting cable with plug connector 	M8 3 pin
Fixing material	Safety screws	Page 76



3 pin

M8

3 pin

Dimension drawing

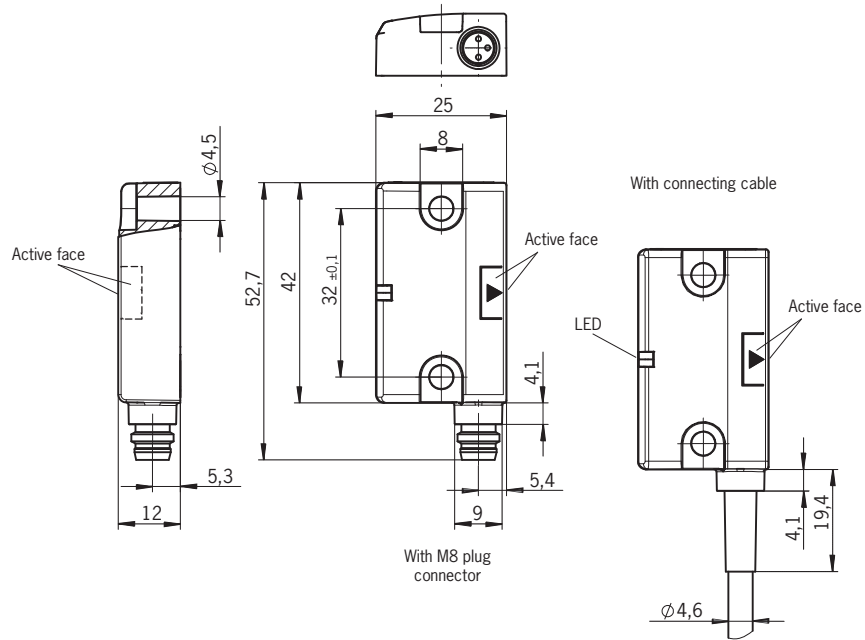

Terminal assignment

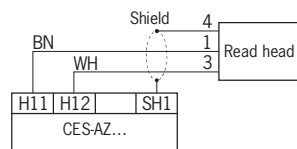

Read head CES-A-LCA-.../CES-A-LNA-...



Details

Combination options

See ordering table below.

Notice

▶ Actuators must be ordered separately!

Further information

- ▶ Dimension drawings see p. 33
- ▶ Accessories and spare parts see p. 33
- ▶ For detailed information, enter the order number for the product in the search box at www.euchner.com.

- ▶ Cube-shaped design 42 x 25 mm
- ▶ Version with plug connector suitable for snap-action and screw terminals
- ▶ One active face

Ordering table

Read head

Series	Version	Order no./item		
CES-A-LCA-...	42 x 25 Material: PE-HD ¹⁾	10m PVC	For detailed information, enter the order number for the product in the search box at www.euchner.com .	
	CES-A-LNA-...	42 x 25		5m
10m				071846 CES-A-LNA-10V
PVC 15m				071847 CES-A-LNA-15V
25m				071975 CES-A-LNA-25V
5m				077806 CES-A-LNA-05P
10m				077807 CES-A-LNA-10P
PUR 15m				084682 CES-A-LNA-15P
42 x 25				M8 3 pin

1) Suitable for use in aggressive media (e.g. acids, alkalines)



3 pin

M8

3 pin

Actuator

Series	Design	Typ. switch-on distance [mm]	Order no./item	
CES-A-BCA	42 x 25 Material: PE-HD ¹⁾	15	088786 CES-A-BCA	For detailed information, enter the order number for the product in the search box at www.euchner.com .
CES-A-BBA	42 x 25		071840 CES-A-BBA	
CES-A-BDA	Ø20	16	084720 CES-A-BDA-20	
CES-A-BDA-18	Ø18	16	156935 CES-A-BDA-18	

1) Suitable for use in aggressive media (e.g. acids, alkalines)

Accessories

Type	Version	
Connection material	Connecting cable with plug connector 	M8 3 pin Page 65
Bolts	Bolts for read head CES-A-LNA... 	Page 72
Fixing material	Safety screws	Page 76

Dimension drawing

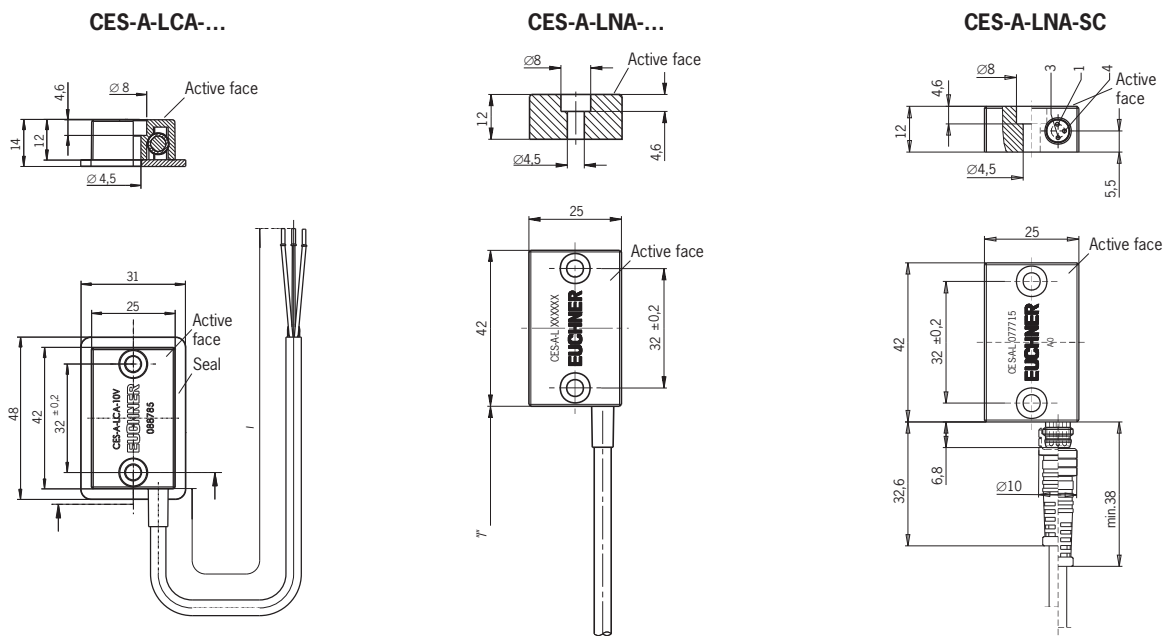

Terminal assignment

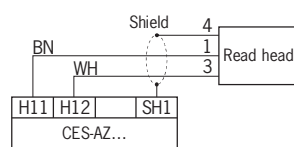

Read head CES-A-LQA-...



Details

Combination options

See ordering table below.

Notice

▶ Actuators must be ordered separately!

Further information

- ▶ Dimension drawings see p. 35
- ▶ Accessories and spare parts see p. 34
- ▶ For detailed information, enter the order number for the product in the search box at www.euchner.com.

- ▶ Cube-shaped design 50 x 50 mm
- ▶ M8 plug connector (snap-action and screw terminals)
- ▶ Large tolerance for center offset
- ▶ One active face

Ordering table

Read head

Series	Version		Order no./item	
CES-A-LQA-...	50 x 50	M8 3 pin	095650 CES-A-LQA-SC	For detailed information, enter the order number for the product in the search box at www.euchner.com .

Actuator

Series	Design	Typ. switch-on distance [mm]	Order no./item	
CES-A-BQA	50 x 50	23	098108 CES-A-BQA	For detailed information, enter the order number for the product in the search box at www.euchner.com .
CES-A-BBA	42 x 25	15	071840 CES-A-BBA	

Accessories

Type	Version		
Connection material	Connecting cable with plug connector 	M8 3 pin	Page 65
Fixing material	Safety screws		Page 76

Dimension drawing

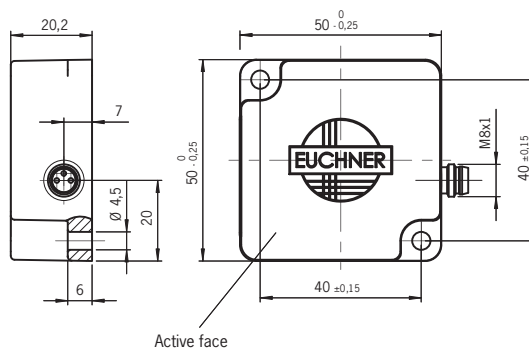

Terminal assignment

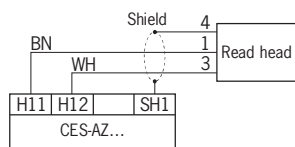

Read head CES-A-LSP-...



Details

Combination options

See ordering table below.

Notice

Actuators must be ordered separately!

Further information

- ▶ Dimension drawings see p. 37
- ▶ Accessories and spare parts see p. 36
- ▶ For detailed information, enter the order number for the product in the search box at www.euchner.com.

- ▶ Optimized for aluminum profile mounting
- ▶ LED for the indication of the door position
- ▶ One active face

Ordering table

Read head

Series	Version	Order no./item	
CES-A-LSP-...	97 x 18	104966 CES-A-LSP-05V-104966	For detailed information, enter the order number for the product in the search box at www.euchner.com .
		104967 CES-A-LSP-10V-104967	
	97 x 18	104969 CES-A-LSP-SB-104969	

Actuator

Series	Design	Typ. switch-on distance [mm]	Order no./item	
CES-A-BSP	97 x 18	20	104970 CES-A-BSP-104970	For detailed information, enter the order number for the product in the search box at www.euchner.com .

Accessories

Type	Version	
Connection material	Connecting cable with plug connector 	Page 64
Installation material	Clamping pieces for mounting on aluminum profiles	Page 75



3 pin

M5

4 pin

CES

Dimension drawing

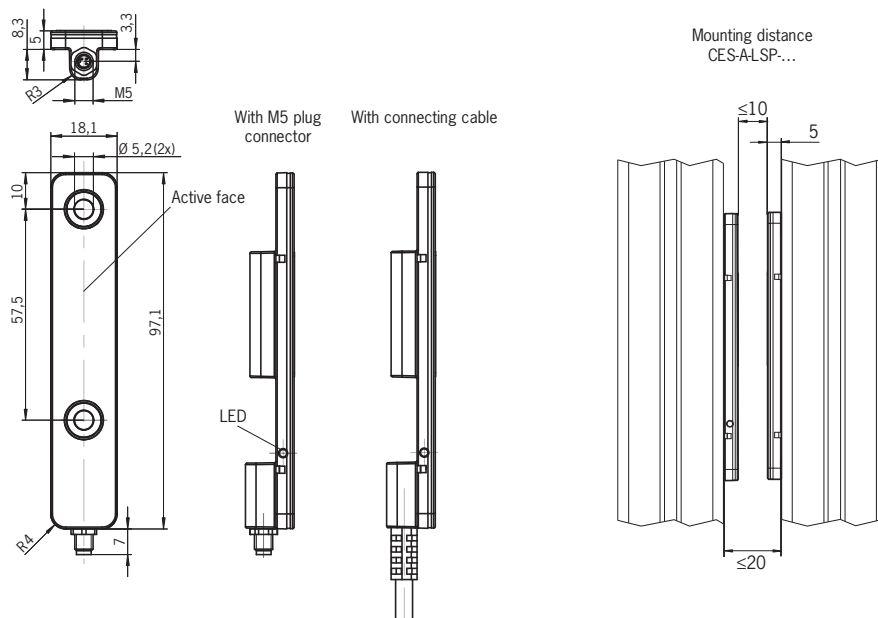

Terminal assignment

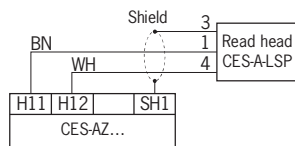

Read head CES-A-LMN-...



Details

Combination options

See ordering table below.

Notice

▶ Actuators must be ordered separately!

Further information

- ▶ Dimension drawings see p. 39
- ▶ Accessories and spare parts see p. 38
- ▶ For detailed information, enter the order number for the product in the search box at www.euchner.com.

- ▶ Cylindrical design M12
- ▶ M8 plug connector (snap-action and screw terminals)
- ▶ One active face

Ordering table

Read head

Series	Version	Order no./item	
CES-A-LMN-...	M12 x 1 M8 3 pin	077790 CES-A-LMN-SC	For detailed information, enter the order number for the product in the search box at www.euchner.com .

Actuator

Series	Design	Typ. switch-on distance [mm]	Order no./item	
CES-A-BMB	M12 x 0.75	5	077791 CES-A-BMB	For detailed information, enter the order number for the product in the search box at www.euchner.com .

Accessories

Type	Version	
Connection material	Connecting cable with plug connector M8 3 pin	Page 65

Dimension drawing

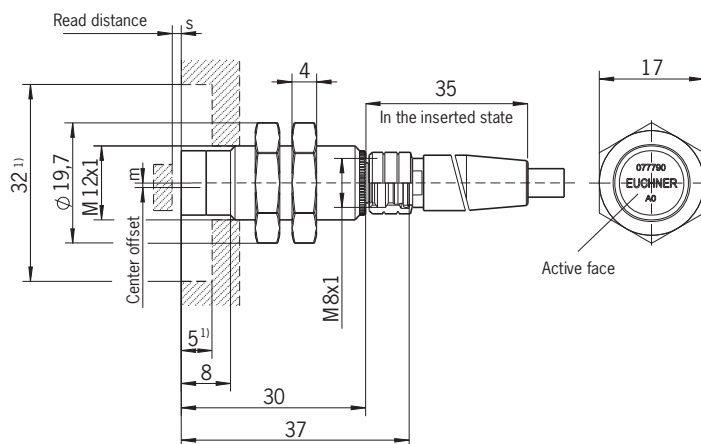

1) Metal-free zone

Terminal assignment

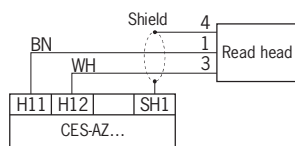

“Unmonitored magnetic guard locking for process protection.”

- ▶ Very rugged construction
- ▶ Guard locking and door stop in one
- ▶ Locking force 650 N or 1,000 N (depending on version)
- ▶ Adjustable adhesive force (depending on version)
- ▶ With and without remanence (depending on version)
- ▶ Spring-mounted anchor plate for the actuator
- ▶ LED for the indication of the door position (depending on version)

Read
Head

CEM



CEM



CEM

Read head CEM-A-LE05...
with unmonitored guard locking for process protection



- ▶ Read head with guard locking without guard lock monitoring
- ▶ Locking force 650 N
- ▶ With and without remanence

Details

Without remanence

Read heads without remanence are de-magnetized when the solenoid is switched off. As a consequence soiling due to adhering metal chips is reduced.

For this purpose the operating voltage U_B must always be applied.

Further information

- ▶ Dimension drawings see p. 43
- ▶ Accessories and spare parts see p. 43
- ▶ For detailed information, enter the order number for the product in the search box at www.euchner.com.

Ordering table

Read head

Series	Version	Order no./item	
CEM-A-LE05...	50 x 80	With remanence 094800 CEM-A-LE05K-S2	For detailed information, enter the order number for the product in the search box at www.euchner.com .
		Without remanence 095792 CEM-A-LE05R-S2	



Actuator

Series	Design	Order no./item	
CEM-A-BE05	50 x 80	094805 CEM-A-BE05	For detailed information, enter the order number for the product in the search box at www.euchner.com .

Solenoid (without read head)

Series	Design	Order no./item	
CEM-A-ME05K	50 x 80	109755 CEM-A-ME05K-S1-109755	For detailed information, enter the order number for the product in the search box at www.euchner.com .

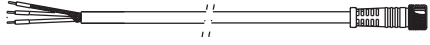
Accessories

Type	Version	
Connection material	Connecting cable with plug connector 	M8 3 pin Page 65
		M8 4 pin Page 66
Bolts	Bolts for read heads CEM	Page 72
Fixing material	Mounting plates 	Page 74
	Safety screws for actuators	Page 76
Miscellaneous accessories	Lockout bar CEM (mounting on the actuator CEM-A-BE05) 	Page 77

Dimension drawing

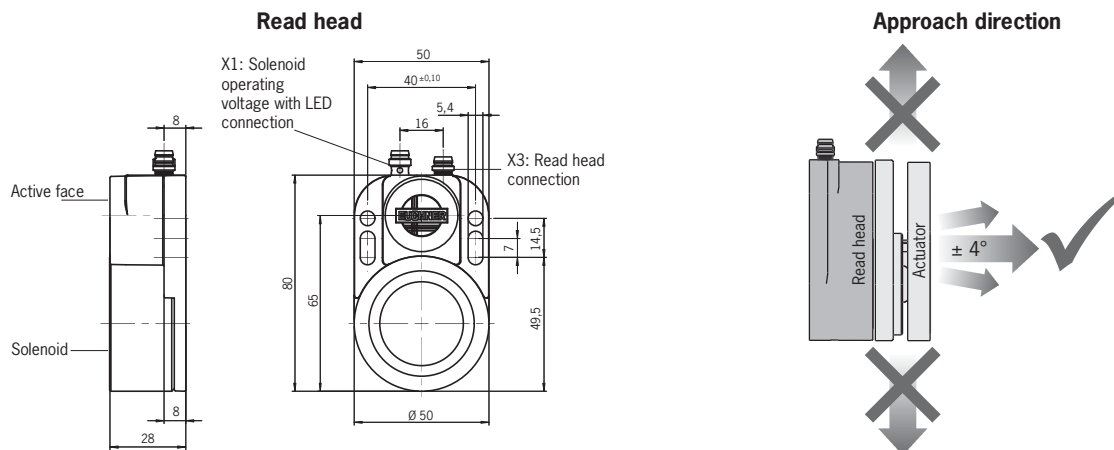

M8

3 pin

M8

4 pin

Terminal assignment

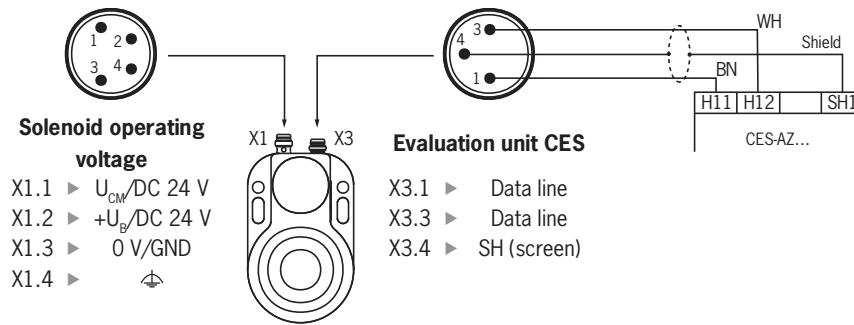

CEM-ALE05K-S2
CEM-A-ME05K-S1-109755

CEM-ALE05R-S2

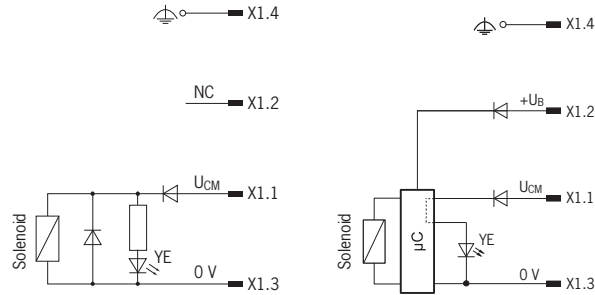

Circuit diagram for connection of solenoid operating voltage, plug X1
A free-wheeling diode is already integrated into each CEM

Read head CEM-A-LE05H-S2
with unmonitored guard locking for process protection



- ▶ Read head with guard locking without guard lock monitoring
- ▶ Locking force 650 N
- ▶ Adjustable adhesive force

Details

Adjustable adhesive force

This version has an adhesive force also with the guard locking switched off. In this way it is intended, for example, to prevent the safety door from opening due to vibration or similar. The adhesive force can be adjusted using a programming adapter to 70 N, 110 N (factory setting) or 150 N.

Further information

- ▶ Dimension drawings see p. 47
- ▶ Accessories and spare parts see p. 46
- ▶ For detailed information, enter the order number for the product in the search box at www.euchner.com.

Ordering table

Read head

Series	Version	Order no./item	
CEM-A-LE05...	50 x 80 With adjustable adhesive force (factory setting: 110 N)	104606 CEM-A-LE05H-S2	For detailed information, enter the order number for the product in the search box at www.euchner.com .
CEM-A-ZPS-110013	Programming adapter for setting the adhesive force	110013 CEM-A-ZPS-110013	

Actuator

Series	Design	Order no./item	
CEM-A-BE05	50 x 80	094805 CEM-A-BE05	For detailed information, enter the order number for the product in the search box at www.euchner.com .

Accessories

Type	Version	
Connection material	Connecting cable with plug connector 	M8 3 pin Page 65
		M8 4 pin Page 66
Bolts	Bolts for read heads CEM	Page 72
Fixing material	Mounting plates 	Page 74
	Safety screws for actuators	Page 76
Miscellaneous accessories	Lockout bar CEM (mounting on the actuator CEM-A-BE05) 	Page 77

M8

3 pin

M8

4 pin

Dimension drawing

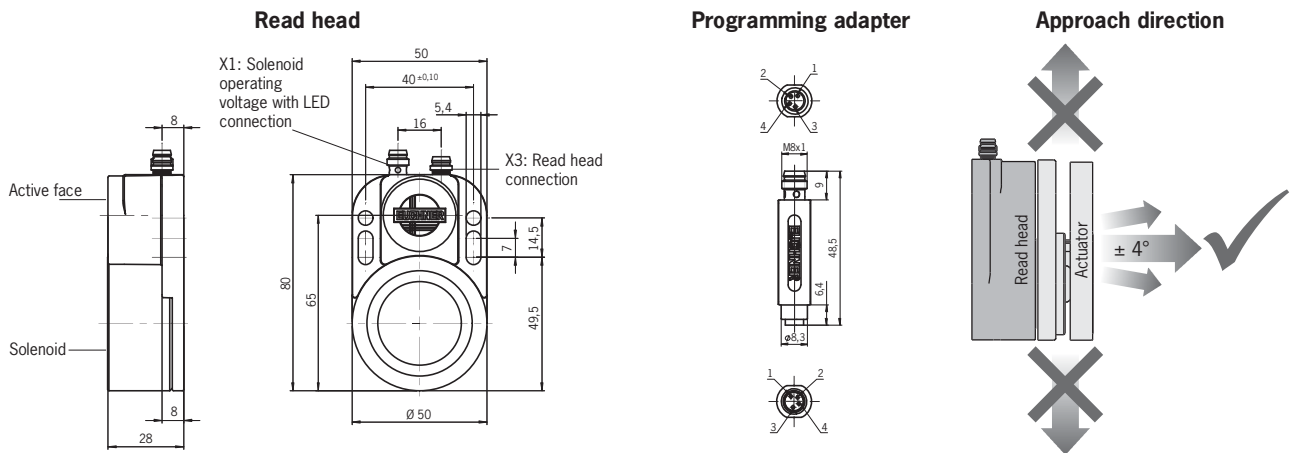

Terminal assignment

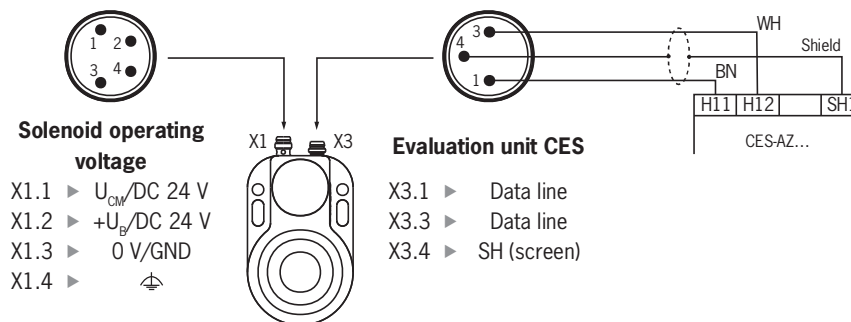

CEM-A-LE05H-S2

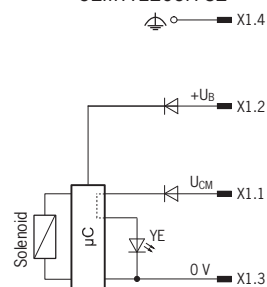

Circuit diagram for connection of solenoid operating voltage, plug X1
A free-wheeling diode is already integrated into each CEM

Read head CEM-A-LH10...
with unmonitored guard locking for process protection



- ▶ Read head with guard locking without guard lock monitoring
- ▶ Locking force 1,000 N
- ▶ With and without remanence

Details

Without remanence

Read heads without remanence are de-magnetized when the solenoid is switched off. As a consequence soiling due to adhering metal chips is reduced.

For this purpose the operating voltage U_B must always be applied.

Further information

- ▶ Dimension drawings see p. 49
- ▶ Accessories and spare parts see p. 48
- ▶ For detailed information, enter the order number for the product in the search box at www.euchner.com.

Ordering table

Read head

Series	Version		Order no./item	
CEM-A-LH10...		65 x 95	With remanence 095170 CEM-A-LH10K-S3	For detailed information, enter the order number for the product in the search box at www.euchner.com .
			Without remanence 095793 CEM-A-LH10R-S3	

Actuator

Series	Design	Order no./item	
CEM-A-BH10		65 x 95 095175 CEM-A-BH10	For detailed information, enter the order number for the product in the search box at www.euchner.com .

Accessories

Type	Version	
Connection material	Connecting cable with plug connector 	M8 3 pin Page 65
	Connecting cable with male plug for LED indicator 	M8 4 pin Page 66
		M8 4 pin Page 67
Fixing material	Safety screws for actuators	Page 76

M8

3 pin

M8

4 pin

Dimension drawing

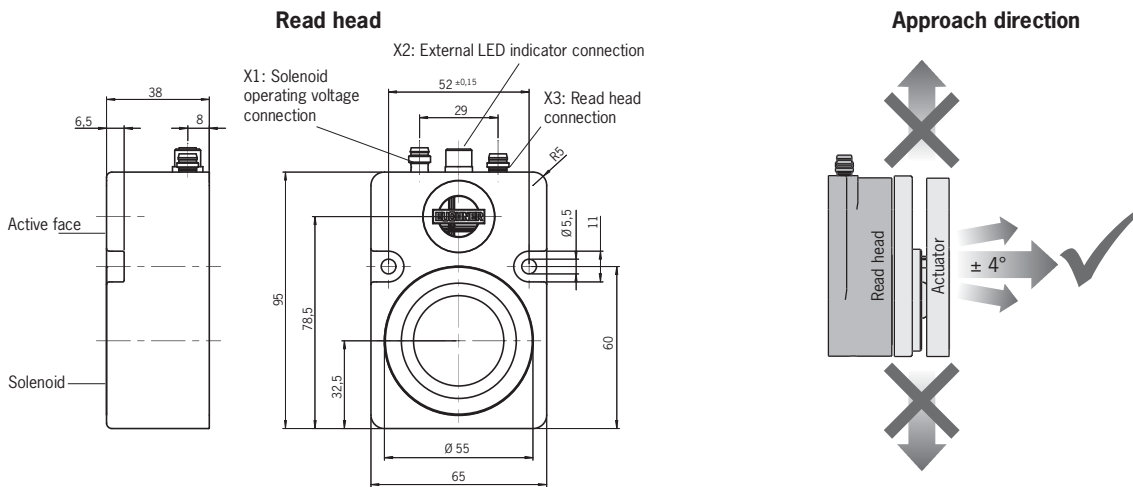

Terminal assignment

External LED indicator connection

- X2.1 ▶ LED + X2.3 ▶ LED 0 V
- X2.2 ▶ - X2.4 ▶ -

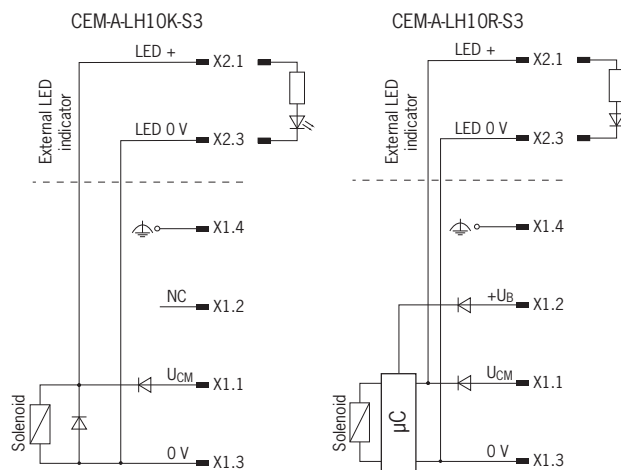
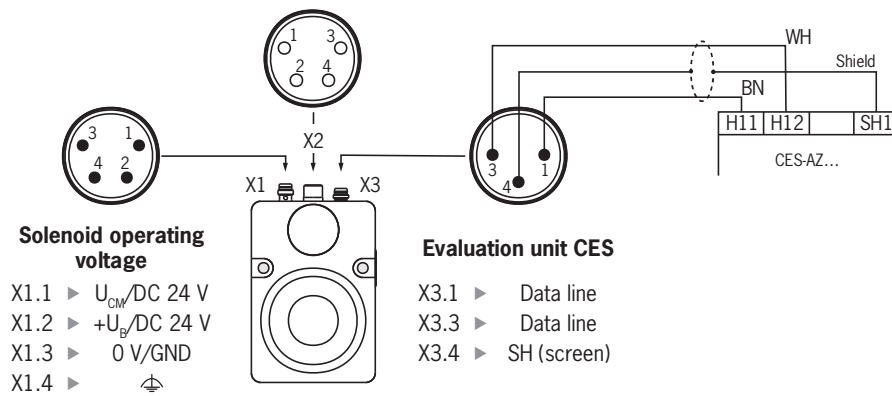

Circuit diagram for connection of solenoid operating voltage, plug S1
A free-wheeling diode is already integrated into each CEM

“Guard locking for personnel protection.”

- ▶ Locking force 6,500 N
- ▶ Robust metal housing
- ▶ No precise door adjustment necessary
- ▶ Two LED indicators

Read
Head

CET



CET

Read head CET.-AX-... with guard locking for personnel protection



- ▶ Read head with guard locking and guard lock monitoring
- ▶ Locking force up to 6,500 N
- ▶ Dual-channel control of the guard locking solenoid possible

Notice

Actuators must be ordered separately!

Details

Approach direction



Head can be rotated in 90° steps

Category according to EN ISO 13849-1

The category is dependent on the installation position:

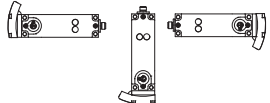
Installation position	Category/PL
	Cat. 3 PLe
	Cat. 4 PLe

Guard locking types

CET1 Closed-circuit current principle

Guard locking by spring force. Release by applying voltage to the guard locking solenoid.

CET2 Open-circuit current principle

Guard locking by applying voltage to the guard locking solenoid. Release by spring force.

Auxiliary release

Included with all versions as standard.

Escape release (optional)

Some devices have an escape release (see ordering table).

The escape release can be extended by 30/50/80 mm when the accessory AF-E-80-127377 is used.

Lockout bar (optional)

The lockout bar can be used to prevent maintenance personnel from being unintentionally locked in the danger area, for example. In locked position, the lockout bar prevents activation of guard locking. The lockout bar can be secured in locked position with up to three locks.

Double ramp



Versions with double ramp can be approached from two sides.



Devices with double ramp are also suitable for applications in which the switch must be "passed over." E.g. on doors that can be opened inwards and outwards.

The double ramp can be retrofitted (see accessories page 77).

LED indicator

LED red see wiring diagram









LED green see wiring diagram

Further information

- ▶ Dimension drawings see p. 55
- ▶ Accessories and spare parts see p. 54
- ▶ For detailed information, enter the order number for the product in the search box at www.euchner.com.

Ordering table







CET-AX-...-SA/SE/SF-... with plug connector M12

 Order no./item	Ramp	Escape release	Two LEDs (one freely configurable)	Two LEDs (two freely configurable)	For wiring diagram see page 56
CET1 Closed-circuit current principle					
095735 CET1-AX-LRA-00-50X-SA		75 mm	•		
102161 CET1-AX-LRA-00-50F-SA			•		
104051 ¹⁾ CET1-AX-LRA-00-50X-SF			•		
104062 CET1-AX-LRA-00-50L-SA				•	
100399 CET1-AX-LDA-00-50X-SE			•		
103750 CET1-AX-LDA-00-50F-SA		75 mm	•		
CET2 Open-circuit current principle					
106039 ²⁾ CET2-AX-LRA-00-50X-SA			•		

1) Plug connector can be rotated by 360°



2) No German Social Accident Insurance or UL approval

CET-AX-...-SC with two plug connectors M8









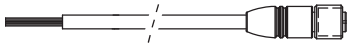
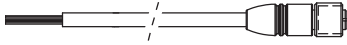

 Order no./item	Ramp	Escape release	Two LEDs (one freely configurable)	Two LEDs (two freely configurable)	For wiring diagram see page 56
CET1 Closed-circuit current principle					
102988 CET1-AX-LRA-00-50X-SC			•		
103444 CET1-AX-LDA-00-50X-SC			•		
CET2 Open-circuit current principle					
109932 ¹⁾ CET2-AX-LRA-00-50X-SC			•		

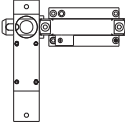
1) No German Social Accident Insurance or UL approval

Actuator

Series	Design	Order no./item	
CET-A-BWK-50X		096327 CETA-BWK-50X	For detailed information, enter the order number for the product in the search box at www.euchner.com .

Accessories

Type	Version	
Connection material	Connecting cable with plug connector 	M8 3 pin Page 65
	Connecting cable with plug connector 	M8 4 pin Page 66
	Connecting cable with plug connector 	M12 8 pin Page 69
Bolts	Bolts for housing design CET 	Page 73
Fixing material	Mounting plates 	Page 74
	Safety screws for actuators	Page 76
Miscellaneous accessories	Lockout bar 	Page 77
	Mechanical key release 	
	Emergency unlocking 	
	Cover 	
	Double ramp 	
	Extension for escape release 	

Dimension drawing

M12

With plug connector M12

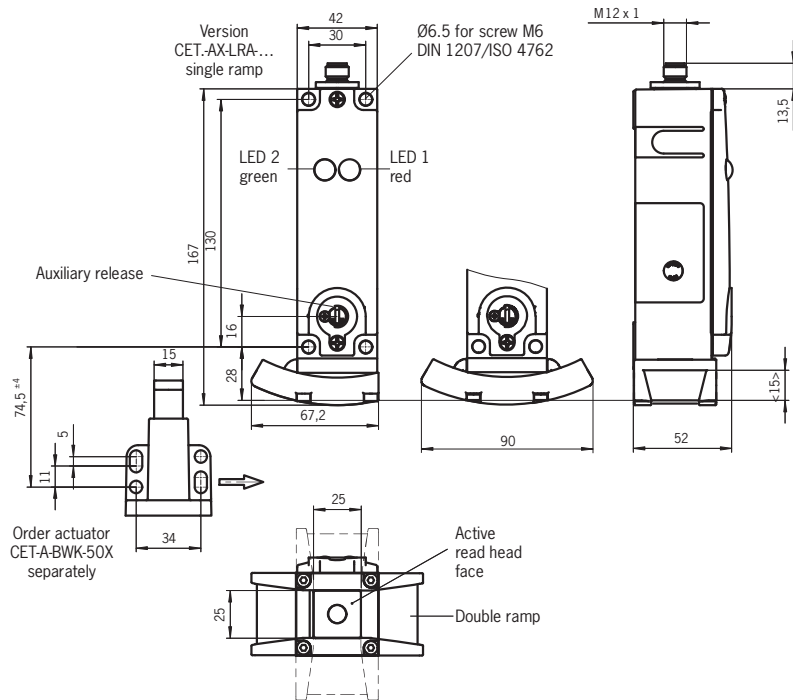

**2x
M8**

With two plug connectors M8

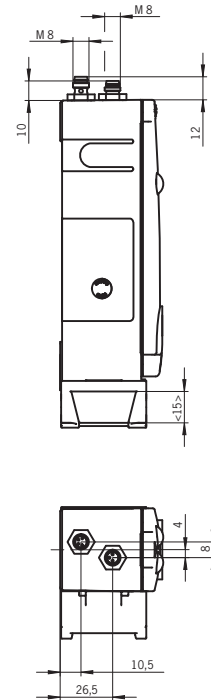

With escape release

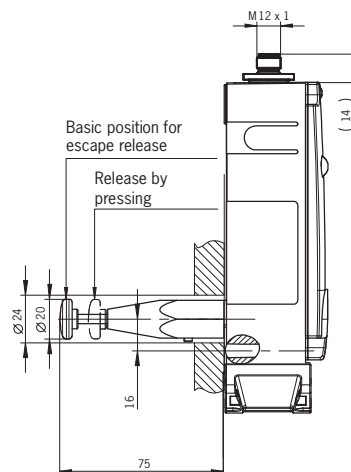

M12

8 pin

2x M8

3 pin

4 pin

Terminal assignment

A

B

M12

Wiring diagrams A and B

Pin	Designation	Function	M12	
			A	B
1	H1	Read head data line	●	●
2	H2	Read head data line	●	●
3	SH	Data line screen	●	●
4	LED 2	Freely configurable, 24 V	●	●
5	0V LED 2	0V LED 2	●	
	LED 1	Freely configurable, 24 V		●
6	UCM	Operating voltage of guard locking solenoid, DC 24 V	●	●
7	0 V/GND	Operating voltage of guard locking solenoid, DC 0 V	●	
		Operating voltage of guard locking solenoid and LED 1, DC 0 V		●
8	Housing	Housing	●	●

C

2x M8

Wiring diagram C

Pin	Designation	Function
X 1.1	H1	Read head data line
X 1.3	H2	Read head data line
X 1.4	SH	Data line screen
X 2.1	UCM	Operating voltage of guard locking solenoid, DC 24 V / LED 1
X 2.2	0V LED 2	0V LED 2
X 2.3	0 V/GND	Operating voltage of guard locking solenoid and LED 1, DC 0 V
X 2.4	LED 2	Freely configurable, 24 V

“Key adapter CKS – safe entry into installations.”

- ▶ **Key inserted / key removed** states are reliably detected
- ▶ LED for status indication
- ▶ Varied use, e.g. as a lockout bar, authorization for selecting operating modes, key transfer system, etc.
- ▶ PL e/category 4 according to EN ISO 13849-1

Key
Adapter

CKS



CKS

Key adapter CKS



- ▶ Key adapter with integrated CES read head
- ▶ LED indicator
- ▶ Simple connection via M8 plug connector
- ▶ High degree of protection IP 67
- ▶ Inserted key is held by spring clip

Details

Combination options

Connection to evaluation unit CES / CES-FD required. See actuator ordering table below.

Important: Key adapter CKS must not be used as a lockout bar in combination with multicode evaluation.

Notice

The key is not included with the key adapter and must be ordered separately.

Further information

- ▶ Dimension drawings see p. 61
- ▶ Accessories and spare parts see p. 60
- ▶ For detailed information, enter the order number for the product in the search box at www.euchner.com.

Ordering table

Key adapter

Series	Version	Order no./item	
CKS-A-...	M8 3 pin	113130 CKS-A-L1B-SC-113130	For detailed information, enter the order number for the product in the search box at www.euchner.com .

Key

Series	Design	Order no./item	
CKS-A-RD-113461		113461 CKS-A-BK1-RD-113461	For detailed information, enter the order number for the product in the search box at www.euchner.com .

Accessories

Type	Version	
Connection material	Connecting cable with plug connector M8 3 pin	Page 65

M8 3 pin

CKS

Dimension drawing

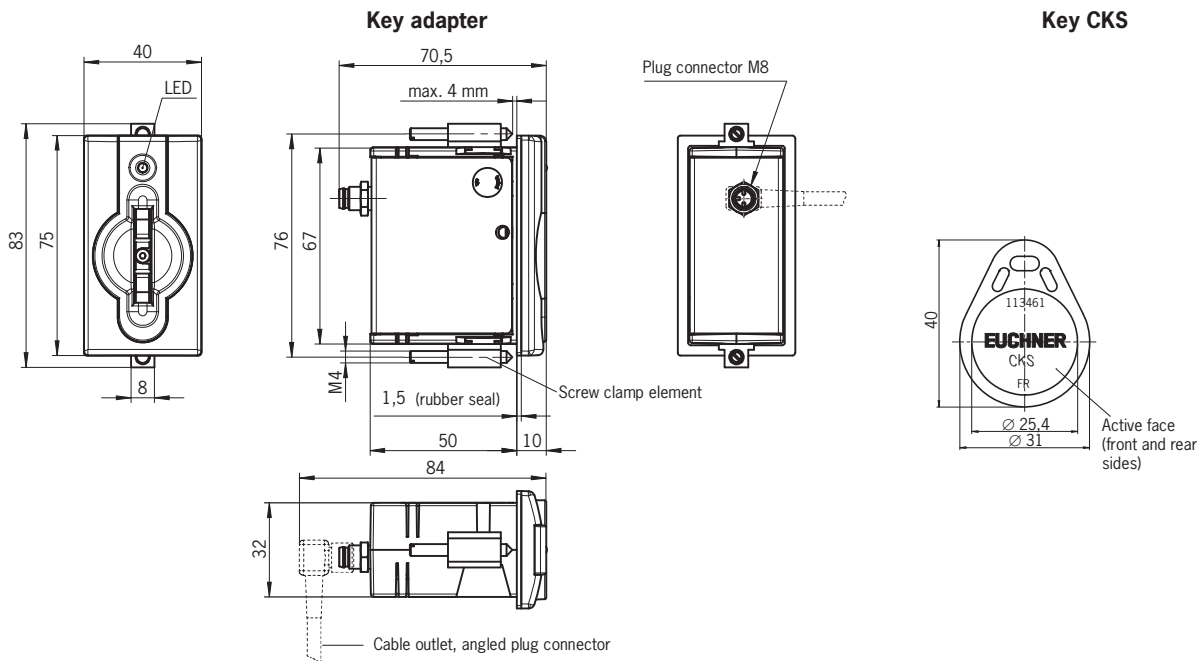

Terminal assignment

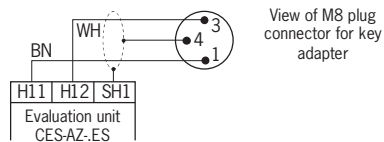

“Exploit all the advantages –
with well thought-out
original accessories from
EUCHNER.”

- ▶ Connection material – connect safely and easily; no long search for cables and plug connectors.
- ▶ Fixing material – safe and easy installation for many installation situations.
- ▶ Bolts and bolt sets – door handle and mounting plate in one.
Complete sets comprising bolt and read head as complete solution.
- ▶ Function expansions – increase the possible applications with additional functions such as releases, lockout bars, etc.

Accessories

Connection material

M5 4 pin PVC

Connecting cables with plug connector

For the connection of:

CES-ALSP-..SB



Version		Order no./item	
<div style="display: flex; flex-direction: column; align-items: center;"> <div style="border: 1px solid black; border-radius: 5px; padding: 2px; margin-bottom: 5px;">M5</div> <div style="border: 1px solid black; border-radius: 5px; padding: 2px; margin-bottom: 5px;">4 pin</div> <div style="border: 1px solid black; border-radius: 5px; padding: 2px;">PVC</div> </div> <div style="text-align: center; margin-top: 10px;"> </div>	5m	<p>105555 C-M05F04-02X014PV05,0-ES-105555</p>	<p>For detailed information, enter the order number for the product in the search box at www.euchner.com.</p>
	10m	<p>105556 C-M05F04-02X014PV10,0-ES-105556</p>	
	20m	<p>105559 C-M05F04-02X014PV20,0-ES-105559</p>	

Connecting cables with plug connector

For the connection of:

CES-FD-AP-...

CES-AL-...-SC

CEM-AL-...

CET-AX-...-SC

CKS-AL-...-SC

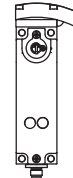

Version		Order no./item	
<p>M8 3 pin PVC</p> <p>Connecting cable with female plug, flying lead, 2 x 0.25 mm², screened</p>	3m	077935 C-M08F03-02X025PV03,0-ES-077935	<p>For detailed information, enter the order number for the product in the search box at www.euchner.com.</p>
	5m	077793 C-M08F03-02X025PV05,0-ES-077793	
	10m	077767 C-M08F03-02X025PV10,0-ES-077767	
	20m	077716 C-M08F03-02X025PV20,0-ES-077716	
	25m	077717 C-M08F03-02X025PV25,0-ES-077717	
<p>Connecting cable with female plug, flying lead, 2 x 0.25 mm², screened</p>	10m	084701 C-M08F03-02X025PV10,0-ES-084701	
	25m	099998 C-M08F03-02X025PV25,0-ES-099998	
<p>Extension for read head cable</p>	0,4m	115464 C-M08M03-02X025PU0,4-M08F03-115464	
	5m	084762 C-M08F03-02X025PU05,0-ES-084762	
<p>M8 3 pin PUR</p> <p>Connecting cable with female plug, flying lead, 2 x 0.25 mm², screened</p>	10m	084763 C-M08F03-02X025PU10,0-ES-084763	
	15m	084764 C-M08F03-02X025PU15,0-ES-084764	
	20m	084765 C-M08F03-02X025PU20,0-ES-084765	
	25m	084766 C-M08F03-02X025PU25,0-ES-084766	
<p>Connecting cable with female plug, flying lead, 2 x 0.25 mm², screened</p>	10m	098590 C-M08F03-02X025PU10,0-ES-098590	
	25m	120280 C-M08F03-02X025PU25,0-ES-120280	

M8 4 pin PVC PUR

Connecting cables with plug connector

For solenoid operating voltage, read heads

For the connection of:

CEM-A-L...

CET.AX-...-SC

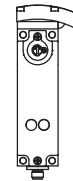

Version	Order no./item	
<p>M8 4 pin PVC</p> <p>Connecting cable with female plug, flying lead, 4 x 0.25 mm²</p>	2m	088812 C-M08F04-04X025PV02,0-ES-088812
	5m	088813 C-M08F04-04X025PV05,0-ES-088813
	10m	088814 C-M08F04-04X025PV10,0-ES-088814
	15m	088815 C-M08F04-04X025PV15,0-ES-088815
	25m	095035 C-M08F04-04X025PV25,0-ES-095035
<p>Connecting cable with female plug, flying lead, 4 x 0.25 mm²</p>	50m	097100 C-M08F04-04X025PV50,0-ES-097100
	10m	084703 C-M08F04-04X025PV10,0-ES-084703
<p>M8 4 pin PUR</p> <p>Connecting cable with female plug, flying lead, 4 x 0.34 mm²</p>	5m	116049 C-M08F04-04X034PU05,0-ES-116049
	10m	116050 C-M08F04-04X034PU10,0-ES-116050
	20m	116051 C-M08F04-04X034PU20,0-ES-116051
	50m	120241 C-M08F04-04X034PU50,0-ES-120241

For detailed information, enter the order number for the product in the search box at www.euchner.com.

Connecting cables with plug connector

For LED indicator of read heads CEM

For the connection of:

CEM-LH10-...

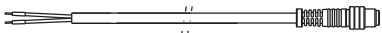

Version	Order no./item	
<div style="display: flex; align-items: center;"> <div style="margin-right: 10px;"> <p>M8</p> <p>4 pin</p> <p>PVC</p> </div> <div style="text-align: center;"> <p>Connecting cable with male plug, flying lead, 4 x 0.25 mm²</p>  </div> </div>	2m	<p>088841 C-M08M04-04X025PV02,0-ES-088841</p>
	5m	<p>088842 C-M08M04-04X025PV05,0-ES-088842</p>
	10m	<p>088843 C-M08M04-04X025PV10,0-ES-088843</p>
	15m	<p>088844 C-M08M04-04X025PV15,0-ES-088844</p>

For detailed information, enter the order number for the product in the search box at www.euchner.com.

M12 5 pin PVC PUR

Connecting cables with plug connector

For the connection of:

CES-FD-AP...



Version	Order no./item	
Connecting cable with female plug, flying lead, 5 x 0.34 mm², screened 	5m	100183 C-M12F05-05X034PV05,0-MA-100183
	10m	100184 C-M12F05-05X034PV10,0-MA-100184
	20m	100185 C-M12F05-05X034PV20,0-MA-100185
	50m	156064 C-M12F05-05X034PV50,0-MA-156064
Extension, plug connectors at both ends for connection to decentralized peripheral equipment 	5m	100180 C-M12F05-05X034PV05,0-M12M05-100180
	10m	100181 C-M12F05-05X034PV10,0-M12M05-100181
	20m	100182 C-M12F05-05X034PV20,0-M12M05-100182
Connecting cable with female plug, flying lead, 5 x 0.34 mm², screened 	5m	113620 C-M12F05-05X034PU05,0-MA-113620
	10m	113640 C-M12F05-05X034PU10,0-MA-113640
	20m	113682 C-M12F05-05X034PU20,0-MA-113682
	30m	122784 C-M12F05-05X034PU30,0-MA-113682
Extension, plug connectors at both ends for connection to decentralized peripheral equipment 	5m	119932 C-M12F05-05X034PU05,0-M12M05-119932
	10m	119947 C-M12F05-05X034PU10,0-M12M05-119947
	20m	119971 C-M12F05-05X034PU20,0-M12M05-119971

For detailed information, enter the order number for the product in the search box at www.euchner.com.

Connecting cables with plug connector

For the connection of:

CET-AX-...-SA
CET-AX-...-SE
CET-AX-...-SF

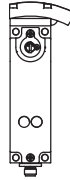

Version		Order no./item	
<p>M12 8 pin PVC</p> <p>Connecting cable with female plug, flying lead, 7 x 0.25 mm², screened ¹⁾</p>	10m	099633 C-M12F08-07X025PV10,0-MA-099633	<p>For detailed information, enter the order number for the product in the search box at www.euchner.com.</p>
	20m	099634 C-M12F08-07X025PV20,0-MA-099634	
	25m	103115 C-M12F08-07X025PV25,0-MA-103115	
<p>Connecting cable with female plug, flying lead, 7 x 0.25 mm², screened ¹⁾</p>	10m	100456 C-M12F08-07X025PV10,0-MA-100456	
	20m	105071 C-M12F08-07X025PV20,0-MA-105071	
<p>M12 8 pin PUR</p> <p>Connecting cable with female plug, flying lead, 7 x 0.25 mm², screened ¹⁾</p>	10m	102218 C-M12F08-07X025PU10,0-MA-102218	
	25m	103782 C-M12F08-07X025PU25,0-MA-103782	

1) Two wires in the cable are screened



Cables with coupling socket/female plug

Cables for extending the read head connecting cable

For the connection of:

CES-AL...



CEM-AL...



Version		Order no./item	
 + PE 	Extension, female plug BS4C1851 at one end, flying lead, 2 x 0.25 mm², screened 	1,5m 103667 C-M18F04-02X025PV01,5-ES-103667	For detailed information, enter the order number for the product in the search box at www.euchner.com .
	Extension, plug connectors at both ends, coupling socket KD4C1851/ cable socket M8 (3-pin), 2 x 0.25 mm², screened 	15m 103647 C-M08F03-02X025PV15,0-M18M04-103647	
		18m 128046 C-M08F03-02X025PV18,0-M18M04-128046	

Coupling socket/female plug

Plug connector for extending the read head connecting cable

For the connection of:

CES-AL...



CEM-AL...



Version	Comment	Order no.	
 + PE	Coupling socket 	077434 KD4C1851	For detailed information, enter the order number for the product in the search box at www.euchner.com .
Female plug 	Female plug for coupling socket KD4C1851	077435 BS4C1851	



Inrush current limiting module PM-SCL

Limits the switch-on current on CES evaluation units and in this way protects the switching contacts

For the connection of:

CES-AZ...



Version	Order no.	
Inrush current limiting module PM-SCL  For CES evaluation units	096945 PM-SCL-096945	For detailed information, enter the order number for the product in the search box at www.euchner.com .

Dimension drawing and connection options

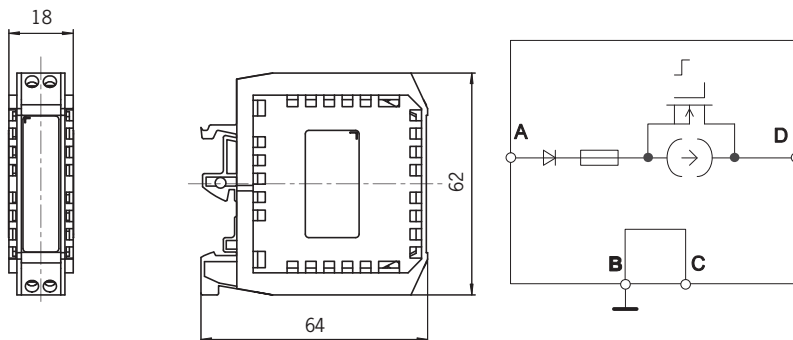

Bolts



Bolts for read heads CES

Notice: On these bolts, the actuators are integrated into the bolt tongue and are included.

For mounting:

CES-ALNA...



Designation	Detent mechanism/ door gap	Material	Version	Order no.	
	Bolt CES-A-A Closed position: ball detent mechanism Open position: none/ door gap: 15 mm	Steel	For doors hinged on the right or left	076487 BOLT CES-AA	For detailed information, enter the order number for the product in the search box at www.euchner.com .
	Bolt CES-A-A/F Closed position: ball detent mechanism Open position: detent knob/ door gap: 15 mm	Steel	For doors hinged on the right or left, with lever for escape release from the danger area	086173 BOLT CES-A-A/F	

Bolts for read heads CEM

Notice: The actuators are **not** included with these bolts.

For mounting:

CEM-ALE05...



Designation	Detent mechanism/ door gap	Material	Version	Order no.	
	None/ door gap: 15 mm	Steel	For doors hinged on the right	097955 BOLT CEM-A	For detailed information, enter the order number for the product in the search box at www.euchner.com .
			For doors hinged on the left	097957 BOLT CEM-C	

Bolts for read head CET

Notice: Actuators are **not** included with these bolts.
Cover (protection against tampering) for CET actuators included.

For mounting:

CET.-AX-...

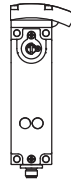



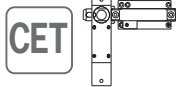







Designation	Detent mechanism/ door gap	Material	Version	Order no.	
Bolt CET-A-C	None/ door gap: 15 mm	Steel	For doors hinged on the right or left	104309 BOLT CET-A-C	For detailed information, enter the order number for the product in the search box at www.euchner.com .
Bolt CET-A-C/F	Closed position: none Open position: detent knob/ door gap: 15 mm	Steel	For doors hinged on the right or left, for CET with escape release	106172 BOLT CET-A-C/F	
Bolt CET-A-C/F-C2282	Closed position: none Open position: detent knob/ door gap: 15 mm	Steel, guide strip made of stainless steel	For doors hinged on the right or left, for CET with escape release	106350 BOLT CET-A-C/F-C2282	
Bolt CET-A-C-C2308	None/ door gap: 15 mm	Steel	For doors hinged on the right or left. Bolt can be opened outward and inward (no end stop).	109672 BOLT CET-A-C-C2308	

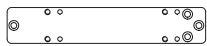

Fixing material

Mounting sets/mounting plates

Series	Use	Order no./item		
 <p>Mounting plate EMP-L-CEM05</p> 	For read head CEM-A-LE05...	099425 EMP-L-CEM05	<p>For detailed information, enter the order number for the product in the search box at www.euchner.com.</p>	
	<p>Mounting plate EMP-B-CEM05</p> 	For actuator CEM-A-BE05...		100110 EMP-B-CEM05
<p>Mounting plate EMP-L-CET</p> 	For read head CET-AX	106695 EMP-L-CET		
<p>Mounting plate EMP-B-CET</p> 	For actuator CET	106694 EMP-B-CET		
 <p>Mounting plate EMP-B1</p> 	For actuator CET	093457 EMP-B1		
	<p>Mounting plate AM-P</p> 	For read head CET-AX		126399 AM-P-126399
	<p>Mounting plate AM-P</p> 	For actuator CET		126400 AM-P-126400
<p>Mounting plate with handle</p> 	Can be combined with mounting plates AM-P-126399 and AM-P-126400	126398 AM-P-126398		

Clamping pieces for aluminum profiles











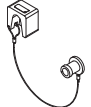

Fixing material	Version/usage	Packaging unit [qty.]	Order no.
Installation material for Bosch profiles with 8-mm slot	Read heads CES-A-LSP and actuators CES-A-BSP	Two screws + Two clamping pieces	106633
Installation material for Bosch profiles with 10-mm slot			106634
Installation material for ITEM profiles with 8-mm slot			106635

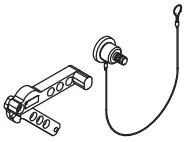
Miscellaneous accessories

Safety screws

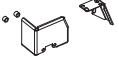
Fixing material/screw size	Version/usage	Packaging unit [qty.]	Order no.
Safety screws, stainless steel M4 x 14 (small head)	Read heads CES-A-LN..., CES-A-LC..., CES-A-LQ... and actuators CES-A-BB..., CES-A-BCA, CES-A-BQ...	20	071863
Safety screws, stainless steel M4 x 14 (large head)	Field evaluation unit CES-FD-AP...	100	086232
Safety screws M5 x 16	Read heads CEM-A-LE... and actuators CETA-BWK, CEM-A-B...	100	073456

Miscellaneous accessories

Designation	Use	Version	Order no.
 Lockout bar 	For actuator CEM-A-BE05	Suitable for 3x shackle diameter 4 ... 9 mm	122404 AE-L-BE05-R-122404
Lockout bar 	For actuator CET	Suitable for shackle diameter 5 ... 6 mm	122609 AE-L-CET-122609
Lockout bar 	For actuator CET	Suitable for shackle diameter 5 mm - 9 mm	156429 AE-L-CET-156429
Holder for lockout bar 	For lockout bar AE-L-CET-156420	Including wire rope and ring to hang the wire rope onto the lockout bar	156338 AY-CHN-A1-156338
Lockout bar + holder set 	For actuator CET	Suitable for shackle diameter 5 mm - 9 mm. Holder including wire rope and ring to hang the wire rope onto the lockout bar.	155865 AE-SET-LCHN-A1-155865
 Mechanical key release 	For read head CET-AX	Identical locking, including two keys	098850
Replacement key	For mechanical key release, identical locking	Two keys, identical locking	099434
Emergency unlocking 	For read head CET-AX	Latching in both positions	103714
Lead seal kit	For emergency unlocking	–	087256
Cover 	For read head CET-AX and actuator CET	Door hinge right	098808
		Door hinge left	098807
Cover 	For actuator CET	For horizontal and vertical fastening on the actuator (suitable for fixing screws M5 x 16)	124979 AM-C-124979
Double ramp 	For read head CET-AX	–	114091 CET-DR
Extension for escape release 	For read head CET-AX with escape release	Extension by 30/50/80 mm, pushbutton Ø 40 mm	127377 AF-E-80-127377

Index by item designation

Item	Order no.	Page	Item	Order no.	Page
AE-L-BE05-R-122404	122404	77	C-M12F08-07X025PV10,0-MA-100456	100456	69
AE-L-CET-122609	122609	77	C-M12F08-07X025PV20,0-MA-099634	099634	69
AE-L-CET-156429	156429	77	C-M12F08-07X025PV20,0-MA-105071	105071	69
AE-SET-L-CHN-A1-155865	155865	77	C-M12F08-07X025PV25,0-MA-103115	103115	69
AF-E-80-127377	127377	77	C-M18F04-02X025PV01,5-ES-103667	103667	70
AM-C-124979	124979	77	CEM-A-BE05	094805	42
AMP-126398	126398	74	CEM-A-BE05	094805	46
AMP-126399	126399	74	CEM-A-BH10	095175	48
AMP-126400	126400	74	CEM-A-LE05H-S2	104606	46
AY-CHN-A1-156338	156338	77	CEM-A-LE05K-S2	094800	42
BS4C1851	077435	70	CEM-A-LE05R-S2	095792	42
C-M05F04-02X014PV05,0-ES-105555	105555	64	CEM-A-LH10K-S3	095170	48
C-M05F04-02X014PV10,0-ES-105556	105556	64	CEM-A-LH10R-S3	095793	48
C-M05F04-02X014PV20,0-ES-105559	105559	64	CEM-A-ME05K-S1-109755	109755	42
C-M08F03-02X025PU05,0-ES-084762	084762	65	CES-A-BBA	071840	34
C-M08F03-02X025PU10,0-ES-084763	084763	65	CES-A-BBN-106600	106600	30
C-M08F03-02X025PU10,0-ES-098590	098590	65	CES-A-BCA	088786	33
C-M08F03-02X025PU15,0-ES-084764	084764	65	CES-A-BDN-06-104730	104730	30
C-M08F03-02X025PU20,0-ES-084765	084765	65	CES-A-BMB	077791	38
C-M08F03-02X025PU25,0-ES-084766	084766	65	CES-A-BQA	098108	34
C-M08F03-02X025PU25,0-ES-120280	120280	65	CES-A-BSP-104970	104970	36
C-M08F03-02X025PV03,0-ES-077935	077935	65	CES-A-LCA-10V	088785	32
C-M08F03-02X025PV05,0-ES-077793	077793	65	CES-A-LMN-SC	077790	38
C-M08F03-02X025PV10,0-ES-077767	077767	65	CES-A-LNA-05P	077806	32
C-M08F03-02X025PV10,0-ES-084701	084701	65	CES-A-LNA-05V	071845	32
C-M08F03-02X025PV15,0-M18M04-103647	103647	70	CES-A-LNA-10P	077807	32
C-M08F03-02X025PV18,0-M18M04-128064	128064	70	CES-A-LNA-10V	071846	32
C-M08F03-02X025PV20,0-ES-077716	077716	65	CES-A-LNA-15P	084682	32
C-M08F03-02X025PV25,0-ES-077717	077717	65	CES-A-LNA-15V	071847	32
C-M08F03-02X025PV25,0-ES-099998	099998	65	CES-A-LNA-25V	071975	32
C-M08F04-04X025PV02,0-ES-088812	088812	66	CES-A-LNA-SC	077715	32
C-M08F04-04X025PV05,0-ES-088813	088813	66	CES-A-LNN-05V-106602	106602	30
C-M08F04-04X025PV10,0-ES-084703	084703	66	CES-A-LNN-10V-113294	113294	30
C-M08F04-04X025PV10,0-ES-088814	088814	66	CES-A-LNN-25V-115107	115107	30
C-M08F04-04X025PV15,0-ES-088815	088815	66	CES-A-LNN-SC-106601	106601	30
C-M08F04-04X025PV25,0-ES-095035	095035	66	CES-A-LQA-SC	095650	34
C-M08F04-04X025PV50,0-ES-097100	097100	66	CES-A-LSP-05V-104966	104966	36
C-M08F04-04X034PU05,0-ES-116049	116049	66	CES-A-LSP-10V-104967	104967	36
C-M08F04-04X034PU10,0-ES-116050	116050	66	CES-A-LSP-SB-104969	104969	36
C-M08F04-04X034PU20,0-ES-116051	116051	66	CES-AZ-AES-01B	104770	18
C-M08F04-04X034PU50,0-ES-120241	120241	66	CES-AZ-AES-02B	104775	20
C-M08M03-02X025PU0,4-M08F03-115464	115464	65	CES-AZ-UES-01B	105139	18
C-M08M04-04X025PV02,0-ES-088841	088841	67	CES-AZ-UES-02B	105140	20
C-M08M04-04X025PV05,0-ES-088842	088842	67	CES-EA-TC-AK04-104756	104756	18
C-M08M04-04X025PV10,0-ES-088843	088843	67	CES-EA-TC-AK06-104771	104771	20
C-M08M04-04X025PV15,0-ES-088844	088844	67	CES-EA-TC-KK04-112631	112631	18
C-M12F05-05X034PU05,0-M12M05-119932	119932	68	CES-EA-TC-KK06-112630	112630	20
C-M12F05-05X034PU05,0-MA-113620	113620	68	CES-FD-AP-M-01-USI-115534	115534	26
C-M12F05-05X034PU10,0-M12M05-119947	119947	68	CES-FD-AP-U-01-USI-119865	119865	26
C-M12F05-05X034PU10,0-MA-113640	113640	68	CET-A-BWK-50X	096327	54
C-M12F05-05X034PU20,0-M12M05-119971	119971	68	CET-DR	114091	77
C-M12F05-05X034PU20,0-MA-113682	113682	68	CET1-AX-LDA-00-50F-SA	103750	53
C-M12F05-05X034PU30,0-MA-113682	122784	68	CET1-AX-LDA-00-50X-SC	103444	53
C-M12F05-05X034PV05,0-M12M05-100180	100180	68	CET1-AX-LDA-00-50X-SE	100399	53
C-M12F05-05X034PV05,0-MA-100183	100183	68	CET1-AX-LRA-00-50F-SA	102161	53
C-M12F05-05X034PV10,0-M12M05-100181	100181	68	CET1-AX-LRA-00-50L-SA	104062	53
C-M12F05-05X034PV10,0-MA-100184	100184	68	CET1-AX-LRA-00-50X-SA	095735	53
C-M12F05-05X034PV20,0-M12M05-100182	100182	68	CET1-AX-LRA-00-50X-SC	102988	53
C-M12F05-05X034PV20,0-MA-100185	100185	68	CET1-AX-LRA-00-50X-SF	104051	53
C-M12F05-05X034PV50,0-MA-156064	156064	68	CET2-AX-LRA-00-50X-SA	106039	53
C-M12F08-07X025PU10,0-MA-102218	102218	69	CET2-AX-LRA-00-50X-SC	109932	53
C-M12F08-07X025PU25,0-MA-103782	103782	69	CKS-A-BK1-RD-113461	113461	60
C-M12F08-07X025PV10,0-MA-099633	099633	69	CKS-A-L1B-SC-113130	113130	60

Index by order number

Order no.	Item	Page
071840	CES-A-BBA	34
071845	CES-A-LNA-05V	32
071846	CES-A-LNA-10V	32
071847	CES-A-LNA-15V	32
071863		76
071975	CES-A-LNA-25V	32
073456		76
076487	RIEGEL CES-A-A	72
077434	KD4C1851	70
077435	BS4C1851	70
077715	CES-A-LNA-SC	32
077716	C-M08F03-02X025PV20,0-ES-077716	65
077717	C-M08F03-02X025PV25,0-ES-077717	65
077767	C-M08F03-02X025PV10,0-ES-077767	65
077790	CES-A-LMN-SC	38
077791	CES-A-BMB	38
077793	C-M08F03-02X025PV05,0-ES-077793	65
077806	CES-A-LNA-05P	32
077807	CES-A-LNA-10P	32
077935	C-M08F03-02X025PV03,0-ES-077935	65
084682	CES-A-LNA-15P	32
084701	C-M08F03-02X025PV10,0-ES-084701	65
084703	C-M08F04-04X025PV10,0-ES-084703	66
084762	C-M08F03-02X025PU05,0-ES-084762	65
084763	C-M08F03-02X025PU10,0-ES-084763	65
084764	C-M08F03-02X025PU15,0-ES-084764	65
084765	C-M08F03-02X025PU20,0-ES-084765	65
084766	C-M08F03-02X025PU25,0-ES-084766	65
086173	RIEGEL CES-A-A/F	72
086232		76
087256		77
088785	CES-A-LCA-10V	32
088786	CES-A-BCA	33
088812	C-M08F04-04X025PV02,0-ES-088812	66
088813	C-M08F04-04X025PV05,0-ES-088813	66
088814	C-M08F04-04X025PV10,0-ES-088814	66
088815	C-M08F04-04X025PV15,0-ES-088815	66
088841	C-M08M04-04X025PV02,0-ES-088841	67
088842	C-M08M04-04X025PV05,0-ES-088842	67
088843	C-M08M04-04X025PV10,0-ES-088843	67
088844	C-M08M04-04X025PV15,0-ES-088844	67
093457	EMP-B1	74
094800	CEM-A-LE05K-S2	42
094805	CEM-A-BE05	42
094805	CEM-A-BE05	46
095035	C-M08F04-04X025PV25,0-ES-095035	66
095170	CEM-A-LH10K-S3	48
095175	CEM-A-BH10	48
095650	CES-A-LQA-SC	34
095735	CET1-AX-LRA-00-50X-SA	53
095792	CEM-A-LE05R-S2	42
095793	CEM-A-LH10R-S3	48
096327	CET-A-BWK-50X	54
096945	PM-SCL-096945	71
097100	C-M08F04-04X025PV50,0-ES-097100	66
097955	RIEGEL CEM-A	72
097957	RIEGEL CEM-C	72
098108	CES-A-BQA	34
098590	C-M08F03-02X025PU10,0-ES-098590	65
098807		77
098808		77
098850		77
099425	EMP L CEM05	74

Order no.	Item	Page
099434		77
099633	C-M12F08-07X025PV10,0-MA-099633	69
099634	C-M12F08-07X025PV20,0-MA-099634	69
099998	C-M08F03-02X025PV25,0-ES-099998	65
100110	EMP B CEM05	74
100180	C-M12F05-05X034PV05,0-M12M05-100180	68
100181	C-M12F05-05X034PV10,0-M12M05-100181	68
100182	C-M12F05-05X034PV20,0-M12M05-100182	68
100183	C-M12F05-05X034PV05,0-MA-100183	68
100184	C-M12F05-05X034PV10,0-MA-100184	68
100185	C-M12F05-05X034PV20,0-MA-100185	68
100399	CET1-AX-LDA-00-50X-SE	53
100456	C-M12F08-07X025PV10,0-MA-100456	69
102161	CET1-AX-LRA-00-50F-SA	53
102218	C-M12F08-07X025PU10,0-MA-102218	69
102988	CET1-AX-LRA-00-50X-SC	53
103115	C-M12F08-07X025PV25,0-MA-103115	69
103444	CET1-AX-LDA-00-50X-SC	53
103647	C-M08F03-02X025PV15,0-M18M04-103647	70
103667	C-M18F04-02X025PV01,5-ES-103667	70
103714		77
103750	CET1-AX-LDA-00-50F-SA	53
103782	C-M12F08-07X025PU25,0-MA-103782	69
104051	CET1-AX-LRA-00-50X-SF	53
104062	CET1-AX-LRA-00-50L-SA	53
104309	RIEGEL CET-A-C	73
104606	CEM-A-LE05H-S2	46
104730	CES-A-BDN-06-104730	30
104756	CES-EA-TC-AK04-104756	18
104770	CES-AZ-AES-01B	18
104771	CES-EA-TC-AK06-104771	20
104775	CES-AZ-AES-02B	20
104966	CES-A-LSP-05V-104966	36
104967	CES-A-LSP-10V-104967	36
104969	CES-A-LSP-SB-104969	36
104970	CES-A-BSP-104970	36
105071	C-M12F08-07X025PV20,0-MA-105071	69
105139	CES-AZ-UES-01B	18
105140	CES-AZ-UES-02B	20
105555	C-M05F04-02X014PV05,0-ES-105555	64
105556	C-M05F04-02X014PV10,0-ES-105556	64
105559	C-M05F04-02X014PV20,0-ES-105559	64
106039	CET2-AX-LRA-00-50X-SA	53
106172	RIEGEL CET-A-C/F	73
106350	RIEGEL CET-A-C/F-C2282	73
106600	CES-A-BBN-106600	30
106601	CES-A-LNN-SC-106601	30
106602	CES-A-LNN-05V-106602	30
106633		75
106634		75
106635		75
106694	EMP-B-CET	74
106695	EMP-L-CET	74
109672	RIEGEL CET-A-C-C2308	73
109755	CEM-A-ME05K-S1-109755	42
109932	CET2-AX-LRA-00-50X-SC	53
112630	CES-EA-TC-KK06-112630	20
112631	CES-EA-TC-KK04-112631	18
113130	CKS-A-LB-SC-113130	60
113294	CES-A-LNN-10V-113294	30
113461	CKS-A-BK1-RD-113461	60
113620	C-M12F05-05X034PU05,0-MA-113620	68
113640	C-M12F05-05X034PU10,0-MA-113640	68

Representatives

International

Austria

EUCHNER GmbH
Aumühlweg 17-19/Halle 1C
2544 Leobersdorf
Tel. +43 720 010 200
Fax +43 720 010 200-20
info@euchner.at

Benelux

EUCHNER (BENELUX) BV
Visschersbuurt 23
3356 AE Papendrecht
Tel. +31 78 615-4766
Fax +31 78 615-4311
info@euchner.nl

Brazil

EUCHNER Com.Comp.
Eletronicos Ltda.
Av. Prof. Luiz Ignácio Anhaia Mello,
no. 4387
Vila Graciosa
São Paulo - SP - Brasil
CEP 03295-000
Tel. +55 11 29182200
Fax +55 11 23010613
euchner@euchner.com.br

Canada

EUCHNER Canada Inc.
2105 Fasan Drive
Oldcastle, ON NOR 1L0
Tel. +1 519 800-8397
Fax +1 519 737-0314
sales@euchner.ca

China

EUCHNER (Shanghai)
Trading Co., Ltd.
No. 15 building,
No. 68 Zhongchuang Road,
Songjiang
Shanghai, 201613, P.R.C
Tel. +86 21 5774-7090
Fax +86 21 5774-7599
info@euchner.com.cn

Czech Republic

EUCHNER electric s.r.o.
Trnkova 3069/117h
628 00 Brno
Tel. +420 533 443-150
Fax +420 533 443-153
info@euchner.cz

Denmark

Duelco A/S
Systemvej 8 - 10
9200 Aalborg SV
Tel. +45 7010 1007
Fax +45 7010 1008
info@duelco.dk

Finland

Sähkölehto Oy
Holkkitie 14
00880 Helsinki
Tel. +358 9 7746420
office@sahkolehto.fi

France

EUCHNER France S.A.R.L.
Parc d'Affaires des Bellevues
Allée Rosa Luxembourg
Bâtiment le Colorado
95610 ERAGNY sur OISE
Tel. +33 1 3909-9090
Fax +33 1 3909-9099
info@euchner.fr

Hungary

EUCHNER Magyarország Kft.
FSD Park 2.
2045 Törökbálint
Tel. +36 1 919 0855
Fax +36 1 919 0857
info@euchner.hu

India

EUCHNER (India) Pvt. Ltd.
401, Bremen Business Center,
City Survey No. 2562,
University Road
Aundh, Pune - 411007
Tel. +91 20 64016384
Fax +91 20 25885148
info@euchner.in

Israel

Ilan & Gavish Automation Service Ltd.
26 Shenkar St. Qiryat Arie 49513
P.O. Box 10118
Petach Tikva 49001
Tel. +972 3 9221824
Fax +972 3 9240761
mail@ilan-gavish.com

Italy

TRITECNICA SpA
Viale Lazio 26
20135 Milano
Tel. +39 02 541941
Fax +39 02 55010474
info@tritecnica.it

Japan

EUCHNER Co., Ltd.
1662-3 Komakiharashinden
Komakishi, Aichi-ken
485-0012, Japan
Tel. +81 568 42 0157
Fax +81 568 42 0159
info@euchner.jp

Korea

EUCHNER Korea Co., Ltd.
115 Gasan Digital 2 - Ro
(Gasan-dong, Daeryung
Technotown 3rd Rm 810)
153 - 803 Kumchon-Gu, Seoul
Tel. +82 2 2107-3500
Fax +82 2 2107-3999
info@euchner.co.kr

Mexico

EUCHNER México S de RL de CV
Conjunto Industrial PK Co.
Carretera Estatal 431 km. 1+300
Ejido El Colorado, El Marqués
76246 Querétaro, México
Tel. +52 442 402 1485
Fax +52 442 402 1486
info@euchner.mx

Poland

ELTRON
Pl. Wolności 7B
50-071 Wrocław
Tel. +48 71 3439755
Fax +48 71 3441141
eltron@eltron.pl

Portugal

PAM Servicos Tecnicos Industriais Lda.
Rua de Timor - Pavilhao 2A
Zona Industrial da Abelheira
4785-123 Trofa
Tel. +351 252 418431
Fax +351 252 494739
pam@mail.telepac.pt

Republic of South Africa

RUBICON
ELECTRICAL DISTRIBUTORS
4 Reith Street, Sidwell
6061 Port Elizabeth
Tel. +27 41 451-4359
Fax +27 41 451-1296
sales@rubiconelectrical.com

Romania

First Electric SRL
Str. Ritmului Nr. 1 Bis
Ap. 2, Sector 2
021675 Bucuresti
Tel. +40 21 2526218
Fax +40 21 3113193
office@firstelectric.ro

Singapore

BM Safety Singapore Pte Ltd.
Blk 3, Ang Mo Kio Industrial Park 2A
#05-06
Singapore 568050
Tel. +65 6744 8018
Fax +65 6744 1929
sales@bmsafety.com.sg

Slovakia

EUCHNER electric s.r.o.
Trnkova 3069/117h
628 00 Brno
Tel. +420 533 443-150
Fax +420 533 443-153
info@euchner.cz

Slovenia

SMM proizvodni sistemi d.o.o.
Jaskova 18
2000 Maribor
Tel. +386 2 4502326
Fax +386 2 4625160
franc.kit@smm.si

Spain

EUCHNER, S.L.
Gurutzezi 12 - Local 1
Poligono Belartza
20018 San Sebastian
Tel. +34 943 316-760
Fax +34 943 316-405
info@euchner.es

Sweden

Censit AB
Box 331
33123 Värnamo
Tel. +46 370 691010
Fax +46 370 18888
info@censit.se

Switzerland

EUCHNER AG
Falknisstrasse 9a
7320 Sargans
Tel. +41 81 720-4590
Fax +41 81 720-4599
info@euchner.ch

Taiwan

Daybreak Int'l (Taiwan) Corp.
3F, No. 124, Chung-Cheng Road
Shihlin 11145, Taipei
Tel. +886 2 8866-1234
Fax +886 2 8866-1239
day111@ms23.hinet.net

Turkey

EUCHNER Endüstriyel Emniyet
Teknolojileri Ltd. Şti.
Hattat Bahattin Sok.
Ceylan Apt. No. 13/A
Göztepe Mah.
34730 Kadıköy /Istanbul
Tel. +90 216 359-5656
Fax +90 216 359-5660
info@euchner.com.tr

United Kingdom

EUCHNER (UK) Ltd.
Unit 2 Petre Drive,
Sheffield
South Yorkshire
S4 7PZ
Tel. +44 114 2560123
Fax +44 114 2425333
sales@euchner.co.uk

USA

EUCHNER USA Inc.
6723 Lyons Street
East Syracuse, NY 13057
Tel. +1 315 701-0315
Fax +1 315 701-0319
info@euchner-usa.com

EUCHNER USA Inc.
Detroit Office
130 Hampton Circle
Rochester Hills, MI 48037
Tel. +1 248 537-1092
Fax +1 248 537-1095
info@euchner-usa.com

Germany

Augsburg

EUCHNER GmbH + Co. KG
Ingenieur- und Vertriebsbüro
Julius-Spokojny-Weg 8
86153 Augsburg
Tel. +49 821 56786540
Fax +49 821 56786541
peter.klopper@euchner.de

Berlin

EUCHNER GmbH + Co. KG
Ingenieur- und Vertriebsbüro
Ulmestraße 115a
12621 Berlin
Tel. +49 30 50508214
Fax +49 30 56582139
alexander.walz@euchner.de

Chemnitz

EUCHNER GmbH + Co. KG
Ingenieur- und Vertriebsbüro
Am Vogelherd 2
09627 Bobritzsch-Hilbersdorf
Tel. +49 37325 906000
Fax +49 37325 906004
jens.zehrtner@euchner.de

Düsseldorf

EUCHNER GmbH + Co. KG
Ingenieur- und Vertriebsbüro
Tippgarten 3
59427 Unna
Tel. +49 2308 9337284
Fax +49 2308 9337285
christian.schimke@euchner.de

Essen

Thomas Kreißl
fördern - steuern - regeln
Hackenbergweg 8a
45133 Essen
Tel. +49 201 84266-0
Fax +49 201 84266-66
info@kreissl-essen.de

Freiburg

EUCHNER GmbH + Co. KG
Ingenieur- und Vertriebsbüro
Steige 5
79206 Breisach
Tel. +49 7664 403833
Fax +49 7664 403834
peter.seifert@euchner.de

Lübeck

EUCHNER GmbH + Co. KG
Ingenieur- und Vertriebsbüro
Am Stadtrand 13
23556 Lübeck
Tel. +49 451 88048371
Fax +49 451 88184364
martin.pape@euchner.de

Nürnberg

EUCHNER GmbH + Co. KG
Ingenieur- und Vertriebsbüro
Steiner Straße 22a
90522 Oberasbach
Tel. +49 911 6693829
Fax +49 911 6696722
ralf.paulus@euchner.de

Stuttgart

EUCHNER GmbH + Co. KG
Ingenieur- und Vertriebsbüro
Kohlhammerstraße 16
70771 Leinfelden-Echterdingen
Tel. +49 711 7597-0
Fax +49 711 7597-303
oliver.laier@euchner.de
uwe.kupka@euchner.de

Wiesbaden

EUCHNER GmbH + Co. KG
Ingenieur- und Vertriebsbüro
Adolfsallee 3
65185 Wiesbaden
Tel. +49 611 98817644
Fax +49 611 98895071
giancarlo.pasquesi@euchner.de



EUCHNER

More than safety.



Support hotline

You have technical questions about our products or how they can be used?
For further questions please contact your local sales representative.



Comprehensive download area

You are looking for more information about our products?
You can simply and quickly download operating instructions, CAD or ePLAN data and accompanying software for our products at www.euchner.com.



Customer-specific solutions

You need a specific solution or have a special requirement?
Please contact us. We can manufacture your custom product even in small quantities.



EUCHNER near you

You are looking for a contact at your location? Along with the headquarters in Leinfelden-Echterdingen, the worldwide sales network includes 17 subsidiaries and numerous representatives in Germany and abroad – you will definitely also find us near you.

www.euchner.com

EUCHNER GmbH + Co. KG

Kohlhammerstraße 16
70771 Leinfelden-Echterdingen
Germany
Tel. +49 711 7597-0
Fax +49 711 753316
info@euchner.de
www.euchner.com

EUCHNER

More than safety.