

OLED-DISPLAYS

INKL. KONTROLLER FÜR 4-/8-BIT UND SPI

neu: SPI



OLED										
Part-Number	Row x Column	Char height	Module size			Viewing Area		Accessories (Frames)	Hints	Drawing page
			W	H	D	W	H			
EA W082-XLG	2x8	5.5	58.0	32.0	10.0	38.0	16.0	---	yellow/green	8
EA W162-X3LW	2x16	5.5	80.0	36.0	10.0	66.0	16.0	EA 017-2U	icewhite	9
EA W162-X3LG	2x16	5.5						EA 017-2U	yellow/green	9
EA W162-XLG	2x16	5.5	84.0	44.0	10.0	66.0	16.0	EA 017-2U	yellow/green	10
EA W162-X9LG	2x16	5.5	85.0	36.0	10.0	66.0	16.0	EA 017-2U	yellow/green	11
EA W162-XBLW	2x16	8.9	122.0	44.0	10.0	99.0	24.0	EA 017-12U	icewhite	12
EA W162-XBLG	2x16	8.9						EA 017-12U	yellow/green	12
EA W202-XLG	2x20	5.5	116.0	37.0	9.8	85.0	18.6	EA 017-7U	yellow/green	13
EA W202-XDLG	2x20	9.66	180.0	40.0	9.3	149.0	23.0	---	yellow/green	14
EA W204-XLG	4x20	5.5	98.0	60.0	10.0	70.0	25.2	EA 017-9U	yellow/green	15

TECHNISCHE DATEN

- * INTEGRIERTER KONTROLLER (HD44780-ÄHNLICH)
- * EINGANG 4- ODER 8-BIT DATENBUS, 3 STEUERLEITUNGEN (R/W, E, RS)
- * SPI INTERFACE: MOSI, MISO, CLK, CS
- * ASCII-ZEICHENSATZ UND SONDERZEICHEN IM CHARACTER-ROM
- * BIS ZU 8 ZEICHEN (ASCII-CODE 0..7) KÖNNEN FREI DEFINIERT WERDEN
- * VERSCHIEDENE FUNKTIONEN MIT EINEM BEFEHL PROGRAMMIERBAR:
 - CLEAR DISPLAY, CURSOR HOME, CURSOR ON/OFF, BLINKING CURSOR
 - SHIFT DISPLAY, SHIFT CURSOR, READ/WRITE DISPLAY DATA, ETC.
- * EINFACHE SPANNUNGSVERSORGUNG (3.3..5V).
- * GERINGER STROMVERBRAUCH (15..50 mA)
- * BETRIEBSTEMPERATUR -40..+80°C
- * 4 INTEGRIERTE FONTS

ZUBEHÖR

- * ABDECKRAHMEN (SIEHE TABELLE)

**ELECTRONIC
ASSEMBLY**

making things easy

ZEICHENSÄTZE

ENGLISH_JAPANESE CHARACTER FONT TABLE(default FT[1:0]= 00)

Upper 4bit Lower 4bit	LLLL	LLLN	LLNL	LLNH	LNLL	LNLN	LNHL	LNHH	NLLL	NLLN	NLHL	NLHN	NNLL	NNLN	NNHL	NNHN
LLLL	CG RAM (1)															
LLLN	CG RAM (2)															
LLNL	CG RAM (3)															
LLNH	CG RAM (4)															
LNLL	CG RAM (5)															
LNLN	CG RAM (6)															
LNHL	CG RAM (7)															
LNHN	CG RAM (8)															
NLLL	CG RAM (9)															
NLLN	CG RAM (10)															
NLHL	CG RAM (11)															
NLHN	CG RAM (12)															
NNLL	CG RAM (13)															
NNLN	CG RAM (14)															
NNHL	CG RAM (15)															
NNHN	CG RAM (16)															

WESTERN EUROPEAN CHARACTER FONT TABLE I (FT[1:0]=01)

Upper 4bit Lower 4bit	LLLL	LLLN	LLNL	LLNH	LNLL	LNLN	LNHL	LNHH	NLLL	NLLN	NLHL	NLHN	NNLL	NNLN	NNHL	NNHN
LLLL	CG RAM (1)															
LLLN	CG RAM (2)															
LLNL	CG RAM (3)															
LLNH	CG RAM (4)															
LNLL	CG RAM (5)															
LNLN	CG RAM (6)															
LNHL	CG RAM (7)															
LNHN	CG RAM (8)															
NLLL	CG RAM (9)															
NLLN	CG RAM (10)															
NLHL	CG RAM (11)															
NLHN	CG RAM (12)															
NNLL	CG RAM (13)															
NNLN	CG RAM (14)															
NNHL	CG RAM (15)															
NNHN	CG RAM (16)															

ENGLISH RUSSIAN CHARACTER FONT TABLE(FT[1:0]=10)

Upper 4bit Lower 4bit	LLLL	LLLN	LLNL	LLNH	LNLL	LNLN	LNHL	LNHH	NLLL	NLLN	NLHL	NLHN	NNLL	NNLN	NNHL	NNHN
LLLL	CG RAM (1)															
LLLN	CG RAM (2)															
LLNL	CG RAM (3)															
LLNH	CG RAM (4)															
LNLL	CG RAM (5)															
LNLN	CG RAM (6)															
LNHL	CG RAM (7)															
LNHN	CG RAM (8)															
NLLL	CG RAM (9)															
NLLN	CG RAM (10)															
NLHL	CG RAM (11)															
NLHN	CG RAM (12)															
NNLL	CG RAM (13)															
NNLN	CG RAM (14)															
NNHL	CG RAM (15)															
NNHN	CG RAM (16)															

WESTERN EUROPEAN CHARACTER FONT TABLE II (FT[1:0]=11)

Upper 4bit Lower 4bit	LLLL	LLLN	LLNL	LLNH	LNLL	LNLN	LNHL	LNHH	NLLL	NLLN	NLHL	NLHN	NNLL	NNLN	NNHL	NNHN
LLLL	CG RAM (1)															
LLLN	CG RAM (2)															
LLNL	CG RAM (3)															
LLNH	CG RAM (4)															
LNLL	CG RAM (5)															
LNLN	CG RAM (6)															
LNHL	CG RAM (7)															
LNHN	CG RAM (8)															
NLLL	CG RAM (9)															
NLLN	CG RAM (10)															
NLHL	CG RAM (11)															
NLHN	CG RAM (12)															
NNLL	CG RAM (13)															
NNLN	CG RAM (14)															
NNHL	CG RAM (15)															
NNHN	CG RAM (16)															

Es ist möglich aus einem der hier abgebildeten Zeichensätze frei zu wählen. Standardmäßig wird der Englisch/Japanische Zeichensatz aktiviert. Hierfür müssen die Bits FT1/FT0 aus dem FunctionSet-Register entsprechend gesetzt werden:

FT 1	FT 0	Description
0	0	Englisch Japanese character font table
0	1	Western European character font table 1
1	0	English Russian character font table
1	1	Western European character font table 2

Anmerkung: Der Zeichensatz muss vor allen anderen Befehlen und Einstellungen ausgewählt werden (ausgenommen Busy-Flag-Abfrage und Adressoperationen).

PROGRAMMIERUNG VON SELBSTDEFINIERTEN ZEICHEN

Bei allen hier angebotenen OLED-Displays können zusätzlich zu den im ROM fest einprogrammierten Zeichen bis zu 8 weitere frei definiert werden (ASCII Codes 0..7).

- 1.) Mit dem Kommando "CG RAM Address Set" wird der ASCII Code (Bit 3,4,5) und die entsprechende Pixelzeile (Bit 0,1,2) des Zeichens angewählt. Im Beispiel wird ein Zeichen mit dem Code \$00 definiert.
- 2.) Mit dem Befehl "Data Write" wird nun Pixelzeile für Pixelzeile das Zeichen in das CG RAM geschrieben. Ein Zeichen benötigt 8 Schreiboperationen, wobei die 8. Zeile der Cursorzeile entspricht.
- 3.) Das neu definierte Zeichen wird genauso behandelt wie ein "normales" ASCII Zeichen (Verwendung: "DD RAM Address Set", "Data Write").

Adresse im CG RAM setzen		Zeichen	Daten des Zeichens								
Adresse	Hex		Bit								
			7	6	5	4	3	2	1	0	Hex
0 1 0 0 0	0 0 0	\$40									\$04
	0 0 1	\$41									\$04
	0 1 0	\$42									\$04
	0 1 1	\$43									\$04
	1 0 0	\$44									\$15
	1 0 1	\$45									\$0E
	1 1 0	\$46									\$04
	1 1 1	\$47									\$00

BEFEHLSSATZ

Instruction	Code										Description	Maximum execution time	
	RS	RW	DB7	DB6	DB5	DB4	DB3	DB2	DB1	DB0			
Clear Display	0	0	0	0	0	0	0	0	0	1	Clears entire Display, Sets DDRAM-address 0 into addresscounter	2 ms	
Return Home	0	0	0	0	0	0	0	0	0	1	0	Sets DDRAM-address 0 into addresscounter. Returns shifted display to original position. DDRAM contents remain unchanged.	0 ms
Entry Mode Set	0	0	0	0	0	0	0	1	I/D	S	Sets cursor move direction and specifies display shift.(These operations are performed during data write and read.)	0 ms	
Display On/Off Control	0	0	0	0	0	0	1	D	C	B	Sets entire Display (D) ON/OFF. Sets Cursor (C) ON/OFF. Sets Blinking (B) of Cursor Position Character.	0 ms	
Cursor/Display Shift/Mode/Pwr	0	0	0	0	1	S/C	R/L	0	0	Moves cursor and shifts display without changing DDRAMcontents.	0 ms		
						G/C (0)	PWR	1	1	Sets Graphic/Character Mode Sets internal power on/off	0 ms		
Function Set	0	0	0	0	1	DL	N	F	FT1	FT0	Sets interface data length (DL). Sets number of display lines (N). Sets Character Font (F). Sets Font Table (FT).	0 ms	
Set CGRAM Address	0	0	0	1	ACG	ACG	ACG	ACG	ACG	ACG	Sets CGRAM Address. CGRAM data is sent and received after this setting.	0 ms	
Set DDRAM Address	0	0	1	ADD	ADD	ADD	ADD	ADD	ADD	ADD	Sets DDRAM Address. The DDRAM data is sent and received after this setting.	0 ms	
Read Busy Flag and Address	0	1	BF	AC	AC	AC	AC	AC	AC	AC	Reads Busy Flag (BF) indicating that internal operation is being performed. Reads Address Counter contents.	0 ms	
Write data into the CGRAM or DDRAM	1	0	Write Data								Writes data into the CGRAM or DDRAM	0 ms	
Read data from the CGRAM or DDRAM	1	1	Read Data								Reads data from the CGRAM or DDRAM	0 ms	

Anmerkungen zum Befehlssatz:

- Nach Ausführen von CGRAM/DDRAM Read or Write Instruction, wird der RAM Address Counter incrementiert oder decrementiert. Nachdem das Busy Flag nicht mehr gesetzt ist, wird die RAM Adresse übernommen.
- I/D**=Increment/Decrement Bit
I/D="1": Incrementieren
I/D="0": Decrementieren
- S**=Shift Entire Display Control Bit.
S="0", shift function deaktiviert.
S="1", shift function aktiviert
- BF**=Busy Flag
BF="1": Interne Operationen werden durchgeführt
BF="0": Keine internen Operationen, der nächste Befehl kann entgegen genommen werden.
- R/L**=Shift Right/Left
R/L="1": Shift nach Rechts
R/L="0": Shift nach Links
- S/C**=Display Shift/Cursor Move
S/C="1": Display Shift
S/C="0": Cursor Move
- G/C**=Graphic/Character mode selection.
G/C="0", Character mode is selected.
G/C="1", Graphic mode is selected.
- PWR**=Internal DCDC on/of control.
PWR="1", DCDC an
PWR="0", DCDC aus
- DDRAM**=Display Data RAM
- CGRAM**=Character Generator RAM
- ACG**=CGRAM Address
- ADD**=Address Counter Address (corresponds to cursor address)
- AC**=Address Counter (used for DDRAM and CGRAM Addresses)
- F**=Character Pattern Mode
F="1": 5 x 10 dots
F="0": 5 x 8 dots
- N**=Number of Lines Displayed
N="1": 2- und 4-Line Display
N="0": 1-Line Display

INITIALISIERUNGSBEISPIELE

Initialisation example: 8-Bit / SPI											
RS	RW	DB7	DB6	DB5	DB4	DB3	DB2	DB1	DB0	HEX	Description
0	0	0	0	1	1	1	0	0	1	\$39	Function Set, western european character set, 8-Bit
0	0	0	0	0	0	1	0	0	0	\$08	Display off
0	0	0	0	0	0	0	1	1	0	\$06	Entry mode set, increment cursor by 1 not shifting display
0	0	0	0	0	1	0	1	1	1	\$17	Character mode and internal power on (have to on internal power to get the best brightness)
0	0	0	0	0	0	0	0	0	1	\$01	Clear display
0	0	0	0	0	0	0	0	1	0	\$02	Return home
0	0	0	0	0	0	1	1	0	0	\$0C	Display on

void `initDisplay(void)`

```
{ RS_DD=1; //RS Pin as output
RW_DD=1; //RW Pin as output
EN_DD=1; //EN Pin as output
WriteIns(0x39); //function set european character set
WriteIns(0x08); //display off
WriteIns(0x06); //entry mode set increment cursor by 1 not shifting display
WriteIns(0x17); //Character mode and internal power on
WriteIns(0x01); //clear display
WriteIns(0x02); //return home
WriteIns(0x0C); //display on
}
```

void `WriteIns(char instruction)`

```
{ CheckBusy();
DATA_PORT_DD=0xFF; //Dataport as Output
RS = 0;
RW = 0;
DATA_PORT = instruction; //set Data on Outputport
EN = 1; //set Enable to high
Wait(10); //wait 1us (stabilize Outputport)
EN = 0; //reset Enable to low
}
```

Initialisation example: 4-Bit											
RS	RW	DB7	DB6	DB5	DB4	DB3	DB2	DB1	DB0	HEX	Description
0	0	0	0	1	0	1	0	0	0	\$28	Function Set, English/Japanese char set, 4-Bit Note: Western European charset not available
0	0	0	0	0	0	1	0	0	0	\$08	Display off
0	0	0	0	0	0	0	1	1	0	\$06	Entry mode set, increment cursor by 1 not shifting display
0	0	0	0	0	1	0	1	1	1	\$17	Character mode and internal power on (have to on internal power to get the best brightness)
0	0	0	0	0	0	0	0	0	1	\$01	Clear display
0	0	0	0	0	0	0	0	1	0	\$02	Return home
0	0	0	0	0	0	1	1	0	0	\$0C	Display on

void `initDisplay(void)`

```
{ RS_DD=1; //RS-Pin as Output
EN_DD=1; //EN-Pin as Output
RW_DD=1; //RW-Pin as Output
RS = 0; //RS-Pin to low
RW = 0; //RW-Pin to low
EN = 0; //EN-Pin to low
send_nibble(0x03); //Be sure to
send_nibble(0x03); //be in
send_nibble(0x03); //8-Bit-Mode
send_nibble(0x02); //Switch to 4 Bit
Wait(50); //Wait 5us
WriteIns(0x28); //4-Bit-Mode
WriteIns(0x08); //display off
WriteIns(0x06); //entry mode set increment cursor by 1 not shifting display
WriteIns(0x17); //Character mode and internal power on
WriteIns(0x01); //clear display
WriteIns(0x02); //return home
WriteIns(0x0C); //display on
}
```

void `send_nibble(char data)`

```
{ DATA_PORT = data; //output data
EN=1;
Wait(10); //wait 1us (stabilize outupt)
EN=0;
Wait(10); //wait 1us (stabilize outupt)
}
```

void `WriteIns(char instruction)`

```
{ CheckBusy();
DATA_PORT_DD=0x0F; //Dataport as Output
RS = 0;
RW = 0;
send_nibble((instruction&0xF0)>>4); //Highbyte
send_nibble(instruction&0x0F); //Lowbyte
}
```

TIMING 4-/8-BIT INTERFACE

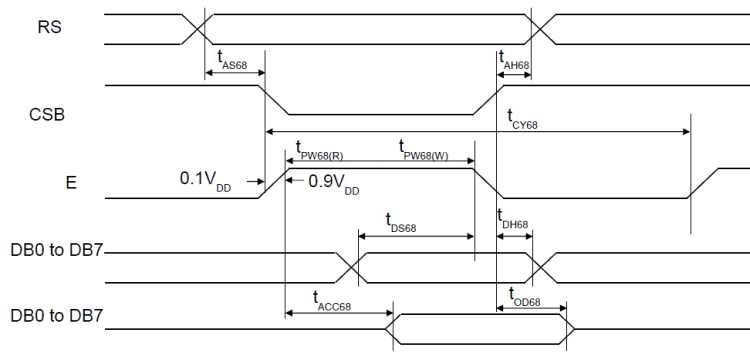

(VDD = 3.0 to 5.3V, Ta = 25°C)

Item	Signal	Symbol	Min.	Typ.	Max.	Unit	Remark
Address setup time	RS	t_{AS68}	20	-	-	ns	
Address hold time	RS	t_{AH68}	0	-	-	ns	
System cycle time		t_{CY68}	500	-	-	ns	
Pulse width (E)	E_RDB	$t_{PW68(W)}$	250	-	-	ns	
Pulse width (E)	E_RDB	$t_{PW68(R)}$	250	-	-	ns	
Data setup time	DB7	t_{DS68}	40	-	-	ns	
Data hold time	DB7	t_{DH68}	20	-	-	ns	
Read access time	to DB0	t_{Acc68}	-	-	180	ns	$C_L = 100pF$
Output disable time	DB0	t_{OD68}	10	-	-	ns	

ELECTRICAL CHARACTERISTICS

Item	Symbol	Test Condition	Standard Value			Unit
			min.	typ.	max	
Input "high" voltage	V _{IH}	-	0.9 VDD	-	VDD	V
Input "low" voltage	V _{IL}	-	GND	-	0.1 VDD	V
Output "high" voltage	V _{OH}	I _{OH} =-0.5mA	0.8 VDD	-	VDD	V
Output "low" voltage	V _{OL}	I _{OL} =0.5mA	GND	-	0.2 VDD	V
Power supply current	ICC	VDD=5V		15..50mA		A

VCC=5,0V, Ta=25°C

ABSOLUTE MAXIMUM RATINGS

Item	Symbol	Standard Value		Unit
		min.	max	
Power supply voltage for logic	VDD-GND	-0.3	5.3	V
Input Voltage	V _I	-0.3	VDD	V
Operating temperature	TOP	-40	80	°C
Storage Temperature	TST	-40	80	°C

Bei Versorgung mit 3,3V, ist die Helligkeit gegenüber 5V reduziert.

SPI INSTRUCTION DIAGRAM

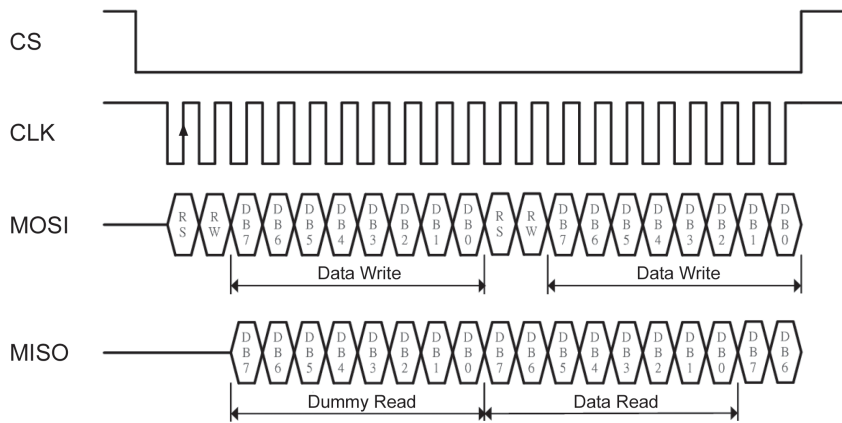

SPI DATA TRANSMISSION DIAGRAM

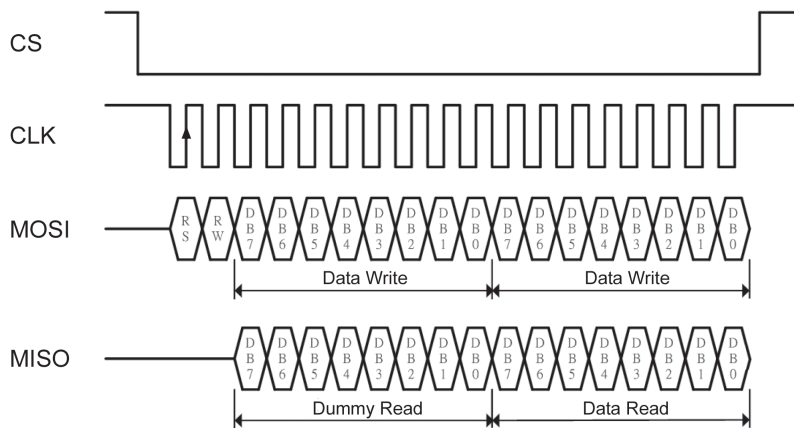

TIMING SPI INTERFACE

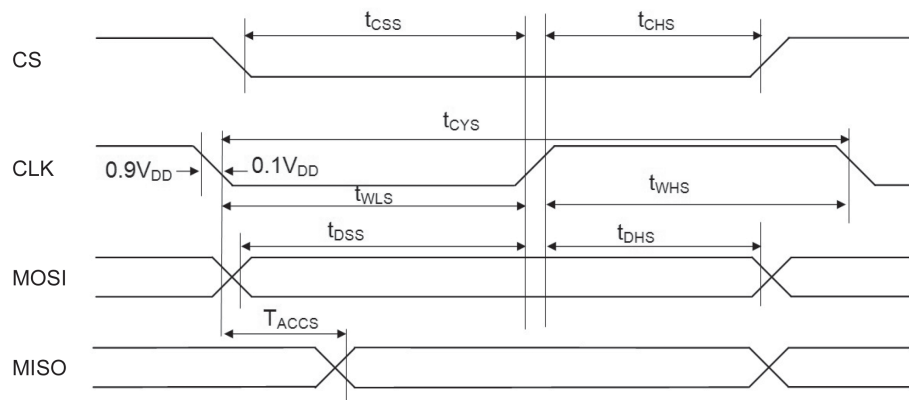

Item	Signal	Symbol	Min.	Typ.	Max.	Unit
Serial clock cycle	CLK	t_{CYS}	300	-	-	ns
SCL high pulse width	CLK	t_{WHS}	100	-	-	ns
SCL low pulse width	CLK	t_{WLS}	100	-	-	ns
CSB setup time	CS	t_{CSS}	150	-	-	ns
CSB hold time	CS	t_{CHS}	150	-	-	ns
Data setup time	MOSI	t_{DSS}	100	-	-	ns
Data hold time	MOSI	t_{DHS}	100	-	-	ns
Read access time	MOSI	t_{ACCS}	-	-	80	ns

EA W082-XLG

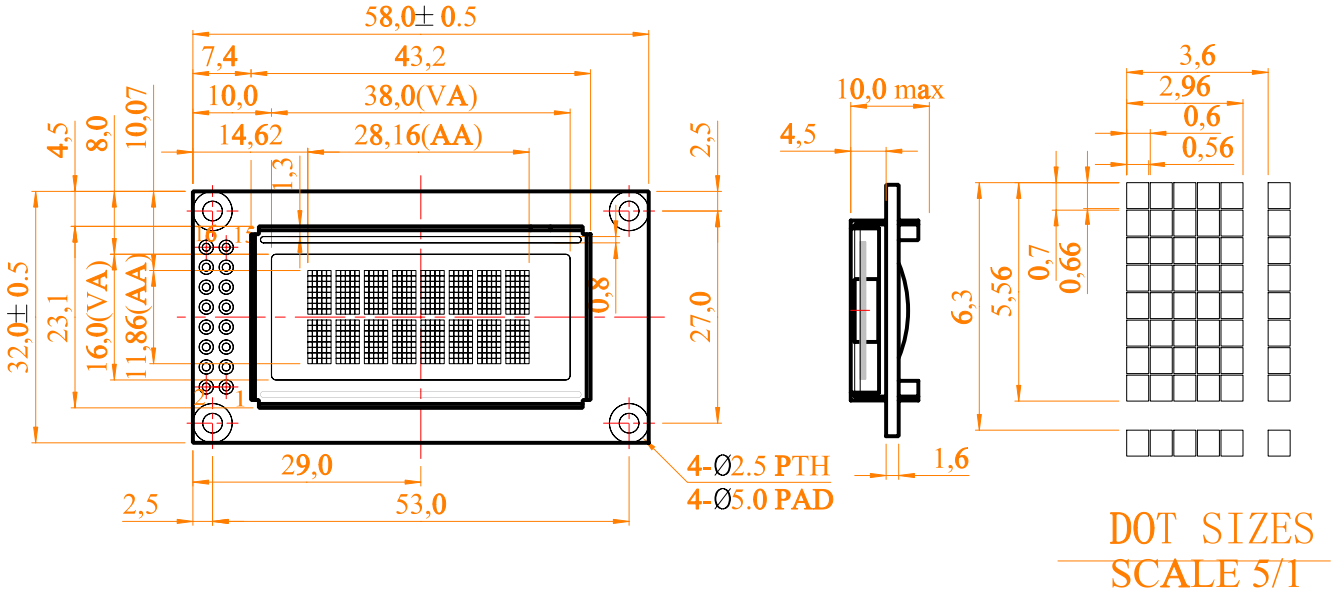

INTERFACE 4-/8-BIT, 6800/ Z80



4-/8-Bit 6800
(Voreinstellung)

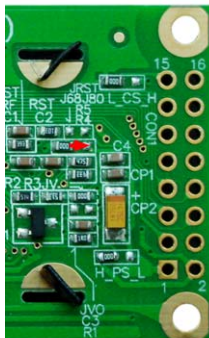

4-/8-Bit Z80

Pinout for 8-Bit Interface			
Pin	Symbol	Level	Description
1	VSS	L	Power Supply 0V, GND
2	VDD	H	Power Supply +3.3V-5V
3	NC	-	Not Connected
4	RS	H / L	Register Select
5	R/W (WR)	H / L (L)	H: Read / L: Write (L: Write, Z80-Mode)
6	E (RD)	H (L)	H: Enable (L: Read, Z80-Mode)
7..14	D0..D7	H / L	Data Bus, bidirectional
15	NC	-	Not Connected
16	NC	-	Not Connected

Pinout for 4-Bit Interface			
Pin	Symbol	Level	Description
1	VSS	L	Power Supply 0V, GND
2	VDD	H	Power Supply +3.3V-5V
3	NC	-	Not Connected
4	RS	H / L	Register Select
5	R/W (WR)	H / L (L)	H: Read / L: Write (L: Write, Z80-Mode)
6	E (RD)	H (L)	H: Enable (L: Read, Z80-Mode)
7..10	DNC	-	Do Not Connect
11..14	D4..D7	H / L	Data Bus, bidirectional
15	NC	-	Not Connected
16	NC	-	Not Connected

SPI INTERFACE

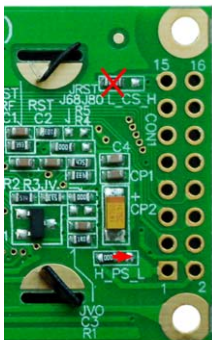

SPI

Pinout for SPI-Interface			
Pin	Symbol	Level	Description
1	VSS	L	Power Supply 0V, GND
2	VDD	H	Power Supply +3.3V-5V
3..11	NC	-	Not Connected
12	CLK	H / L	L-H: Serial Clock
13	MISO	H / L	Serial Data Output
14	MOSI	H / L	Serial Data Input
15	CS	L	L: Chip Select
16	NC	-	Not Connected

Im Auslieferungszustand kann das Display direkt an einen 4- oder 8-Bit Datenbus angeschlossen werden (kompatibel zum 6800 Mode). Durch Ändern von Lötbrücken kann der Mode auf „Z80“ umgestellt werden. Weiterhin ist auch ein Betrieb an einer SPI Schnittstelle möglich.

Informationen zum Timing finden Sie auf den Seiten 6 und 7.

EA W162-X3LW (ICEWHITE)
EA W162-X3LG (GELB/GRÜN)

RAHMEN
EA 017-2U

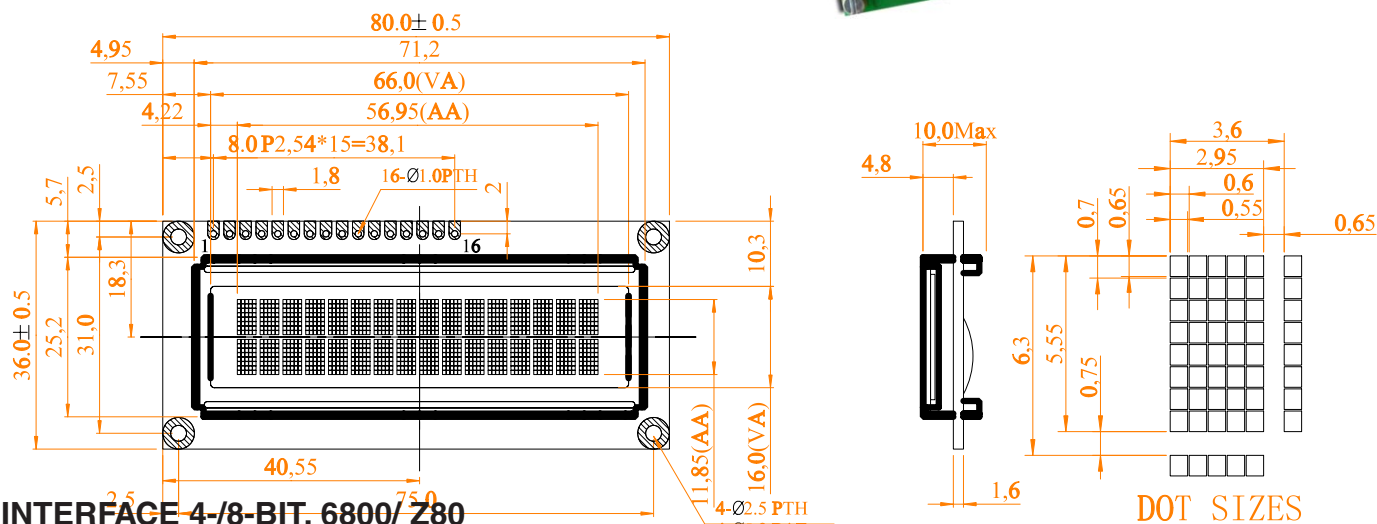
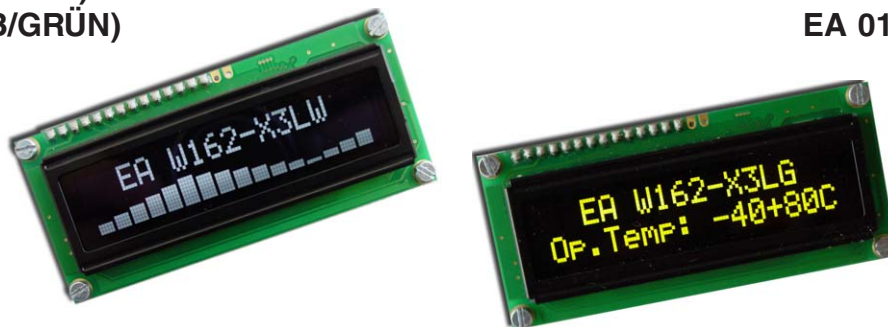

INTERFACE 4-/8-BIT, 6800/ Z80



4-/8-Bit 6800 (default)

4-/8-Bit Z80

Pinout for 8-Bit Interface			
Pin	Symbol	Level	Description
1	VSS	L	Power Supply 0V, GND
2	VDD	H	Power Supply +3.3V-5V
3	NC	-	Not Connected
4	RS	H / L	Register Select
5	R/W (WR)	H / L (L)	H: Read / L: Write (L: Write, Z80-Mode)
6	E (RD)	H (L)	H: Enable (L: Read, Z80-Mode)
7..14	D0..D7	H / L	Data Bus, bidirectional
15	NC	-	Not Connected
16	NC	-	Not Connected

Pinout for 4-Bit Interface			
Pin	Symbol	Level	Description
1	VSS	L	Power Supply 0V, GND
2	VDD	H	Power Supply +3.3V-5V
3	NC	-	Not Connected
4	RS	H / L	Register Select
5	R/W (WR)	H / L (L)	H: Read / L: Write (L: Write, Z80-Mode)
6	E (RD)	H (L)	H: Enable (L: Read, Z80-Mode)
7..10	DNC	-	Do Not Connect
11..14	D4..D7	H / L	Data Bus, bidirectional
15	NC	-	Not Connected
16	NC	-	Not Connected

SPI INTERFACE



SPI

Pinout for SPI-Bit Interface			
Pin	Symbol	Level	Description
1	VSS	L	Power Supply 0V, GND
2	VDD	H	Power Supply +3.3V-5V
3..11	NC	-	Not Connected
12	CLK	H / L	L-H: Serial Clock
13	MISO	H / L	Serial Data Output
14	MOSI	H / L	Serial Data Input
15	NC	-	Not Connected
16	CS	L	L: Chip Select

Im Auslieferungszustand kann das Display direkt an einen 4- oder 8-Bit Datenbus angeschlossen werden (kompatibel zum 6800 Mode). Durch Ändern von Lötbrücken kann der Mode auf „Z80“ umgestellt werden. Weiterhin ist auch ein Betrieb an einer SPI Schnittstelle möglich.

Informationen zum Timing finden Sie auf den Seiten 6 und 7.

EA W162-XLG (GELB/GRÜN)

RAHMEN EA 017-2U

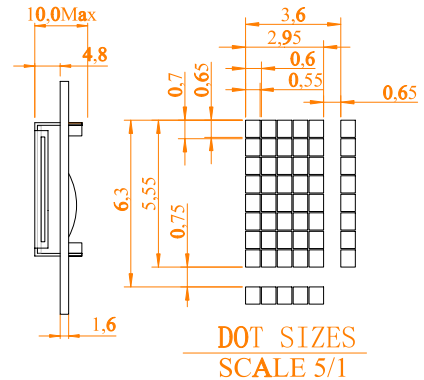
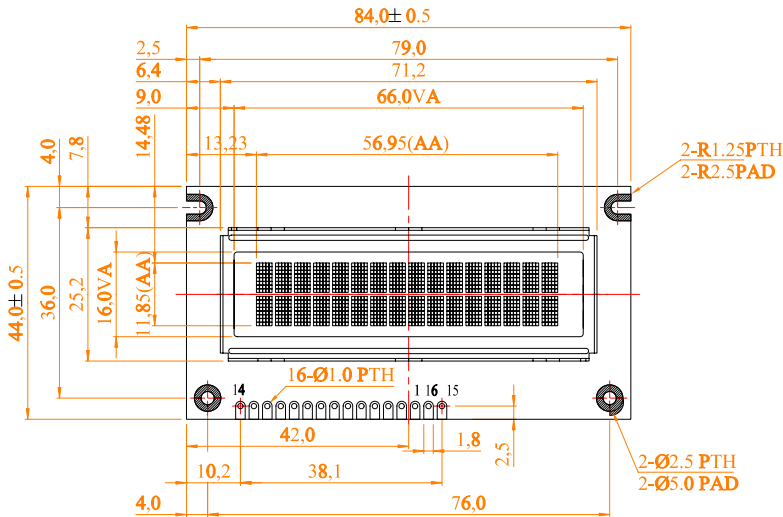

INTERFACE 4-/8-BIT, 6800/ Z80



4-/8-Bit 6800
(Voreinstellung)



4-/8-Bit Z80

Pinout for 8-Bit Interface			
Pin	Symbol	Level	Description
1	VSS	L	Power Supply 0V, GND
2	VDD	H	Power Supply +3.3V-5V
3	NC	-	Not Connected
4	RS	H / L	Register Select
5	R/W (WR)	H / L (L)	H: Read / L: Write (L: Write, Z80-Mode)
6	E (RD)	H (L)	H: Enable (L: Read, Z80-Mode)
7..14	D0..D7	H / L	Data Bus, bidirectional
15	NC	-	Not Connected
16	NC	-	Not Connected

Pinout for 4-Bit Interface			
Pin	Symbol	Level	Description
1	VSS	L	Power Supply 0V, GND
2	VDD	H	Power Supply +3.3V-5V
3	NC	-	Not Connected
4	RS	H / L	Register Select
5	R/W (WR)	H / L (L)	H: Read / L: Write (L: Write, Z80-Mode)
6	E (RD)	H (L)	H: Enable (L: Read, Z80-Mode)
7..10	DNC	-	Do Not Connect
11..14	D4..D7	H / L	Data Bus, bidirectional
15	NC	-	Not Connected
16	NC	-	Not Connected

SPI INTERFACE



SPI

Pinout for SPI-Interface			
Pin	Symbol	Level	Description
1	VSS	L	Power Supply 0V, GND
2	VDD	H	Power Supply +3.3V-5V
3..11	NC	-	Not Connected
12	CLK	H / L	L-H: Serial Clock
13	MISO	H / L	Serial Data Output
14	MOSI	H / L	Serial Data Input
15	NC	-	Not Connected
16	CS	L	L: Chip Select

Im Auslieferungszustand kann das Display direkt an einen 4- oder 8-Bit Datenbus angeschlossen werden (kompatibel zum 6800 Mode). Durch Ändern von Lötbrücken kann der Mode auf „Z80“ umgestellt werden. Weiterhin ist auch ein Betrieb an einer SPI Schnittstelle möglich.

Informationen zum Timing finden Sie auf den Seiten 6 und 7.

EA W162-X9LG

RAHMEN EA 017-2U

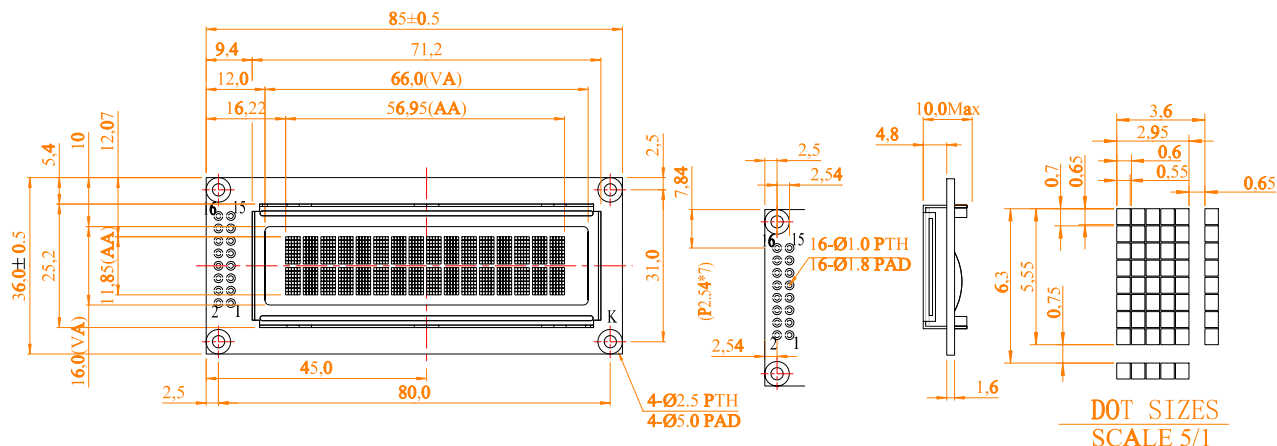

INTERFACE 4-/8-BIT, 6800/ Z80



4-/8-Bit 6800
(Voreinstellung)



4-/8-Bit Z80

Pinout for 8-Bit Interface			
Pin	Symbol	Level	Description
1	VSS	L	Power Supply 0V, GND
2	VDD	H	Power Supply +3.3V-5V
3	NC	-	Not Connected
4	RS	H / L	Register Select
5	R/W (WR)	H / L (L)	H: Read / L: Write (L: Write, Z80-Mode)
6	E (RD)	H (L)	H: Enable (L: Read, Z80-Mode)
7..14	D0..D7	H / L	Data Bus, bidirectional
15	NC	-	Not Connected
16	NC	-	Not Connected

Pinout for 4-Bit Interface			
Pin	Symbol	Level	Description
1	VSS	L	Power Supply 0V, GND
2	VDD	H	Power Supply +3.3V-5V
3	NC	-	Not Connected
4	RS	H / L	Register Select
5	R/W (WR)	H / L (L)	H: Read / L: Write (L: Write, Z80-Mode)
6	E (RD)	H (L)	H: Enable (L: Read, Z80-Mode)
7..10	DNC	-	Do Not Connect
11..14	D4..D7	H / L	Data Bus, bidirectional
15	NC	-	Not Connected
16	NC	-	Not Connected

SPI INTERFACE

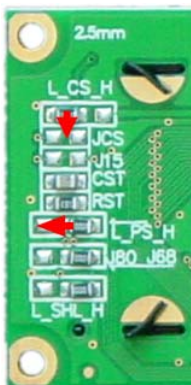

SPI

Pinout for SPI-Interface			
Pin	Symbol	Level	Description
1	VSS	L	Power Supply 0V, GND
2	VDD	H	Power Supply +3.3V-5V
3..11	NC	-	Not Connected
12	CLK	H / L	L-H: Serial Clock
13	MISO	H / L	Serial Data Output
14	MOSI	H / L	Serial Data Input
15	NC	-	Not Connected
16	CS	L	L: Chip Select

Im Auslieferungszustand kann das Display direkt an einen 4- oder 8-Bit Datenbus angeschlossen werden (kompatibel zum 6800 Mode). Durch Ändern von Lötbrücken kann der Mode auf „Z80“ umgestellt werden. Weiterhin ist auch ein Betrieb an einer SPI Schnittstelle möglich.

Informationen zum Timing finden Sie auf den Seiten 6 und 7.

EA W162-XBLW (ICEWHITE)
EA W162-XBLG (GELB/GRÜN)

RAHMEN
EA 017-12U

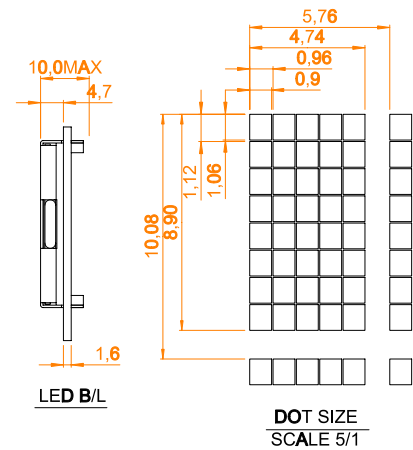
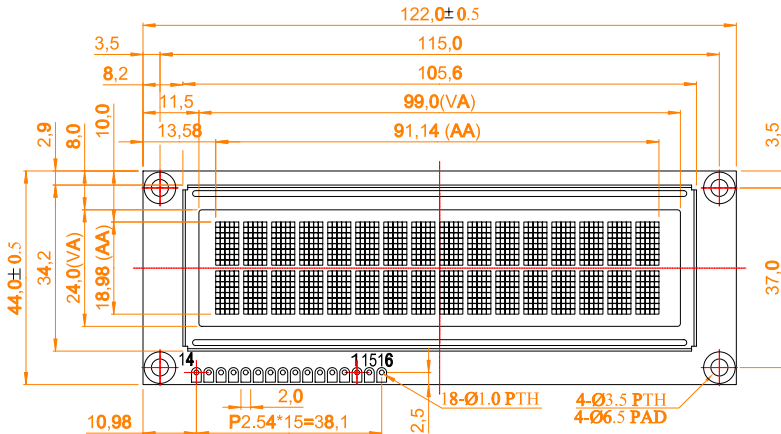

INTERFACE 4-/8-BIT, 6800/ Z80

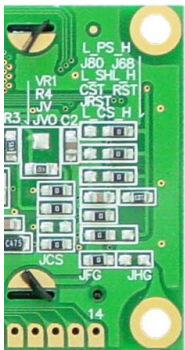

4-/8-Bit 6800
(Voreinstellung)

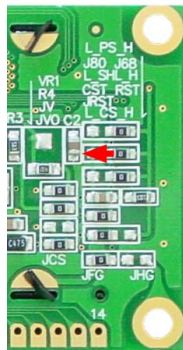

4-/8-Bit Z80

Pinout for 8-Bit Interface			
Pin	Symbol	Level	Description
1	VSS	L	Power Supply 0V, GND
2	VDD	H	Power Supply +3.3V-5V
3	NC	-	Not Connected
4	RS	H / L	Register Select
5	R/W (WR)	H / L (L)	H: Read / L: Write (L: Write, Z80-Mode)
6	E (RD)	H (L)	H: Enable (L: Read, Z80-Mode)
7..14	D0..D7	H / L	Data Bus, bidirectional
15	NC	-	Not Connected
16	NC	-	Not Connected

Pinout for 4-Bit Interface			
Pin	Symbol	Level	Description
1	VSS	L	Power Supply 0V, GND
2	VDD	H	Power Supply +3.3V-5V
3	NC	-	Not Connected
4	RS	H / L	Register Select
5	R/W (WR)	H / L (L)	H: Read / L: Write (L: Write, Z80-Mode)
6	E (RD)	H (L)	H: Enable (L: Read, Z80-Mode)
7..10	DNC	-	Do Not Connect
11..14	D4..D7	H / L	Data Bus, bidirectional
15	NC	-	Not Connected
16	NC	-	Not Connected

SPI INTERFACE

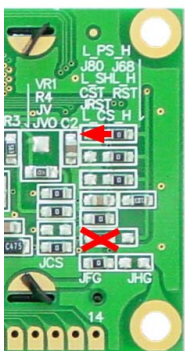

SPI

Pinout for SPI-Interface			
Pin	Symbol	Level	Description
1	VSS	L	Power Supply 0V, GND
2	VDD	H	Power Supply +3.3V-5V
3..11	NC	-	Not Connected
12	CLK	H / L	L-H: Serial Clock
13	MISO	H / L	Serial Data Output
14	MOSI	H / L	Serial Data Input
15	NC	-	Not Connected
16	CS	L	L: Chip Select

Im Auslieferungszustand kann das Display direkt an einen 4- oder 8-Bit Datenbus angeschlossen werden (kompatibel zum 6800 Mode). Durch Ändern von Lötbrücken kann der Mode auf „Z80“ umgestellt werden. Weiterhin ist auch ein Betrieb an einer SPI Schnittstelle möglich.

Informationen zum Timing finden Sie auf den Seiten 6 und 7.

EA W202-XLG

RAHMEN
EA 017-7U

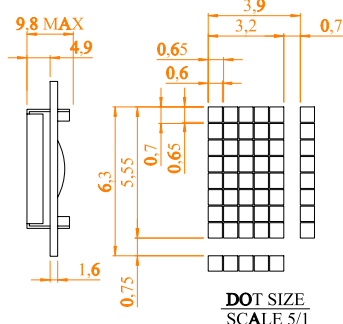
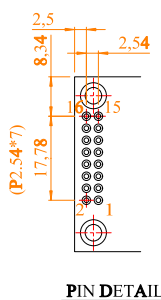
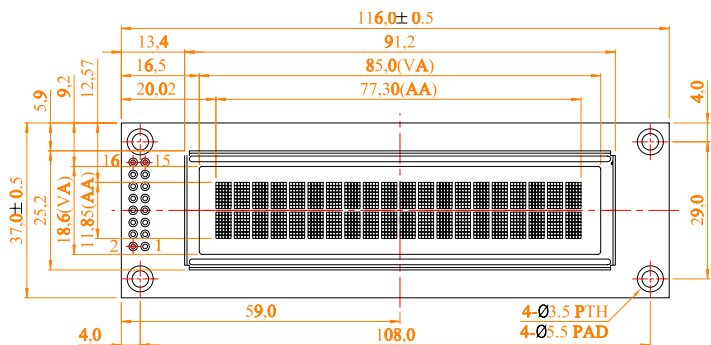

INTERFACE 4-/8-BIT, 6800/ Z80



4-/8-Bit 6800
(Voreinstellung)



4-/8-Bit Z80

SPI INTERFACE



SPI

Pinout for 8-Bit Interface			
Pin	Symbol	Level	Description
1	VSS	L	Power Supply 0V, GND
2	VDD	H	Power Supply +3.3V-5V
3	NC	-	Not Connected
4	RS	H / L	Register Select
5	R/W (WR)	H / L (L)	H: Read / L: Write (L: Write, Z80-Mode)
6	E (RD)	H (L)	H: Enable (L: Read, Z80-Mode)
7..14	DO..D7	H / L	Data Bus, bidirectional
15	NC	-	Not Connected
16	NC	-	Not Connected

Pinout for 4-Bit Interface			
Pin	Symbol	Level	Description
1	VSS	L	Power Supply 0V, GND
2	VDD	H	Power Supply +3.3V-5V
3	NC	-	Not Connected
4	RS	H / L	Register Select
5	R/W (WR)	H / L (L)	H: Read / L: Write (L: Write, Z80-Mode)
6	E (RD)	H (L)	H: Enable (L: Read, Z80-Mode)
7..10	DNC	-	Do Not Connect
11..14	D4..D7	H / L	Data Bus, bidirectional
15	NC	-	Not Connected
16	NC	-	Not Connected

Pinout for SPI-Bit Interface			
Pin	Symbol	Level	Description
1	VSS	L	Power Supply 0V, GND
2	VDD	H	Power Supply +3.3V-5V
3..11	NC	-	Not Connected
12	CLK	H / L	L-H: Serial Clock
13	MISO	H / L	Serial Data Output
14	MOSI	H / L	Serial Data Input
15	NC	-	Not Connected
16	CS	L	L: Chip Select

Im Auslieferungszustand kann das Display direkt an einen 4- oder 8-Bit Datenbus angeschlossen werden (kompatibel zum 6800 Mode). Durch Ändern von Lötbrücken kann der Mode auf „Z80“ umgestellt werden. Weiterhin ist auch ein Betrieb an einer SPI Schnittstelle möglich.

Informationen zum Timing finden Sie auf den Seiten 6 und 7.

EA W202-XDLG

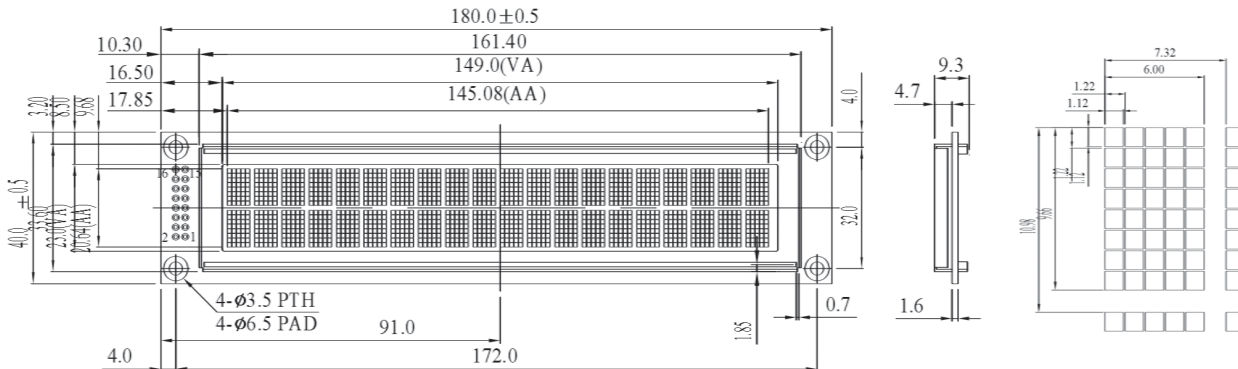

INTERFACE 4-/8-BIT, 6800/ Z80

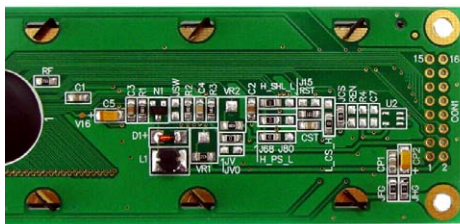

4-/8-Bit 6800
(Voreinstellung)

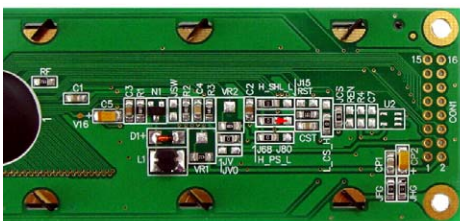

4-/8-Bit Z80

SPI INTERFACE

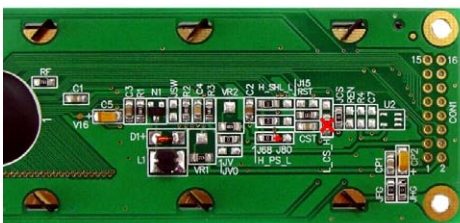

SPI

Im Auslieferungszustand kann das Display direkt an einen 4- oder 8-Bit Datenbus angeschlossen werden (kompatibel zum 6800 Mode). Durch Ändern von Lötbrücken kann der Mode auf „Z80“ umgestellt werden. Weiterhin ist auch ein Betrieb an einer SPI Schnittstelle möglich. Informationen zum Timing finden Sie auf den Seiten 6 und 7.

Pinout for 8-Bit Interface			
Pin	Symbol	Level	Description
1	VSS	L	Power Supply 0V, GND
2	VDD	H	Power Supply +3.3V-5V
3	NC	-	Not Connected
4	RS	H / L	Register Select
5	R/W (WR)	H / L (L)	H: Read / L: Write (L: Write, Z80-Mode)
6	E (RD)	H (L)	H: Enable (L: Read, Z80-Mode)
7..14	D0..D7	H / L	Data Bus, bidirectional
15	NC	-	Not Connected
16	NC	-	Not Connected

Pinout for 4-Bit Interface			
Pin	Symbol	Level	Description
1	VSS	L	Power Supply 0V, GND
2	VDD	H	Power Supply +3.3V-5V
3	NC	-	Not Connected
4	RS	H / L	Register Select
5	R/W (WR)	H / L (L)	H: Read / L: Write (L: Write, Z80-Mode)
6	E (RD)	H (L)	H: Enable (L: Read, Z80-Mode)
7..10	DNC	-	Do Not Connect
11..14	D4..D7	H / L	Data Bus, bidirectional
15	NC	-	Not Connected
16	NC	-	Not Connected

Pinout for SPI-Bit Interface			
Pin	Symbol	Level	Description
1	VSS	L	Power Supply 0V, GND
2	VDD	H	Power Supply +3.3V-5V
3..11	NC	-	Not Connected
12	CLK	H / L	L-H: Serial Clock
13	MISO	H / L	Serial Data Output
14	MOSI	H / L	Serial Data Input
15	NC	-	Not Connected
16	CS	L	L: Chip Select

EA W204-XLG



**RAHMEN
EA 017-9U**

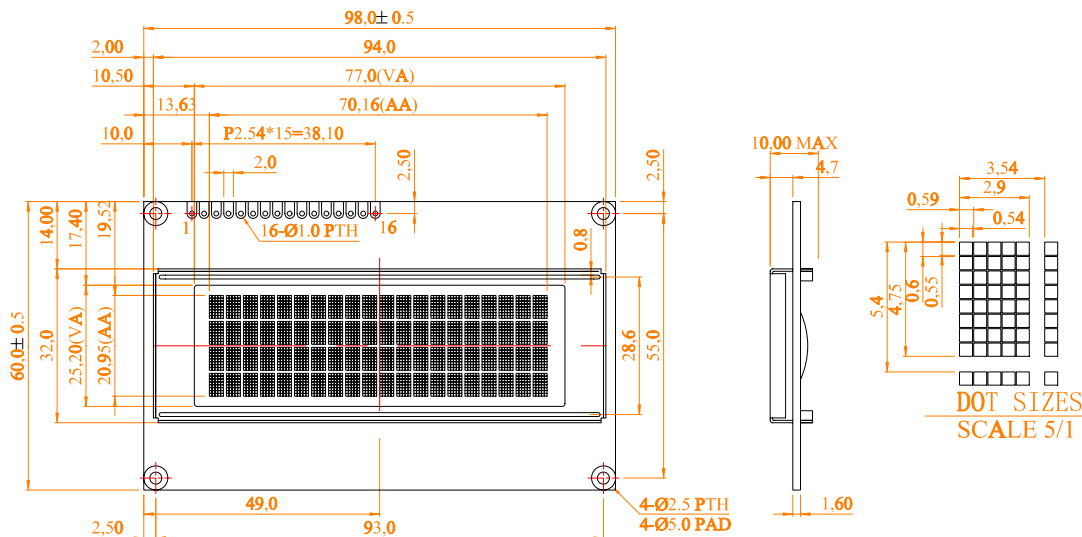

INTERFACE 4-/8-BIT, 6800/ Z80



4-/8-Bit 6800
(Voreinstellung)

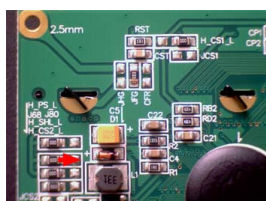

4-/8-Bit Z80

Pinout for 8-Bit Interface			
Pin	Symbol	Level	Description
1	VSS	L	Power Supply 0V, GND
2	VDD	H	Power Supply +3.3V-5V
3	NC	-	Not Connected
4	RS	H / L	Register Select
5	R/W (WR)	H / L (L)	H: Read / L: Write (L: Write, Z80-Mode)
6	E (RD)	H (L)	H: Enable (L: Read, Z80-Mode)
7..14	D0..D7	H / L	Data Bus, bidirectional
15	NC	-	Not Connected
16	NC	-	Not Connected

Pinout for 4-Bit Interface			
Pin	Symbol	Level	Description
1	VSS	L	Power Supply 0V, GND
2	VDD	H	Power Supply +3.3V-5V
3	NC	-	Not Connected
4	RS	H / L	Register Select
5	R/W (WR)	H / L (L)	H: Read / L: Write (L: Write, Z80-Mode)
6	E (RD)	H (L)	H: Enable (L: Read, Z80-Mode)
7..10	DNC	-	Do Not Connect
11..14	D4..D7	H / L	Data Bus, bidirectional
15	NC	-	Not Connected
16	NC	-	Not Connected

SPI INTERFACE

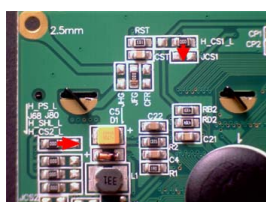

SPI

Pinout for SPI-Interface			
Pin	Symbol	Level	Description
1	VSS	L	Power Supply 0V, GND
2	VDD	H	Power Supply +3.3V-5V
3..11	NC	-	Not Connected
12	CLK	H / L	L-H: Serial Clock
13	MISO	H / L	Serial Data Output
14	MOSI	H / L	Serial Data Input
15	CS	L	L: Chip Select
16	NC	-	Not Connected

Im Auslieferungszustand kann das Display direkt an einen 4- oder 8-Bit Datenbus angeschlossen werden (kompatibel zum 6800

Mode). Durch Ändern von Lötbrücken kann der Mode auf „Z80“ umgestellt werden. Weiterhin ist auch ein Betrieb an einer SPI Schnittstelle möglich. Informationen zum Timing finden Sie auf den Seiten 6 und 7.