

# 億力光電股份有限公司

## EVERVISION ELECTRONICS CO., LTD.

### Product Specification For LCD Module

(KVPF-7B-002-16)

Model NO. : VGG106004-6UFLWA(RoHS)

REVISION : 2

APPROVAL FOR SPECIFICATIONS ONLY

APPROVAL FOR SPECIFICATIONS AND SAMPLE

CUSTOMER :

STD.

APPROVED BY :

### EVERVISION LCM R&D CENTER

APPROVED BY

CHECKED BY

PREPARED BY

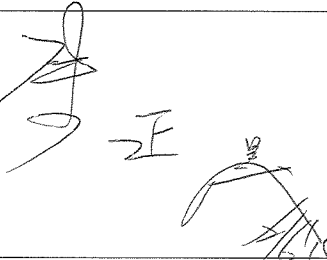

DIRECTOR

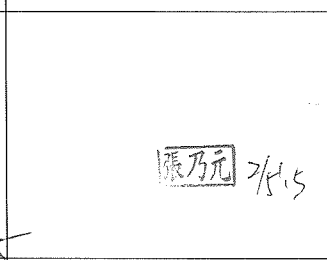

MANAGER

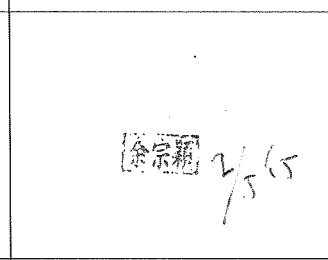

Mechanism Engineer

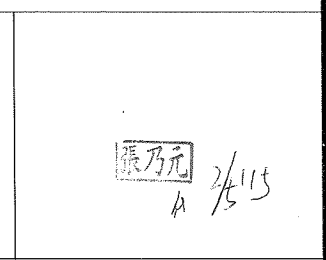

Electronic Engineer

億力光電股份有限公司總公司  
EVERVISION ELECTRONICS LTD.  
台北縣中和市建一路 186 號 12 樓  
12F, NO. 186, JIAN 1st RD., CHUNG HO CITY,  
TAIPEI HSIEN, TAIWAN, R.O.C  
TEL : +886 2 8227-2788  
FAX : +886 2 8227-2789

億力光電股份有限公司台中分公司  
EVERVISION ELECTRONICS(T.C) LTD.  
台中縣潭子鄉台中加工出口區建國路 19 號  
NO.19, CHIEN KUO ROAD. T.E.P.Z TANTZE  
427 TAICHUNG HSIEN TAIWAN R.O.C  
TEL : +886 4 2532-8889  
FAX : +886 4 2532-6689

東莞莞城德寶電子廠  
EVERVISION ELECTRONICS(B.V.I) LTD.  
廣東省東莞市城區東縱大道天寶路 9 號  
NO.9, Tian Bao Rd., Dong Zong St., Dong Guan City  
Guang Dong, China.  
TEL : +86 769 2220 5258  
FAX : +86 769 2220 7258

勁佳光電(昆山)有限公司  
EVERVISION ELECTRONICS(KUNSHAN) LTD.  
江蘇省昆山市玉山鎮高科技工業園城北路 8 號  
NO.8, Chengbei Rd., Hi-Tech Industry Park,  
Yushan Town, Kunshan City, Jiangsu, China.  
TEL : +86 512 5778 7288  
FAX : +86 512 5777 0688

<http://www.evervisionlcd.com>

<b>EVERVISION</b>	<b>MODEL NO.</b>		<b>PAGE</b>
	VGG106004-6UFLWA	SPEC & SAMPLE	2

## 1. Table of Contents

<b>No.</b>	<b>Contents</b>	<b>Page</b>
1	Table of Contents	2
2	Record of Revisions	3
3	Module Numbering System	4
4	Application	5
5	Features	5
6	General Specifications	5
7	Absolute Maximum Ratings	6
8	Electrical Characteristics	7
9	Block Diagram	9
10	Input / Output Terminals Pin Assignment	10
11	Interface Timing	14
12	Optical Characteristics	19
13	Reliability Test	22
14	Packaging	23
15	Precautions	24
16	Outline Drawing	25
17	Definition of Labels	26
18	Incoming Inspection Standards	28



<b>EVERVISION</b>	<b>MODEL NO.</b>		<b>PAGE</b>
	VGG106004-6UFLWA	SPEC & SAMPLE	4

### 3. Module Numbering System

**V G G 1060 04 - 6 U F L W A**

Serial No.: A~Z

Backlight Color:  
**N:** Without Backlight;  
**A:** Amber; **B:** Blue; **G:** Green;  
**L:** Yellow; **O:** Orange; **R:** Red;  
**W:** White; **Y:** YellowGreen;  
**X:** Others

Backlight Type:  
**N:** Without Backlight; **E:** EL; **F:** CCFL;  
**L:** General LED; **H:** High NTSC LED ;  
**R:** RGB LED; **X:** Others

LCD Model:  
**A:** ASTN; **B:** STN Blue; **C:** CSTN; **D:** DSTN;  
**F:** TFT; **G:** STN Gray; **H:** HTN; **I:** IBN;  
**K:** Black Mask TN **L:** LTPS; **M:** MVA;  
**N:** others; **O:** OLED; **P:** PLED; **S:** IPS;  
**T:** TN; **U:** FSC TN; **W:** FSTN Black/white;  
**X:** FFSTN; **Y:** STN Yellow;

LCD Type:  
**R:** Reflective/Positive;  
**S:** Reflective/Negative ;  
**F:** Transflective/Positive ;  
**G:** Transflective/Negative ;  
**U:** Transmissive/Positive ;  
**T:** Transmissive/Negative ; **N:** Others

Temperature Range & View Direction:  
 General Purpose : **1:**6H **2:**12H **3:**3H **4:**9H **5:**Others  
 High Performance: **6:**6H **7:**12H **8:**3H **9:**9H **0:**Others

STD Product Serial No.: 01~99  
 Customer Made Serial No.: A1,A2...A9,B1,B2...B9,C1..

Display Function:  
 Segment Number / Characters Lines / Column and Row Dots  
 / Length \* Width of Other

Display Type:  
**C:** Character Type; **G:** Graphic Type; **S:** Segment Type; **O:** Other

Package Type:  
**B:** COB; **F:** COF; **G:** COG; **H:** Heat Seal; **S:** SMT; **T:** TAB; **O:** Others

<b>EVERVISION</b>	<b>MODEL NO.</b>		<b>PAGE</b>
	VGG106004-6UFLWA	SPEC & SAMPLE	5

#### 4. Application

This specification is applied to the 7 inch WSVGA supported TFT-LCD module, and can display true 16.7M colors (RGB 6-bits + HiFRC data). The module is designed for OA, Car TV application and other electronic products which require flat panel display of digital signal interface. This module is composed of a 7" TFT-LCD panel, a driver circuit and backlight unit.

#### 5. Features

- WSVGA (1024×600 pixels) resolution.
- 8 bit LVDS Interface
- Dot inversion mode with stripe type.

#### 6. General Specifications

Item	Specifications	Unit
Screen Size	7 (Diagonal)	inch
Display Format	1024RGB(H)×600(V)	dot
Active Area	153.6(H)×86.64(V)	mm
Pixel Pitch	0.15(H)×0.1444(V)	mm
Pixel Configuration	RGB Vertical Stripe	-
Display Mode	TN Type Transmissive Mode Normally White	-
Surface Treatment	Antiglare, Hard-Coating(3H)	-
Viewing Direction	6 O'clock (The Gray Inversion will appear at this direction)	-
Outline Dimension	165.0(W)×104.0(H)×3.5(D)	mm
Weight	115.4	g
RoHS Compliance	Evervision certifies this product to be in compliance with European Union Directive 2011/65/EU on the restriction of certain hazardous substances in electrical and electronic equipment.	-

<b>EVERVISION</b>	<b>MODEL NO.</b>		<b>PAGE</b>
	VGG106004-6UFLWA	SPEC & SAMPLE	6

## 7. Absolute Maximum Ratings

### 7.1 Absolute Ratings of Environment

Item	Symbol	Value		Unit	Note
		Min.	Max.		
Storage Temperature	T <sub>ST</sub>	-30	+80	°C	(1)(2)
Operating Ambient Temperature	T <sub>OP</sub>	-20	+70	°C	(1)(2)

Note1: Background color changes slightly depending on ambient temperature.

This phenomenon is reversible.

Note2: Please refer to item of RELIABILITY.

### 7.2 Electrical Absolute Ratings

#### 7.2.1 TFT-LCD Module

(Ta=25±2°C)

Item	Symbol	Value		Unit	Note
		Min.	Max.		
Digital Power Supply Voltage	DV <sub>DD</sub>	-0.3	5.0	V	-
Analog Power Supply Voltage	AV <sub>DD</sub>	6.5	13.5	V	-
Gate High Voltage	V <sub>GH</sub>	-0.3	40	V	-
Gate Low Voltage	V <sub>GL</sub>	-20.0	0.3	V	-
Gate High To Gate Low Voltage	V <sub>GH</sub> - V <sub>GL</sub>	-	40	V	-

#### 7.2.2 Backlight Unit

(Ta=25±2°C)

Item	Symbol	Value		Unit	Note
		Min.	Max.		
LED Reverse Voltage	VR	-	5	V	Each LED
LED Forward Current	IF	-	30	mA	Each LED
Current of Backlight Unit	I <sub>B</sub>	-	210	mA	(1)
Voltage of Backlight Unit	V <sub>B</sub>	-	20	V	(1)

Note (1) Permanent damage to the device may occur if maximum values are exceeded or reverse voltage is loaded.

<b>EVERVISION</b>	<b>MODEL NO.</b>		<b>PAGE</b>
	VGG106004-6UFLWA	SPEC & SAMPLE	7

## 8. Electrical Characteristics

### 8.1 TFT-LCD Module

(Ta=25±2°C)

Item	Symbol	Value			Unit	Note
		Min.	Typ.	Max.		
Digital Power Supply Voltage	V <sub>DD</sub>	3.0	3.3	3.6	V	-
Analog Power Supply Voltage	AV <sub>DD</sub>	9.2	9.5	9.8	V	-
Gate High Voltage	V <sub>GH</sub>	17.7	18	18.3	V	-
Gate Low Voltage	V <sub>GL</sub>	-10.3	-10	-9.7	V	-
Input signal voltage	V <sub>COM</sub>	1.98	2.38	2.78	V	(3)
Input logic high voltage	V <sub>IH</sub>	0.7 VDD	-	VDD	V	(2)
Input logic low voltage	V <sub>IL</sub>	0	-	0.3 VDD	V	
Gate High Voltage Current	I <sub>GH</sub>	-	0.31	0.62	mA	(1)
Gate Low Voltage Current	I <sub>GL</sub>	-	1.0	2.0	mA	(1)
Digital Power Supply Current	IDD	-	33	66	mA	(1)
Analog Power Supply Current	IA <sub>DD</sub>	-	18	36	mA	(1)
signal voltage Current	ICOM	-	2.0	4.0	mA	(1)
Differential Input High Threshold Voltage	RX <sub>VTH</sub>	-	-	0.1	V	RXVCM=1.2V
Differential Input Low Threshold Voltage	RX <sub>VTL</sub>	-0.1	-	-	V	
Input voltage range (singled-end)	RxVIN	0	-	2.4	V	-
Differential input common mode voltage	RxVCM	VID /2	-	2.4 -  VID /2	V	-
Differential voltage	VID	0.2	-	0.6	V	-
Differential input leakage current	RVxliz	-10	-	+10	uA	-
DCLK Frequency	DCLK	-	51.2	-	MHz	-

Note (1) The specified power consumption is under the conditions at V<sub>DD</sub> =3.3V, DCLK =51.2MHz, whereas a power dissipation check pattern below is displayed.

Note (2): LVDS, Reset.

Note (3): Typ. VCOM is only a reference value, it must be optimized according to each LCM. Be sure to use VR;

Black Pattern / 0 Gray

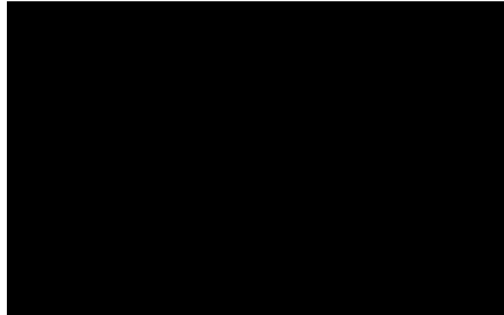

Active Area

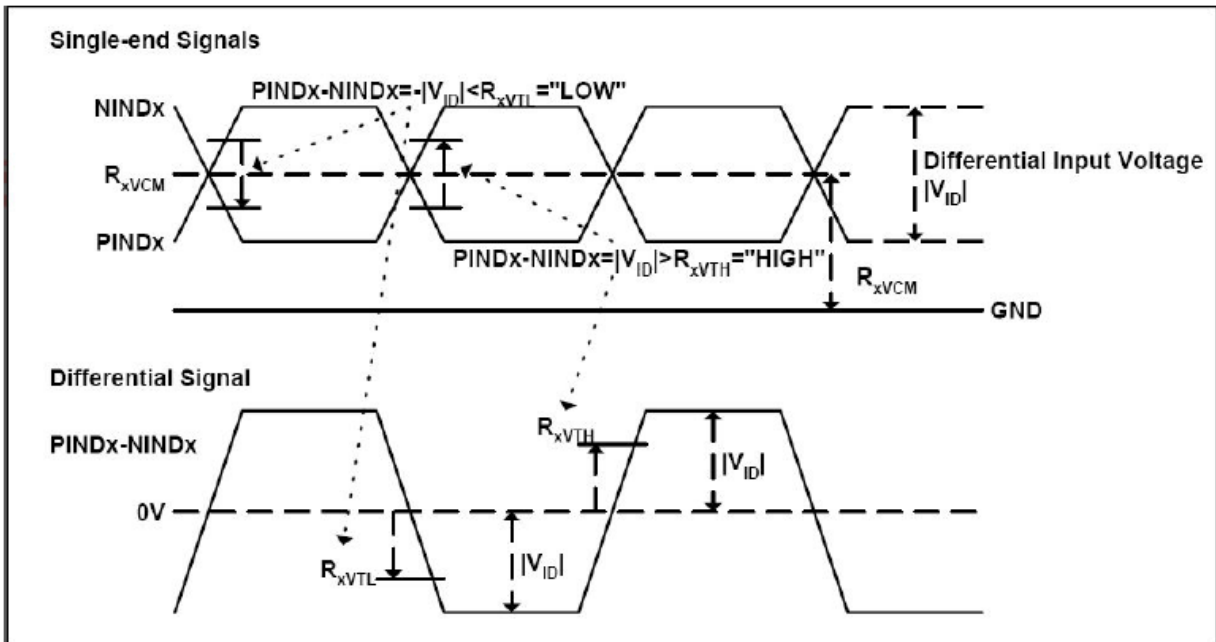

**8.2 Backlight Unit**

(Ta=25±2°C)

Item	Symbol	Value			Unit	Note
		Min.	Typ.	Max.		
Voltage of Backlight Unit	V <sub>B</sub>	-	12.8	13.6	V	-
Current of Backlight Unit	I <sub>B</sub>	-	140	-	mA	(2)
LED Life Time(25°C)	-	50000	-	-	hr	(1)(2)

Note (1) LED life time (Hr) can be defined as the time in which it continues to operate under the condition: Ta=25±3 °C, typical IL value indicated in the above table until the brightness becomes less than 50%.

Note (2) The “LED life time” is defined as the module brightness decrease to 50% original brightness at Ta=25°C and IL=140mA. The LED lifetime could be decreased if operating IL is larger than 140mA. The constant current driving method is suggested.



**9. Block Diagram**

**9.1 TFT-LCD Module with Backlight Unit**

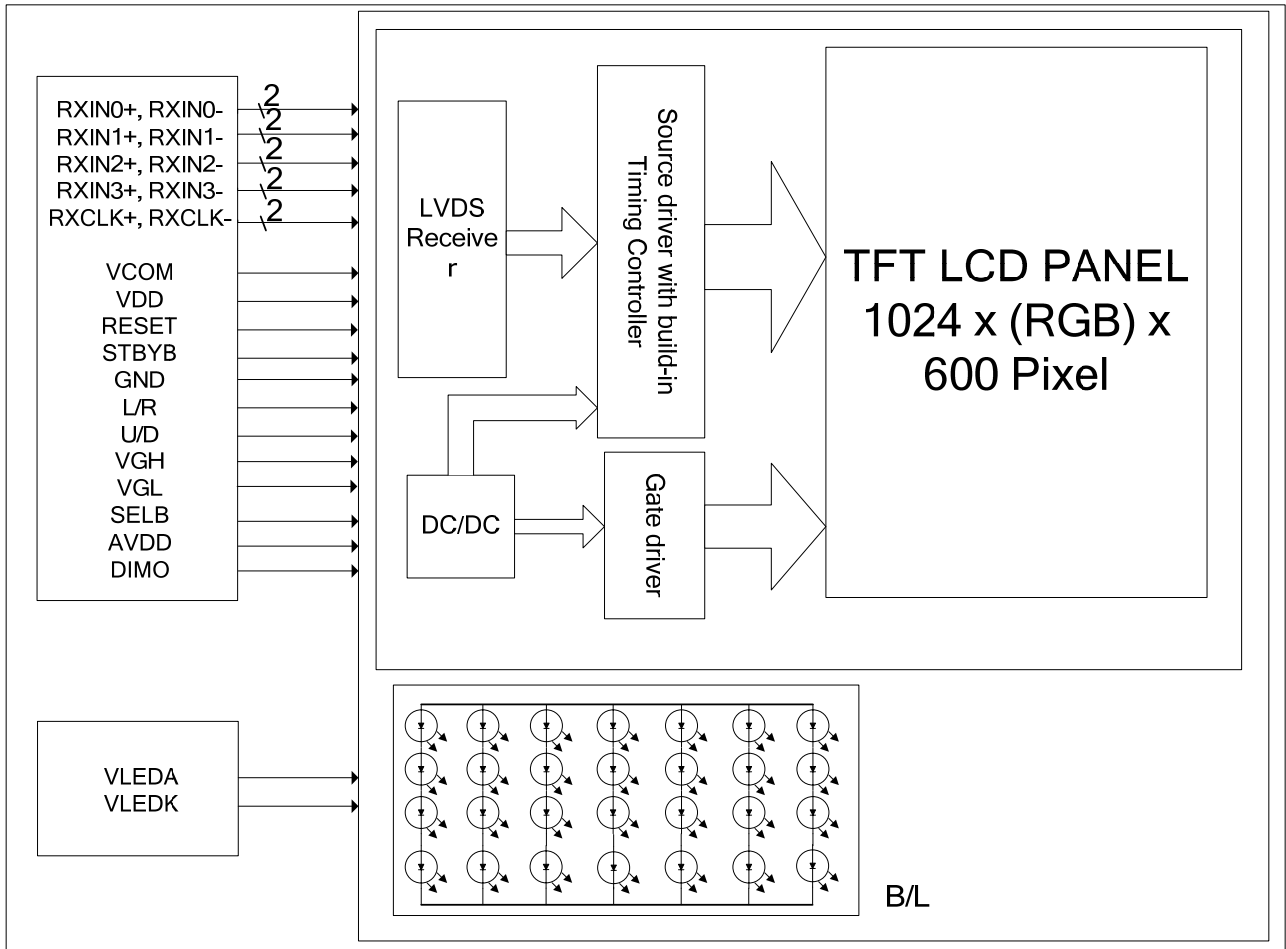

<b>EVERVISION</b>	<b>MODEL NO.</b>		<b>PAGE</b>
	VGG106004-6UFLWA	SPEC & SAMPLE	10

## 10. Input / Output Terminals Pin Assignment

### 10.1 TFT-LCD Module

FPC Connector is used for the module electronics interface. The recommended model is FH12A-40S-0.5SH manufactured by Hirose.

Pin No.	Symbol	I/O	Function	Remark
1	VCOM	P	Common Voltage	
2	VDD	P	Power Voltage for digital circuit	
3	VDD	P	Power Voltage for digital circuit	
4	NC	---	No connection	
5	Reset	I	Global reset pin	
6	STBYB	I	Standby mode, Normally pulled high STBYB = "1", normal operation STBYB = "0", timing controller, source driver will turn off, all output are High-Z	
7	GND	P	Ground	
8	RXIN0-	I	- LVDS differential data input	
9	RXIN0+	I	+ LVDS differential data input	
10	GND	P	Ground	
11	RXIN1-	I	- LVDS differential data input	
12	RXIN1+	I	+ LVDS differential data input	
13	GND	P	Ground	
14	RXIN2-	I	- LVDS differential data input	
15	RXIN2+	I	+ LVDS differential data input	
16	GND	P	Ground	
17	RXCLKIN-	I	- LVDS differential clock input	
18	RXCLKIN+	I	+ LVDS differential clock input	
19	GND	P	Ground	
20	RXIN3-	I	- LVDS differential data input	
21	RXIN3+	I	+ LVDS differential data input	
22	GND	P	Ground	

<b>EVERVISION</b>	<b>MODEL NO.</b>		<b>PAGE</b>
	VGG106004-6UFLWA	SPEC & SAMPLE	11

23	NC	---	No connection	
24	NC	---	No connection	
25	GND	P	Ground	
26	NC	---	No connection	
27	DIMO	O	Backlight CABC controller signal output	
28	SELB	I	6bit/8bit mode select	Note1
29	AVDD	P	Power for Analog Circuit	
30	GND	P	Ground	
31	LED-	P	No connection	
32	LED-	P	No connection	
33	L/R	I	Horizontal inversion	Note3
34	U/D	I	Vertical inversion	Note3
35	VGL	P	Gate OFF Voltage	
36	NC		No connector	
37	NC		No connector	
38	VGH	P	Gate ON Voltage	
39	LED+	P	No connection	
40	LED+	P	No connection	

**I: input O: Output P: Power**

**Note1: Global reset pin: Active low to enter reset mode. Suggest connecting with an RC reset circuit for**

**stability. Normally pull high. (R=10KΩ, C=0.1μF)**

**Note1: If RC is not added, users must follow the rule, T2 > 50ms on page 18 item 6.5 power on/off sequence.**

**Note2: If LVDS input data is 6 bits ,SELB must be set to High;**

**If LVDS input data is 8 bits, SELB must be set to Low.**

**Note3: When L/R=" 0" , set right to left scan direction.**

**When L/R="1", set left to right scan direction.**

**When U/D="0", set top to bottom scan direction.**

**When U/D="1", set bottom to top scan direction.**

<b>EVERVISION</b>	<b>MODEL NO.</b>		<b>PAGE</b>
	VGG106004-6UFLWA	SPEC & SAMPLE	12

## 10.2 Backlight Unit

Connector: JST BHSR-02VS-1(N)

Pin No.	Symbol	I/O	Description	Wire Color
1	VLEDA	I	Backlight LED Anode.	Red
2	VLEDC	I	Backlight LED Cathode.	Black

### 10.3 Color Data Input Assignment

The brightness of each primary color(red, green and blue) is based on the 8 bit gray scale data input for the color. The higher the binary input, the brighter the color. The table provides the assignment of color versus data input.

Color		Data Signal																							
		Red								Green								Blue							
		R7	R6	R5	R4	R3	R2	R1	R0	G7	G6	G5	G4	G3	G2	G1	G0	B7	B6	B5	B4	B3	B2	B1	B0
Basic Colors	Black	0	0	0	0	0	0	0	0	0	0	0	0	0	0	0	0	0	0	0	0	0	0	0	
	Red	1	1	1	1	1	1	1	1	0	0	0	0	0	0	0	0	0	0	0	0	0	0	0	
	Green	0	0	0	0	0	0	0	0	1	1	1	1	1	1	1	1	0	0	0	0	0	0	0	
	Blue	0	0	0	0	0	0	0	0	0	0	0	0	0	0	0	0	1	1	1	1	1	1	1	
	Cyan	0	0	0	0	0	0	0	0	1	1	1	1	1	1	1	1	1	1	1	1	1	1	1	
	Magenta	1	1	1	1	1	1	1	1	0	0	0	0	0	0	0	0	1	1	1	1	1	1	1	
	Yellow	1	1	1	1	1	1	1	1	1	1	1	1	1	1	1	1	0	0	0	0	0	0	0	
	White	1	1	1	1	1	1	1	1	1	1	1	1	1	1	1	1	1	1	1	1	1	1	1	
Gray Scale Of RED	Red(0) / Dark	0	0	0	0	0	0	0	0	0	0	0	0	0	0	0	0	0	0	0	0	0	0		
	Red(1)	0	0	0	0	0	0	0	1	0	0	0	0	0	0	0	0	0	0	0	0	0	0		
	Red(2)	0	0	0	0	0	0	0	1	0	0	0	0	0	0	0	0	0	0	0	0	0	0		
	:	:	:	:	:	:	:	:	:	:	:	:	:	:	:	:	:	:	:	:	:	:	:		
	:	:	:	:	:	:	:	:	:	:	:	:	:	:	:	:	:	:	:	:	:	:	:		
	Red(253)	1	1	1	1	1	1	0	1	0	0	0	0	0	0	0	0	0	0	0	0	0	0		
	Red(254)	1	1	1	1	1	1	1	0	0	0	0	0	0	0	0	0	0	0	0	0	0	0		
	Red(255)	1	1	1	1	1	1	1	1	0	0	0	0	0	0	0	0	0	0	0	0	0	0		
Gray Scale Of Green	Green(0) / Dark	0	0	0	0	0	0	0	0	0	0	0	0	0	0	0	0	0	0	0	0	0	0		
	Green(1)	0	0	0	0	0	0	0	0	0	0	0	0	0	0	1	0	0	0	0	0	0	0		
	Green(2)	0	0	0	0	0	0	0	0	0	0	0	0	0	1	0	0	0	0	0	0	0	0		
	:	:	:	:	:	:	:	:	:	:	:	:	:	:	:	:	:	:	:	:	:	:	:		
	:	:	:	:	:	:	:	:	:	:	:	:	:	:	:	:	:	:	:	:	:	:	:		
	Green(253)	0	0	0	0	0	0	0	0	1	1	1	1	1	1	0	1	0	0	0	0	0	0		
	Green(254)	0	0	0	0	0	0	0	0	1	1	1	1	1	1	1	0	0	0	0	0	0	0		
	Green(255)	0	0	0	0	0	0	0	0	1	1	1	1	1	1	1	1	0	0	0	0	0	0		
Gray Scale Of Blue	Blue(0) / Dark	0	0	0	0	0	0	0	0	0	0	0	0	0	0	0	0	0	0	0	0	0	0		
	Blue(1)	0	0	0	0	0	0	0	0	0	0	0	0	0	0	0	0	0	0	0	0	0	1		
	Blue(2)	0	0	0	0	0	0	0	0	0	0	0	0	0	0	0	0	0	0	0	0	0	1		
	:	:	:	:	:	:	:	:	:	:	:	:	:	:	:	:	:	:	:	:	:	:	:		
	:	:	:	:	:	:	:	:	:	:	:	:	:	:	:	:	:	:	:	:	:	:	:		
	Blue(253)	0	0	0	0	0	0	0	0	0	0	0	0	0	0	0	1	1	1	1	1	1	0		
	Blue(254)	0	0	0	0	0	0	0	0	0	0	0	0	0	0	0	1	1	1	1	1	1	0		
	Blue(255)	0	0	0	0	0	0	0	0	0	0	0	0	0	0	0	1	1	1	1	1	1	1		

**11. Interface Timing**

**11.1 Input Signal Characteristics**

**11.1.1.AC Electrical Characteristics**

Parameter	Symbol	Values			Unit	Remark
		Min.	Typ.	Max.		
Clock frequency	$R_{xFCLK}$	40.8	51.2	67.2	MHz	
Input data skew margin	$T_{RSKM}$	500	-	-	ps	
Clock high time	$T_{LVCH}$	-	$4/(7 * R_{xFCLK})$	-	ns	
Clock low time	$T_{LVCL}$	-	$3/(7 * R_{xFCLK})$	-	ns	

**11.1.2. Input Clock and Data Timing Diagram**

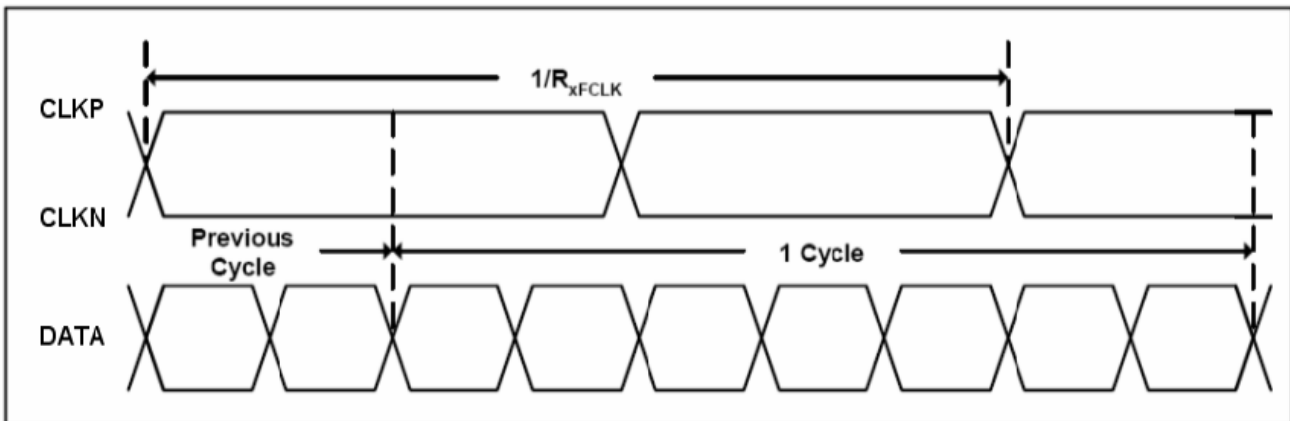

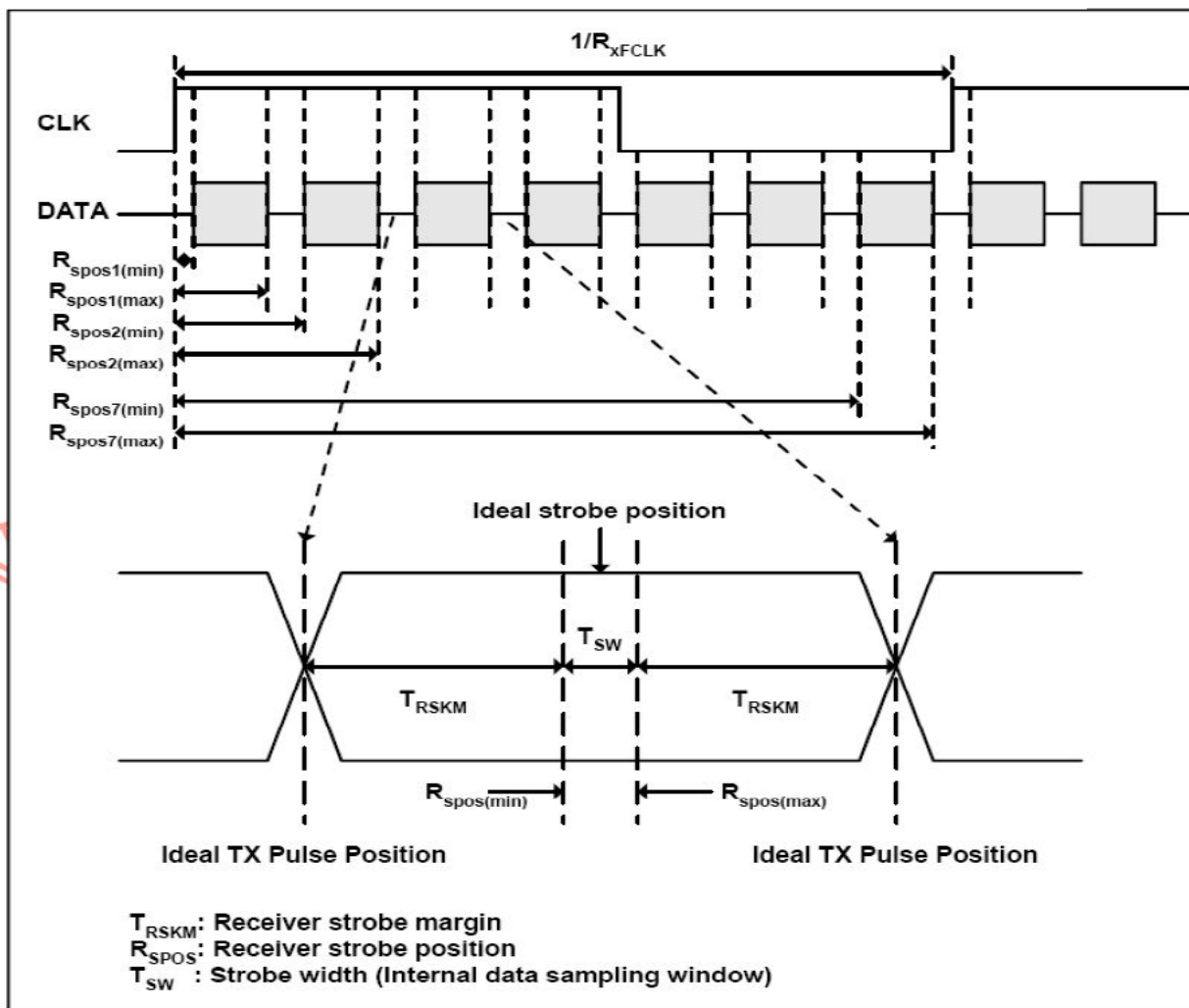

**11.1.3. Timing**

Item	Symbol	Values			Unit	Remark
		Min.	Typ.	Max.		
Clock Frequency	fclk	40.8	51.2	67.2	MHz	Frame rate =60Hz
Horizontal display area	thd	1024			DCLK	
HS period time	th	1114	1344	1400	DCLK	
HS Blanking	thb	90	320	376	DCLK	
Vertical display area	tvd	600			H	
VS period time	tv	610	635	800	H	
VS Blanking	thb	10	35	200	H	

**11.1.4. Data Input Format**

**6bit LVDS input**

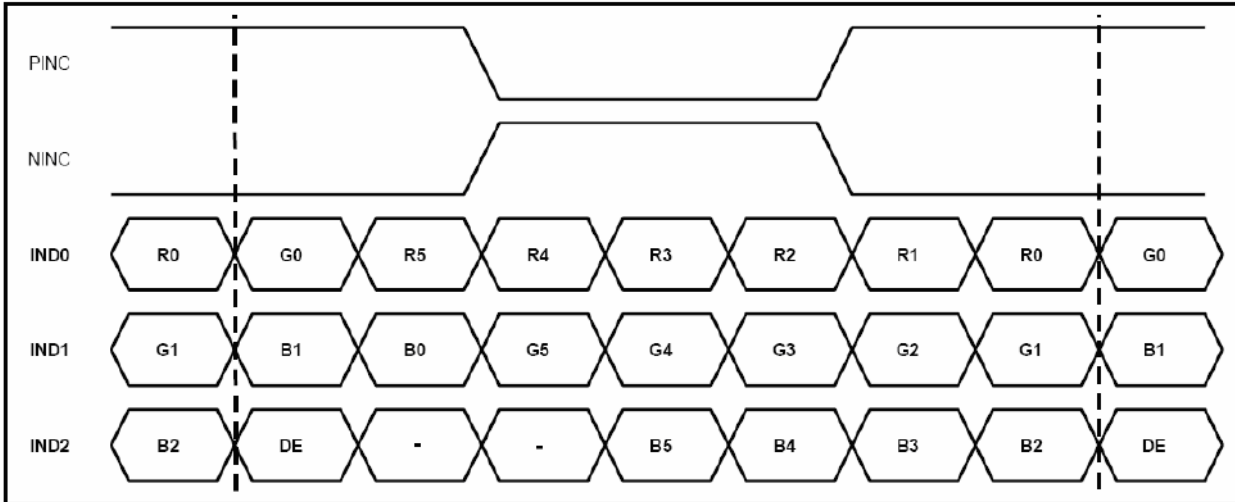

**8bit LVDS input**

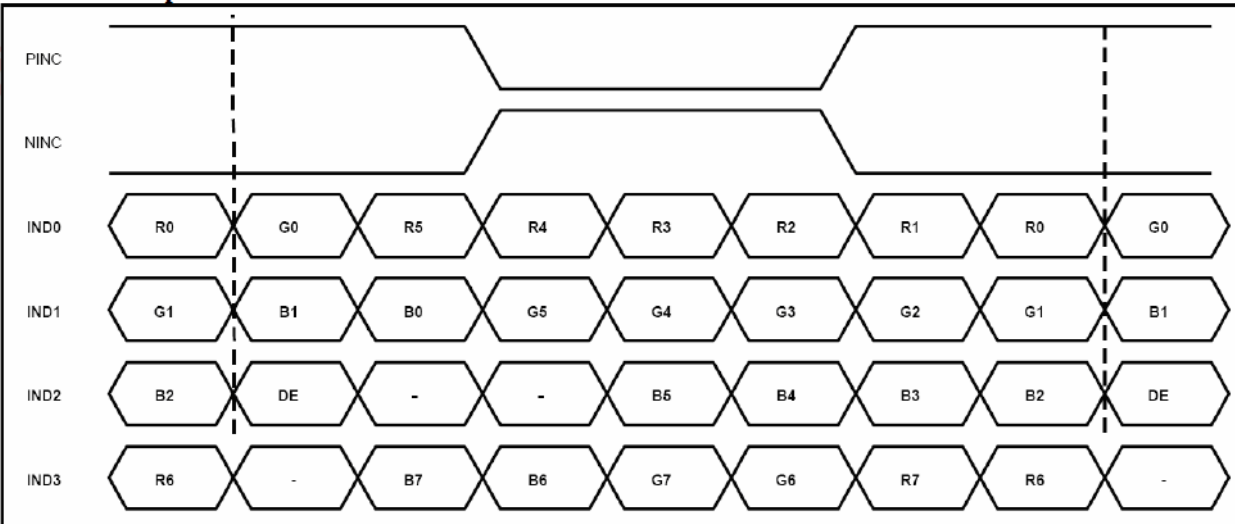

Note: Support DE timing mode only, SYNC mode not supported.



### 11.2 Power Sequence

#### a. Power on:

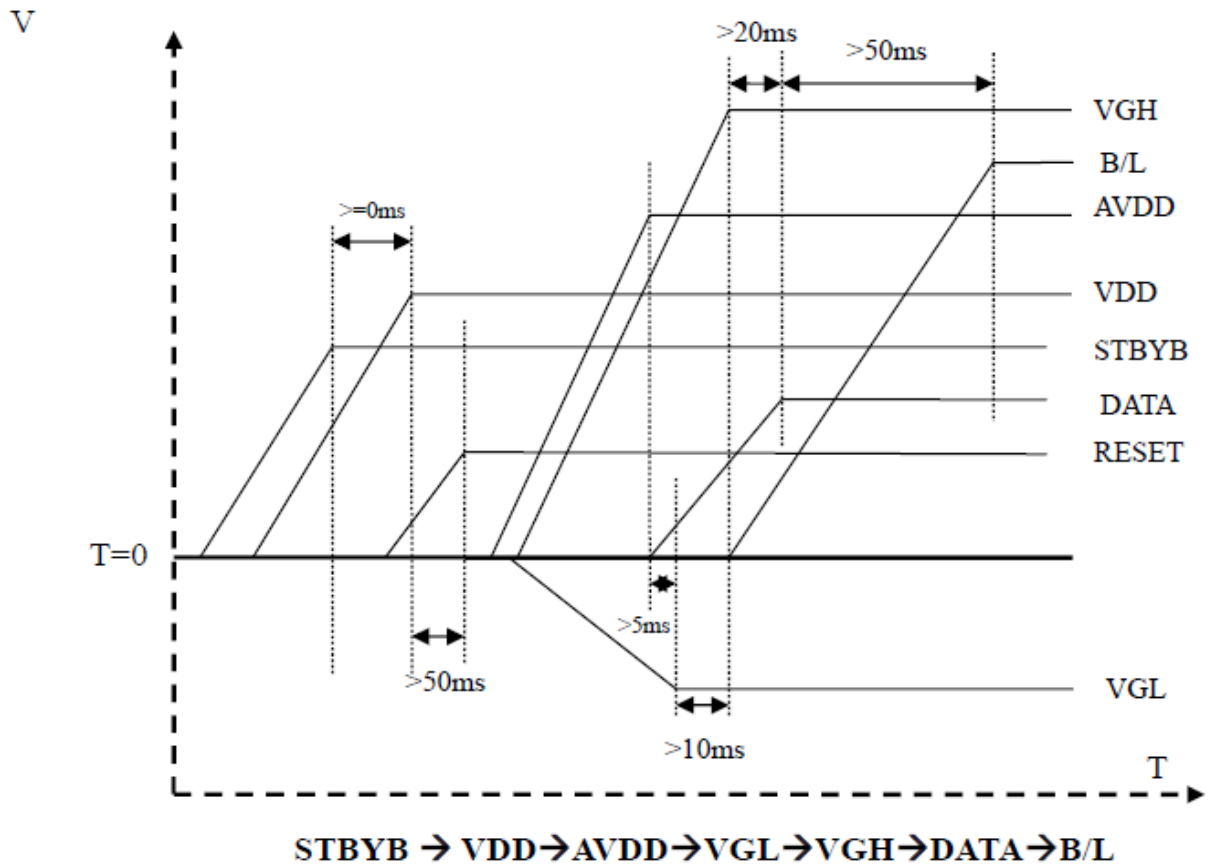

**b. Power off:**

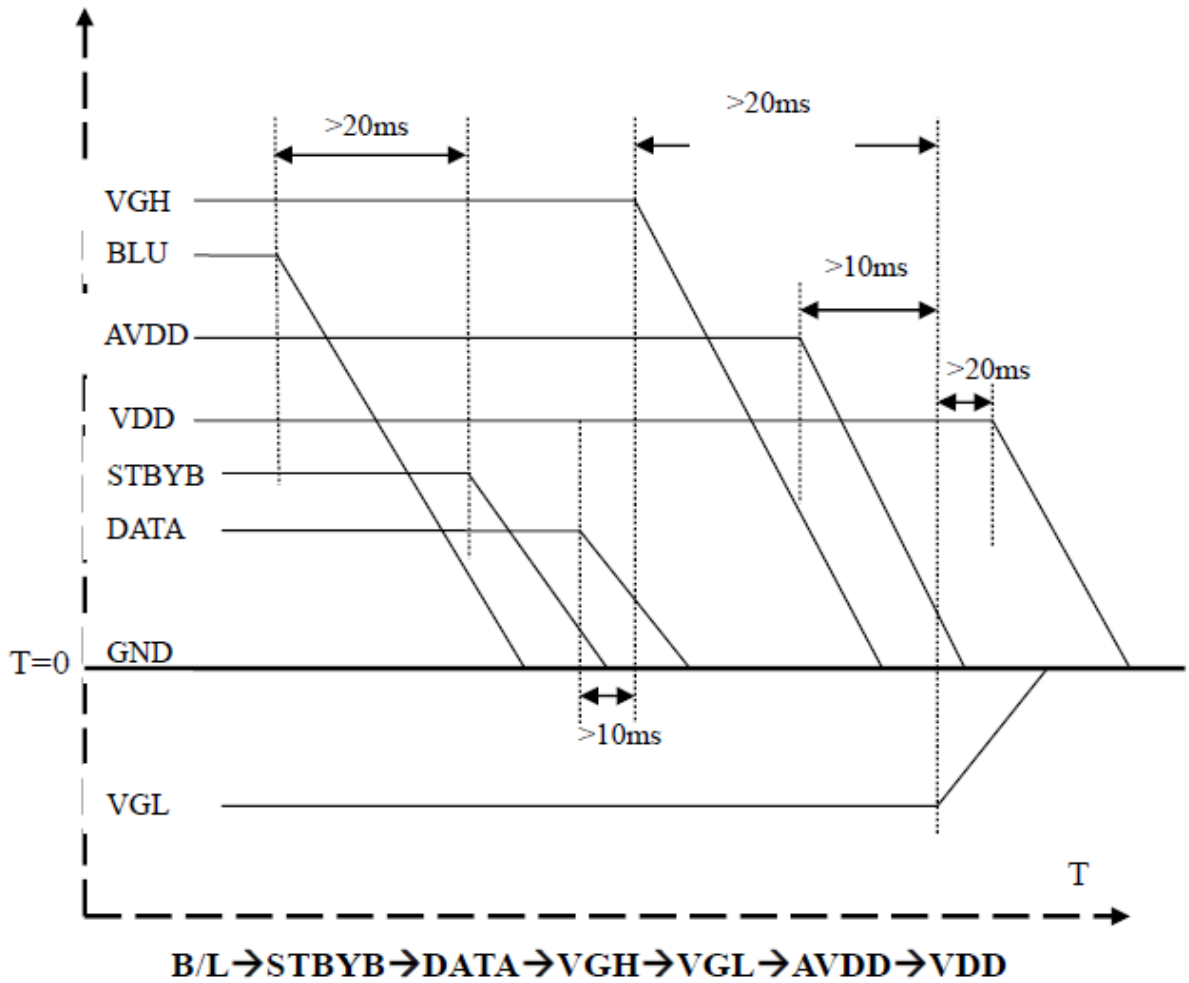

## 12. Optical Characteristics

The optical characteristics should be measured in a dark environment ( $\leq 1$  lux) or equivalent state with the methods shown in Note (4).

Item		Symbol	Conditions	Min.	Typ.	Max.	Unit	Note
Contrast Ratio		CR	$\theta_x=0^\circ, \theta_y=0^\circ$ Viewing Normal Angle	560	( 700 )	-	-	(2)
Response Time		$T_R$		-	4	8	ms	(3)
		$T_F$		-	12	24	ms	
Luminance(Center)		Y		450	( 500 )	-	cd/m <sup>2</sup>	(4)
Brightness uniformity		BUNI		-	( 70 )	-	%	(5)
Color Chromaticity	Red	Rx	0.576	0.626	0.676	-	(1),(4)	
		Ry	0.275	0.325	0.375	-		
	Green	Gx	0.278	0.328	0.378	-		
		Gy	0.498	0.548	0.598	-		
	Blue	Bx	0.086	0.136	0.186	-		
		By	0.091	0.141	0.191	-		
	White	Wx	0.260	0.310	0.360	-		
		Wy	0.280	0.330	0.380	-		
Viewing Angle	Horizontal	$\theta_{x+}$	$CR \geq 10$	60	( 70 )	-	deg.	(1),(4)
		$\theta_{x-}$		60	( 70 )	-		
	Vertical	$\theta_{y+}$		60	( 70 )	-		
		$\theta_{y-}$		50	( 60 )	-		

Note (1) Definition of Viewing Angle ( $\theta_x, \theta_y$ ):

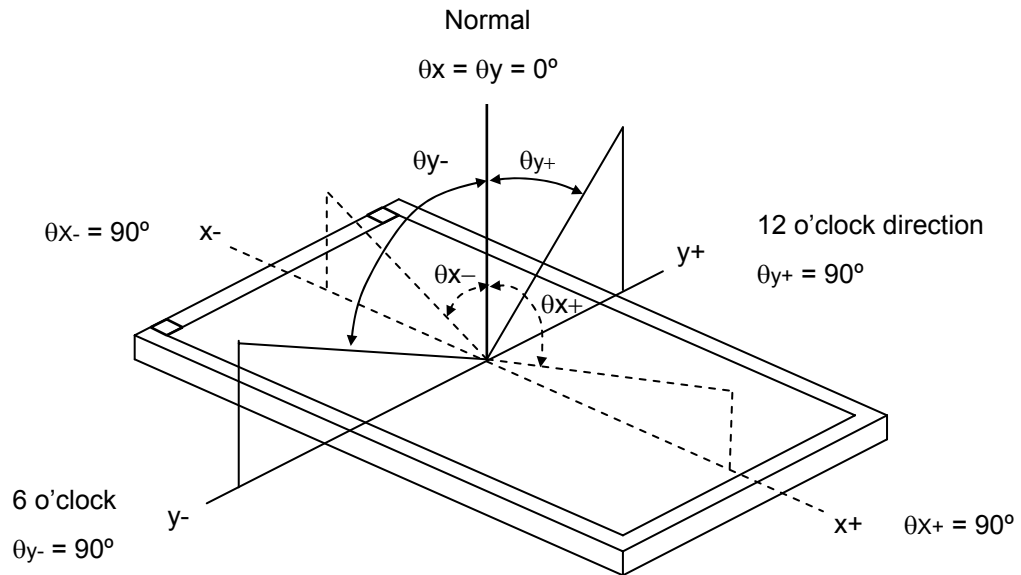

Note (2) Definition of Contrast Ratio (CR):

$$\text{Contrast ratio (CR)} = \frac{\text{Luminance measured when LCD on the "White" state}}{\text{Luminance measured when LCD on the "Black" state}}$$

Note (3) Definition of Response Time ( $T_R, T_F$ ):

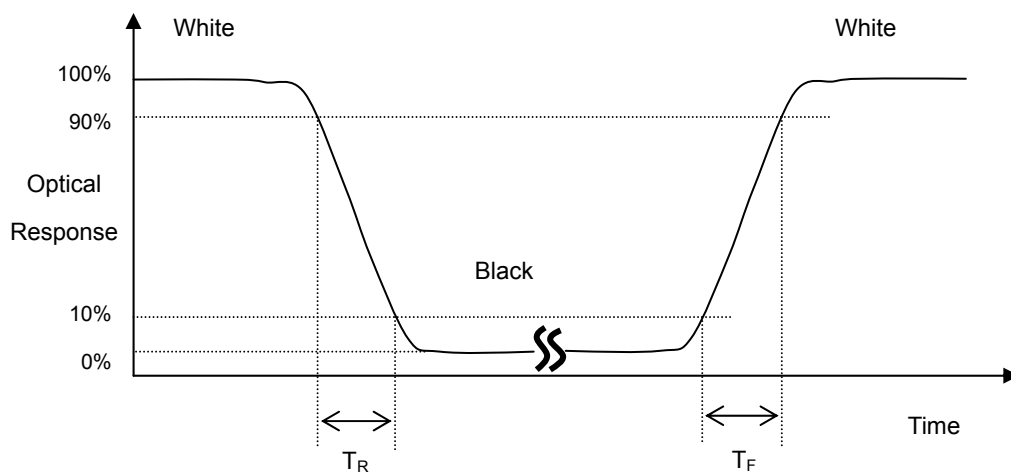

**Note (4) Measurement Set-Up:**

The LCD module should be stabilized at a given temperature for 30 minutes to avoid abrupt temperature change during measuring. In order to stabilize the luminance, the measurement should be executed after lighting Backlight for 30 minutes in a dark room or equivalent condition.

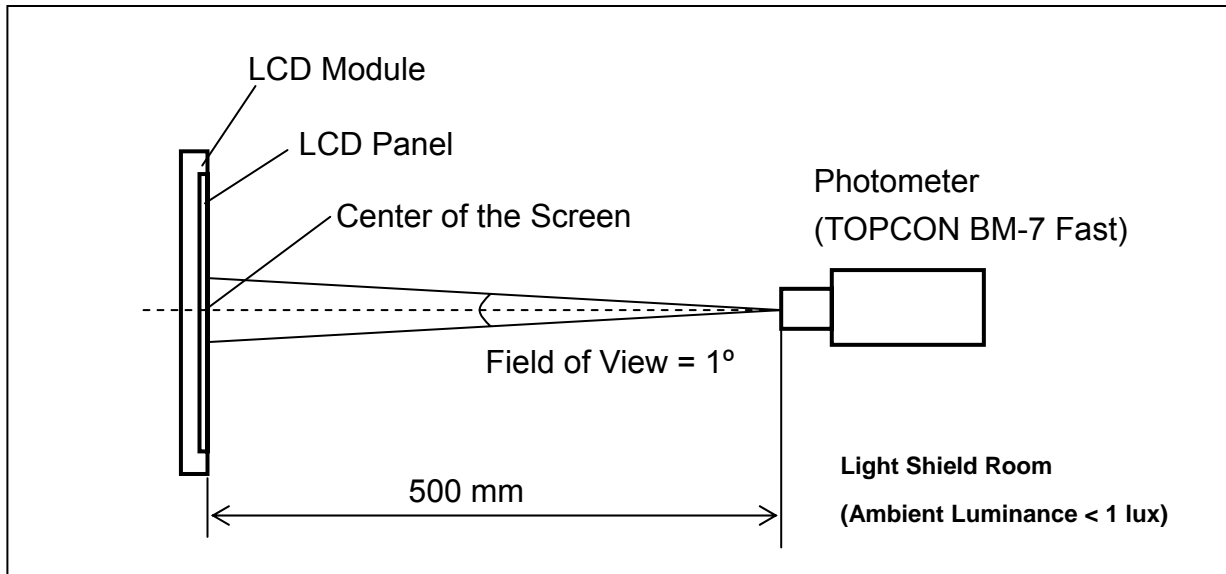

**Note (5) Definition of brightness uniformity**

$$\text{Brightness uniformity} = (\text{Min Luminance of 9 points}) / (\text{Max Luminance of 9 points}) \times 100\%$$

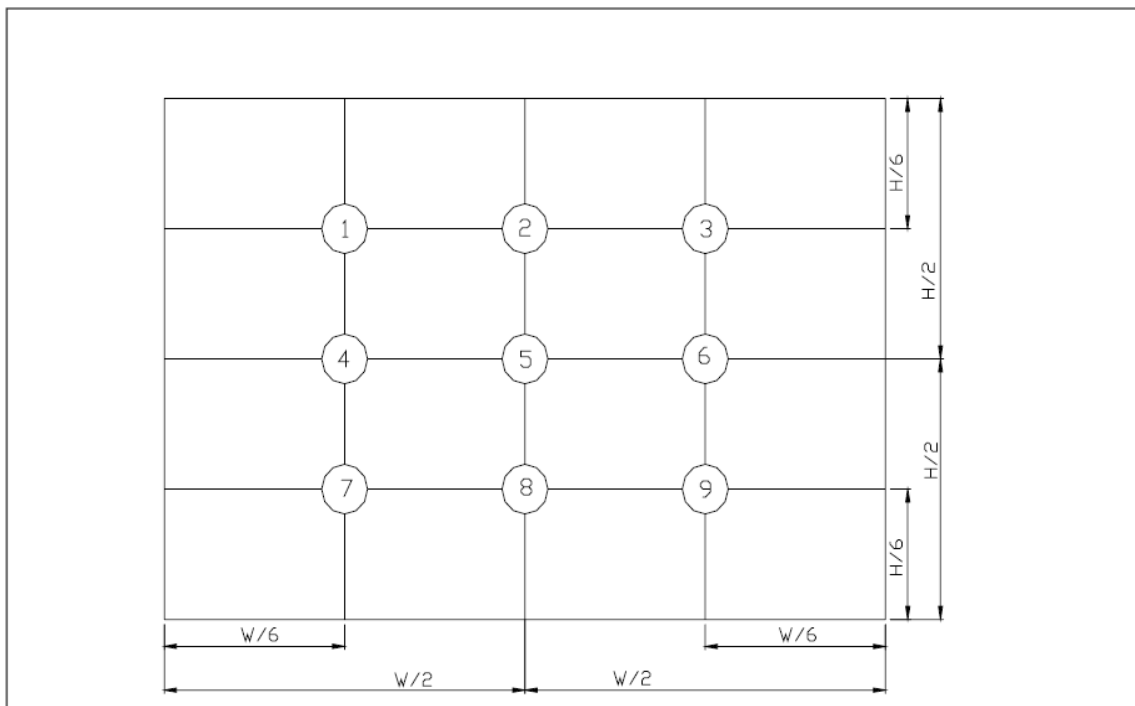

( 單位 : mm )

<b>EVERVISION</b>	<b>MODEL NO.</b>		<b>PAGE</b>
	VGG106004-6UFLWA	SPEC & SAMPLE	22

### 13. Reliability Test

Test Item	Test Conditions	Notes
High temperature Operation	70±3℃ ,T=240hrs	
Low temperature Operation	-20±3℃ ,T=240hrs	
High Temperature Storage	80±3℃ ,T=240hrs	1,2
Low Temperature Storage	-30±3℃ ,T=240hrs	1,2
Humidity Test	40℃ ,Humidity 90% ,240hrs	1,2
Thermal Shock Test	-30℃,30min~70℃,30min (200 cycle)	1,2
Vibration Test(Packing)	Sweep frequency 10~55~10HZ/min Amplitude:0.75mm Test direction:X,Y,Z/3 axis Duration 30min/each axis	2
Static Electricity	150Pf 330ohm ±8KV, 10time air discharge ±4KV, 10time connect discharge	

Note 1: Temperature is the ambient temperature of samples.

Note 2: Before cosmetic and function test, the product must have enough recovery time, at least 2 hours at room temperature.

**14. Packaging**

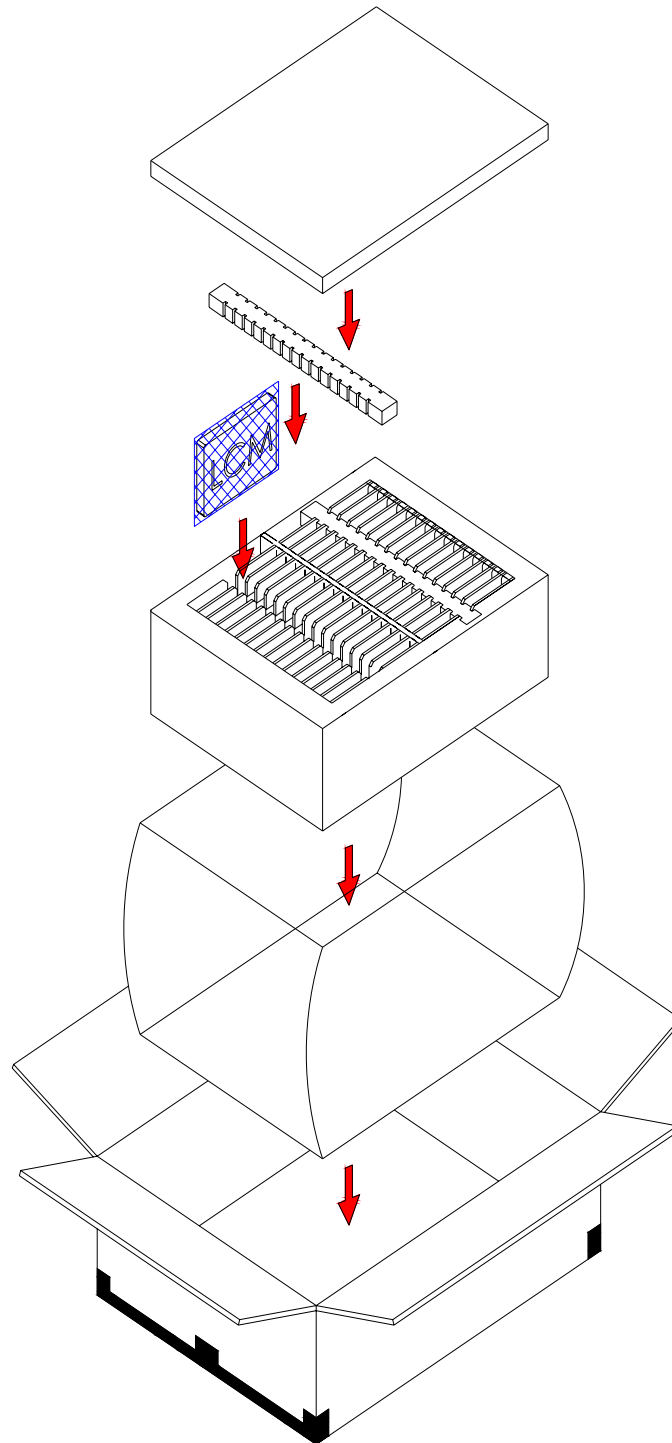

**PARTS LIST**

	ITEM	SIZE(LxWxH) unit : mm	MATERIAL	Q.T.Y	NOTE
1	PRODUCT	165.0x104.0x3.5		60	
2	EXTERNAL BOX	400.0x330.0x150.0	CARTON	1	

<b>EVERVISION</b>	<b>MODEL NO.</b>		<b>PAGE</b>
	VGG106004-6UFLWA	SPEC & SAMPLE	24

## **15. Precautions**

### **15.1 Assembly and Handling Precautions**

- (1) Do not apply rough force such as bending or twisting to the module during assembly.
- (2) It's recommended to assemble or to install a module into the user's system in clean working areas. The dust and oil may cause electrical short or worsen the polarizer.
- (3) Don't apply pressure or impulse to the module to prevent the damage of LCD panel and Backlight.
- (4) Always follow the correct power-on sequence when the LCD module is turned on. This can prevent the damage and latch-up of the CMOS LSI chips.
- (5) Do not plug in or pull out the I/F connector while the module is in operation.
- (6) Do not disassemble the module.
- (7) Use a soft dry cloth without chemicals for cleaning, because the surface of polarizer is very soft and easily scratched.
- (8) Moisture can easily penetrate into LCD module and may cause the damage during operation.
- (9) High temperature or humidity may deteriorate the performance of LCD module. Please store LCD module in the specified storage conditions.
- (10) When ambient temperature is lower than 10°C, the display quality might be reduced. For example, the response time will become slow.

### **15.2 Safety Precautions**

- (1) If the liquid crystal material leaks from the panel, it should be kept away from the eyes or mouth. In case of contact with hands, skin or clothes, it has to be washed away thoroughly with soap.
- (2) After the module's end of life, it is not harmful in case of normal operation and storage.

### **15.3 Terms of Warrant**

- (1) Acceptance inspection period  
The period is within one month after the arrival of contracted commodity at the buyer's factory site.
- (2) Applicable warrant period  
The period is within twelve months since the date of shipping out under normal using and storage conditions.



**16.Outline Drawing**

NOTE: UNSPECIFIED TOLERANCES IS  $\pm 0.3\text{mm}$

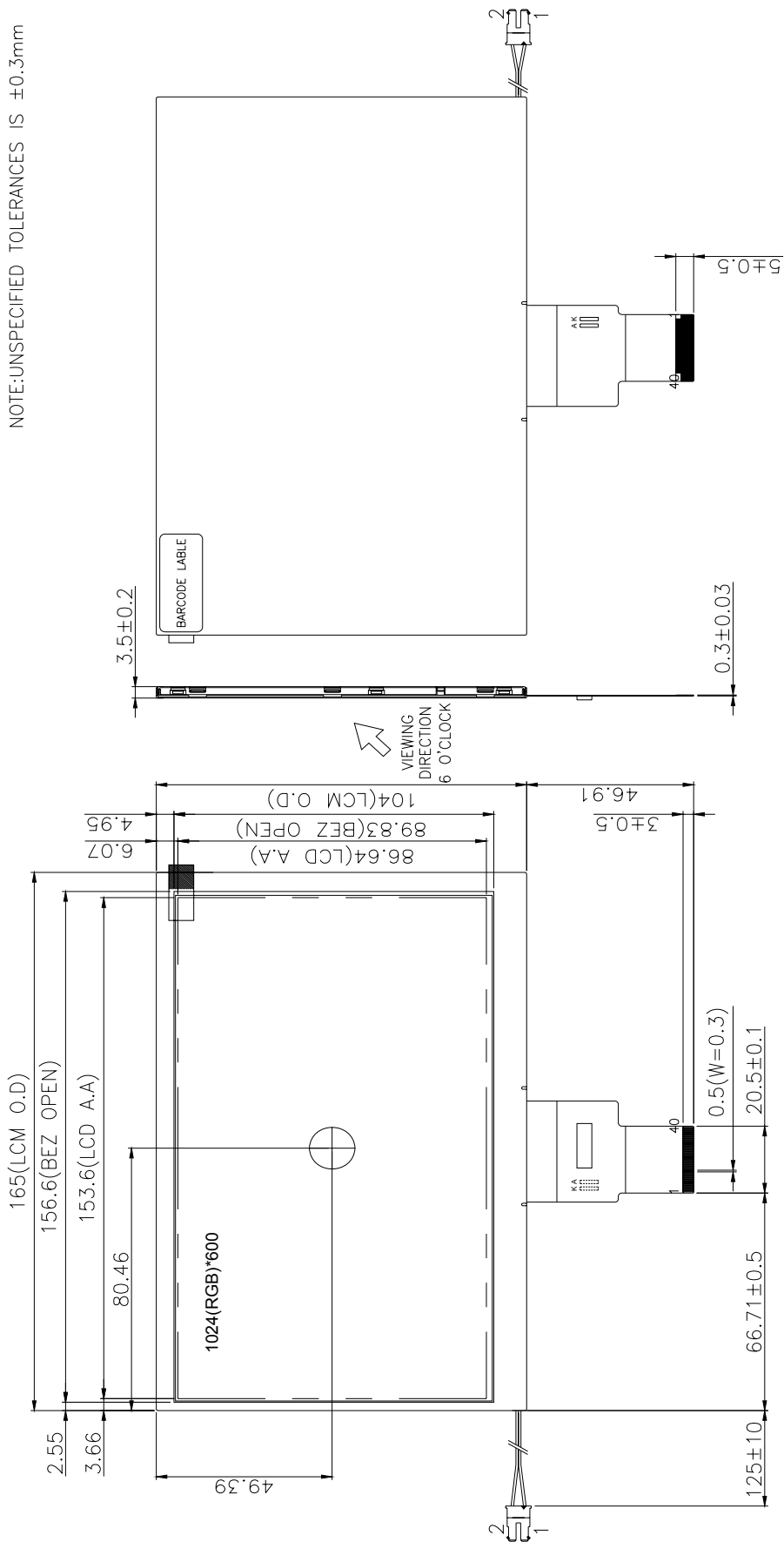

**17. Definition of Labels**

The bar code nameplate is pasted on each module as illustration, and its definitions are as following explanation.



(a) Module Name : VGG106004-6UFLWA

(b) Serial ID :

A B C D    E F G    H    IJKL

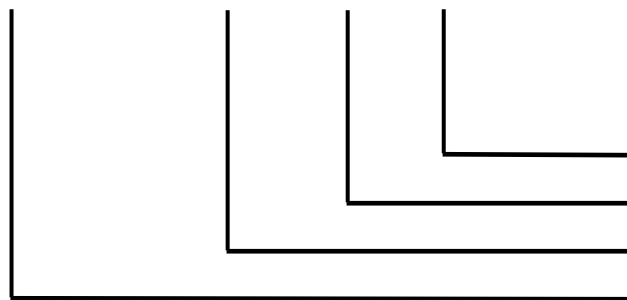

Serial No.  
Factory Code  
Manufactured Date  
Screen Size

Serial ID includes the information as below:

(a) Screen size (Diagonal): Inch Code (ABCD)

3.5" → 0350

10.4" → 1040

(b) Manufactured Date: Year, Month, Day (EFG)

Year (E)

Year	2000	2001	2002	2003	2004	2005	2006	2007	2008	2009
Mark	0	1	2	3	4	5	6	7	8	9
Year	2010	2011	2012	2013	2014	2015	2016	2017	2018	2019
Mark	A	B	C	D	E	F	G	H	I	J

<b>EVERVISION</b>	<b>MODEL NO.</b>		<b>PAGE</b>
	VGG106004-6UFLWA	SPEC & SAMPLE	27

Month (F)

Month	Jan.	Feb.	Mar.	Apr.	May	Jun.	Jul.	Aug.	Sep.	Oct.	Nov.	Dec.
Mark	1	2	3	4	5	6	7	8	9	A	B	C

Day (G)

Day	1	2	3	4	5	6	7	8	9	10	11	12	13	14	15	16
Mark	1	2	3	4	5	6	7	8	9	A	B	C	D	E	F	G
Day	17	18	19	20	21	22	23	24	25	26	27	28	29	30	31	
Mark	H	I	J	K	L	M	N	O	P	Q	R	S	T	U	V	

(c) Factory Code (H):

For EVERVISION internal use.

(d) Serial No. (IJKL):

Manufacturing sequence of product, for example: 0001~9999.

<b>EVERVISION</b>	<b>MODEL NO.</b>		<b>PAGE</b>
	VGG106004-6UFLWA	SPEC & SAMPLE	28

## **18. Incoming Inspection Standards**

### 1.0 Purpose:

This incoming inspection standards shall be apply to TFT-LCD Module

### 2.0: Visual inspection criteria

#### 2.1. Inspection condition is as followings

- Viewing distance is approximately 30cm
- Viewing angle is referred to the CAS
- Ambient temperature is in the room temperature
- Ambient illumination is 300+-50 LUX

<b>EVERVISION</b>	<b>MODEL NO.</b>		<b>PAGE</b>
	VGG106004-6UFLWA	SPEC & SAMPLE	29

Defect type		Criteria	
Electrical defect	Area (Note 2)	I	O
	Bright dots(Note 3)	N≤0	N≤2
	Dark dots (Note 4)	N≤2	N≤4
	Bright dot-2Adjacent(note5)	N≤0	
	Dark dot-2Adjacent(note6)	N≤0	
	Dark or bright dots-3 and more adjacent(note6)	N≤0	
	Total bright and dark dots	N≤4	
	Minimum distance between bright dots	5mm	
	Minimum distance between dark dots	5mm	
	Minimum distance between bright and bright dots	5mm	
Visual defect	Foreign material	Circular foreign material: dark/bright sport	Visible under:ND5% 1:D≤0.15mm:No count 2:0.15mm<D≤0.5mm,N≤4 3:D>0.5mm:Not allowable
		Linear foreign material: bright or dark line	Invisible under ND5% 0.1mm<W≤0.5mm, 0.3mm<L≤1.5mm,N≤4 Visible under ND5% 0.05mm≤w≤0.1mm, 0.3mm≤L≤0.7mm,N≤4
	Polarizer	Linear scratch	1:BM:No Count 2:Pixel area 0.05mm≤w≤0.2mm, 1.0mm≤L≤5.0mm,N≤4
		Bubble peeling	1:BM:No Count 2:Pixel area 0.15mm≤D<0.5mm,N≤4
	Mura & leak	ND5%	

D: diameter, N: number, W: horizontal width, L: vertical height

<b>EVERVISION</b>	<b>MODEL NO.</b>		<b>PAGE</b>
	VGG106004-6UFLWA	SPEC & SAMPLE	30

2.2: others

Note(1)

- a. every dot herein means sub-pixel(each red ,green ,blue color)
- b. damaged less than half size of sub-pixel is not counted as defect
- c. extraneous substances which can be wiped out are not considered as defect
- d. defects which is on the black(outside of active area) ore not considered as defect.

Note (2) definition of area.

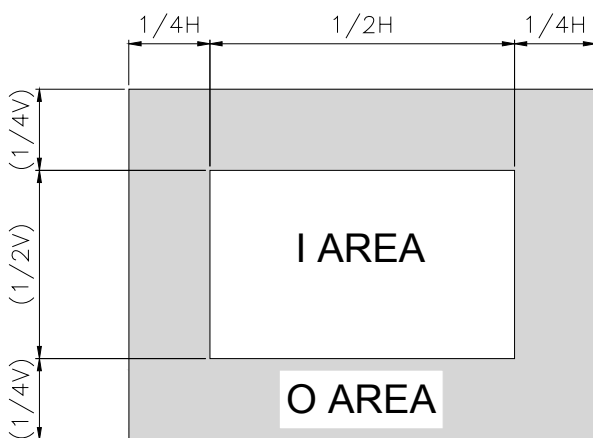

Note(3) Bright dot defect definition

Bright area is more than 50% of one dot. All bright dot defect must be visible through 5% ND filter

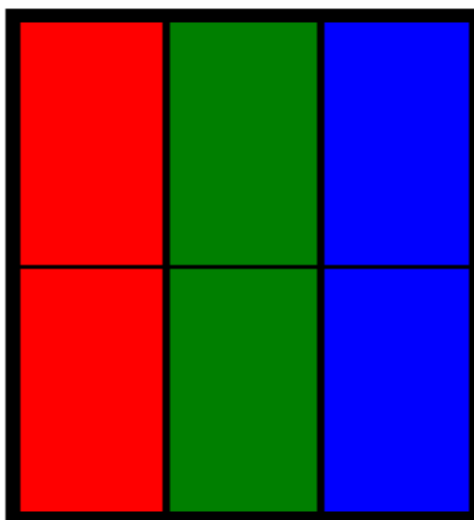

A diagram of a pixel.

One dot refers to one upper and one lower R, G, or B combined. (The middle BM, or black mask, is thinner, while the top and bottom BM are thicker.)

Note(4) Dark dot defect definition

-dark area is more than 50% of one dot. All bright dot defect must be visible through 5% ND filter



Note (5) bright dot defect description

-two adjacent

Type 1



Note (6) Dark dot defect description

-two adjacent

Type1



<b>EVERVISION</b>	<b>MODEL NO.</b>		<b>PAGE</b>
	VGG106004-6UFLWA	SPEC & SAMPLE	32

Note(7) dark dot defect description

-three adjacent

Type1



Type2



type3



type4



Note(8) minimum distance between dot defects

Bright dot to bright dot

The pitch is less than 5mm.

Dark dot to dark dot

The pitch is less than 5mm.

Bright dot to dark dot

The pitch is less than 5mm.

Note(9) "Average diameter" description

Average diameter=(a+b)/2

The defect that are not defined above and considered to be problem shall be reviewed and discussed by both parties

Note(10) Bright dot, mura and leak are defined through transmission ND Filter as following.

Form the eyes to the TFT LCM surface is 30cm.

## 18.2 Handling of LCM

- (1) Don't give external shock.
- (2) Don't apply excessive force on the surface.
- (3) Liquid in LCD is hazardous substance. Must not lick and swallow. when the liquid is attach to your hand, skin, cloth etc. Wash it out thoroughly and immediately.
- (4) Don't operate it above the absolute maximum rating.
- (5) Don't disassemble the LCM.