

億力光電股份有限公司

EVERVISION ELECTRONICS CO., LTD.

Product Specification For LCD Module

(KVPF-7B-002-16)

Model NO. : VGG804818-6UFLWC(RoHS)

REVISION : 3

APPROVAL FOR SPECIFICATIONS ONLY

APPROVAL FOR SPECIFICATIONS AND SAMPLE

CUSTOMER :

STD

APPROVED BY :

EVERVISION LCM R&D CENTER

APPROVED BY

CHECKED BY

PREPARED BY

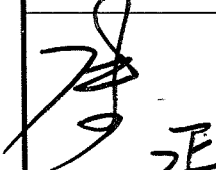
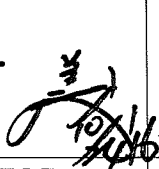
正

DIRECTOR

張乃元
10/24/16

MANAGER

余宗利
10/24/16

Mechanism Engineer

詹俊訓
10/24/16

Electronic Engineer

億力光電股份有限公司總公司
EVERVISION ELECTRONICS CO., LTD.
台北市中和區建一路 186 號 6 樓之 5
6F.-5, No.186, Jian 1st Rd., Zhonghe Dist.,
New Taipei City 235, Taiwan (R.O.C.)
TEL : +886 2 8227-2788
FAX : +886 2 8227-2799

億力光電股份有限公司台中分公司
EVERVISION ELECTRONICS CO., LTD.
-Taichung Branch
台中市潭子區建國路 19 號
No.19, Jianguo Rd., Tanzi Dist.,
Taichung City 427, Taiwan (R.O.C.)
TEL : +886 4 2532-8889
FAX : +886 4 2532-6689

勁佳光電(昆山)有限公司
VBEST ELECTRONICS(KUNSHAN) Co., Ltd.
江蘇省昆山市玉山鎮高科技工業園城北路 8 號
No.8, Chengbei Rd., Hi-Tech Industry Park,
Yushan Town, Kunshan City, Jiangsu, China.
TEL : +86 512 5778 7288
FAX : +86 512 5777 0688

勁佳光電(昆山)有限公司東莞分公司
VBEST ELECTRONICS(KUNSHAN) Co., Ltd.
- DongGuan Branch
東莞市莞城區東縱大道天寶路 23 號
No.23 Tian Bao Rd., Dong Zong St.,
Dong Guan City, Guang Dong, China.
TEL : +86 769 3887 5000
FAX : +86 769 3896 0580

<http://www.evervisionlcd.com>

EVERVISION	MODEL NO.		PAGE
	VGG804818-6UFLWC	SPEC SAMPLE	2

1. Table of Contents

No.	Contents	Page
1	Table of Contents	2
2	Record of Revisions	3
3	Module Numbering System	4
4	Application	5
5	Features	5
6	General Specifications	5
7	Absolute Maximum Ratings	6
8	Electrical Characteristics	7
9	Block Diagram	9
10	Input / Output Terminals Pin Assignment	10
11	Interface Timing	15
12	Optical Characteristics	26
13	Reliability Test	29
14	Packaging	30
15	Precautions	31
16	Outline Drawing	34
17	Definition of Labels	35
18	Incoming Inspection Standards	37

EVERVISION	MODEL NO.		PAGE
	VGG804818-6UFLWC	SPEC SAMPLE	4

3. Module Numbering System

V G G 8048 18 – 6 U F L W C

Serial No.: A~Z

Backlight Color:

N: Without Backlight;
A: Amber; **B:** Blue; **G:** Green;
L: Yellow; **O:** Orange; **R:** Red;
W: White; **Y:** YellowGreen;
X: Others

Backlight Type:

N: Without Backlight; **E:** EL; **F:** CCFL;
L: General LED; **H:** High NTSC LED ;
R: RGB LED; **X:** Others

LCD Model:

A: ASTN; **B:** STN Blue; **C:** CSTN; **D:** DSTN;
F: TFT; **G:** STN Gray; **H:** HTN; **I:** IBN;
K: Black Mask TN **L:** LTPS; **M:** MVA;
N: others; **O:** OLED; **P:** PLED; **S:** IPS;
T: TN; **U:** FSC TN; **W:** FSTN Black/white;
X: FFSTN; **Y:** STN Yellow;

LCD Type:

R: Reflective/Positive;
S : Reflective/Negative ;
F : Transflective/Positive ;
G: Transflective/Negative ;
U: Transmissive/Positive ;
T: Transmissive/Negative ; **N:** Others

Temperature Range & View Direction:

General Purpose : **1:**6H **2:**12H **3:**3H **4:**9H **5:**Others
High Performance: **6:**6H **7:**12H **8:**3H **9:**9H **0:**Others

STD Product Serial No.: 01~99

Customer Made Serial No.: A1,A2...A9,B1,B2...B9,C1..

Display Function:

Segment Number / Characters Lines / Column and Row Dots
/ Length * Width of Other

Display Type:

C: Character Type; **G:** Graphic Type; **S:** Segment Type; **O:** Other

Package Type:

B: COB; **F:** COF; **G:** COG; **H:** Heat Seal; **S:** SMT; **T:** TAB; **O:** Others

EVERVISION	MODEL NO.		PAGE
	VGG804818-6UFLWC	SPEC SAMPLE	5

4. Application

This specification is applied to the 7 inch WVGA supported TFT-LCD module, and can display true 16.7M colors(8 bit/ color). The module is designed for OA, Car TV application and other electronic products which require flat panel display of digital signal interface. This module is composed of a 7" TFT-LCD panel, a driver circuit and LED backlight unit and used as the input devices for general electric appliances via both finger and Capacitive stylus pen.

5. Features

- WVGA (800×480 pixels) resolution.
- Digital 24 bit parallel RGB.
- Dot inversion mode with stripe type.
- Projected Capacitive Touch
 - I²C Interface
 - Multi Touch (Ten points)

6. General Specifications

Item	Specifications	Unit
Screen Size	7 (Diagonal)	inch
Display Format	800RGB(H)×480(V)	dot
Active Area	154.08(H)×85.92(V)	mm
Dot Pitch	0.0642(H)×0.1790(V)	mm
Pixel Configuration	RGB Vertical Stripe	-
Display Mode	TN Type Transmissive Mode Normally White	-
Surface Treatment	Clear(7H)	-
Viewing Direction	6 O'clock (The Gray Inversion will appear at this direction)	-
Outline Dimension	164.9(W)×100.0(H)×7.25(D)	mm
Weight	212	g
RoHS Compliance	Evervision certifies this product to be in compliance with European Union Directive 2011/65/EU on the restriction of certain hazardous substances in electrical and electronic equipment.	-

7. Absolute Maximum Ratings

7.1 Absolute Ratings of Environment

Item	Symbol	Value		Unit	Note
		Min.	Max.		
Storage Temperature	T _{ST}	-30	+80	°C	(1)(2)
Operating Ambient Temperature	T _{OP}	-20	+70	°C	(1)(2)

Note1: Background color changes slightly depending on ambient temperature.

This phenomenon is reversible.

Note2: Please refer to item of RELIABILITY.

7.2 Electrical Absolute Ratings

7.2.1 TFT-LCD Module

(Ta=25±2°C, GND=V_{SS}=0V, Note 1)

Item	Symbol	Value		Unit	Note
		Min.	Max.		
Digital Power Supply Voltage	DV _{DD}	-0.3	5.0	V	-
Analog Power Supply Voltage	AV _{DD}	6.5	13.5	V	-
Gate High Voltage	V _{GH}	-0.3	40.0	V	-
Gate Low Voltage	V _{GL}	-20.0	0.3	V	-
Gate High To Gate Low Voltage	V _{GH} - V _{GL}	-	40.0	V	-

7.2.2 Backlight Absolute Maximum Ratings

(Ta=25±2°C, Note 1)

Item	Symbol	Value		Unit	Note
		Min.	Max.		
LED Reverse Voltage	VR	-	1.2	V	Each LED (2)
LED Forward Current	IF	-	25	mA	Each LED

Note 1: The absolute maximum rating values of this product are not allowed to be exceeded at any times. A module should be used with any of the absolute maximum ratings exceeded, the characteristics of the module may not be recovered, or in an extreme condition, the module may be permanently destroyed.

Note 2: VR Conditions: Zener Diode 20mA

8. Electrical Characteristics

8.1 TFT-LCD Module

(Ta=25±2°C)

Item	Symbol	Value			Unit	Note
		Min.	Typ.	Max.		
Digital Power Supply Voltage	DV _{DD}	3.0	3.3	3.6	V	-
Analog Power Supply Voltage	AV _{DD}	10.2	10.4	10.6	V	-
Gate High Voltage	V _{GH}	15.3	16.0	16.7	V	-
Gate Low Voltage	V _{GL}	-7.7	-7.0	-6.3	V	-
Input signal voltage	V _{COM}	3.6	3.8	4.0	V	-
Digital Power Supply Current	DI _{DD}	-	4.0	10	mA	(1)
Analog Power Supply Current	AI _{DD}		20	50	mA	(1)
Gate High Current	I _{GH}		0.2	1	mA	(1)
Gate Low Current	I _{GL}		0.2	1	mA	(1)
Input High Threshold Voltage	V _{IH}	0.7 DV _{DD}	-	DV _{DD}	V	-
Input Low Threshold Voltage	V _{IL}	0	-	0.3 DV _{DD}	V	-
VSYNC Frequency	F _V	-	60	-	Hz	-
DCLK Frequency	DCLK	-	33.26	-	MHz	-

Note (1) The specified power consumption is under the conditions at DV_{DD} =3.3V, AV_{DD} =10.4V, V_{GH} =16.0V, V_{GL} =-7V, V_{COM} =3.8V ,F_V=60Hz, whereas a power dissipation check pattern below is displayed.

Black Pattern / 0 Gray

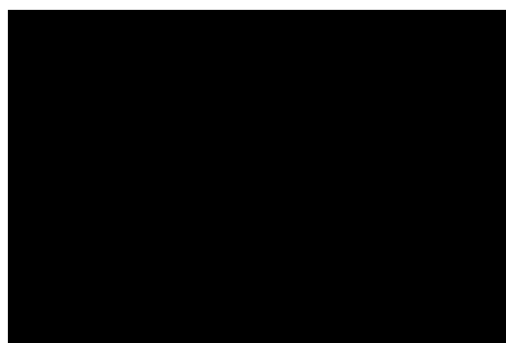

Active Area

EVERVISION	MODEL NO.		PAGE
	VGG804818-6UFLWC	SPEC SAMPLE	8

8.2 Backlight Unit

(Ta=25±2°C)

Item	Symbol	Value			Unit	Note
		Min.	Typ.	Max.		
Current of Backlight Unit	I _B	170	180	200	mA	-
Voltage of Backlight Unit	V _B	8.4	9.3	10.2	V	(1)
Power Consumption	P _{BL}	-	(1.674)	-	W	-
LED Life Time(25°C)	-	20000	-	-	hr	(2)

Note 1: The LED Supply Voltage is defined by the number of LED at Ta=25°C and IL =180mA.

Note 2: The “LED life time” is defined as the module brightness decrease to 50% original brightness at Ta=25°C and IL =180mA. The LED lifetime could be decreased if operating IL is larger than 180 mA.

8.3 Projected Capacitive Touch

Item	Symbol	Value			Unit	Note
		Min.	Typ.	Max.		
Operating Voltage	VDD	3.0	3.3	3.6	V	-
Power Supply Current	IDD	-	20.5	28.7	mA	(1)
Input High Threshold Voltage	V _{IH}	0.7VDD	-	VDD	V	-
Input Low Threshold Voltage	V _{IL}	-0.3	-	0.3VDD	V	-
Output High Threshold Voltage	V _{OH}	0.7VDD	-	-	V	-
Output Low Threshold Voltage	V _{OL}	-	-	0.3VDD	V	-
Power Consumption	P _L	-	67.65	94.71	mW	@3.3V
Report Rate	R _R	-	60	-	Hz	-
Interface	I ² C					-
Function	Multi Touch					-

Note (1) This test condition is touched with 10 points.

9. Block Diagram

9.1 TFT-LCD Module with Backlight Unit

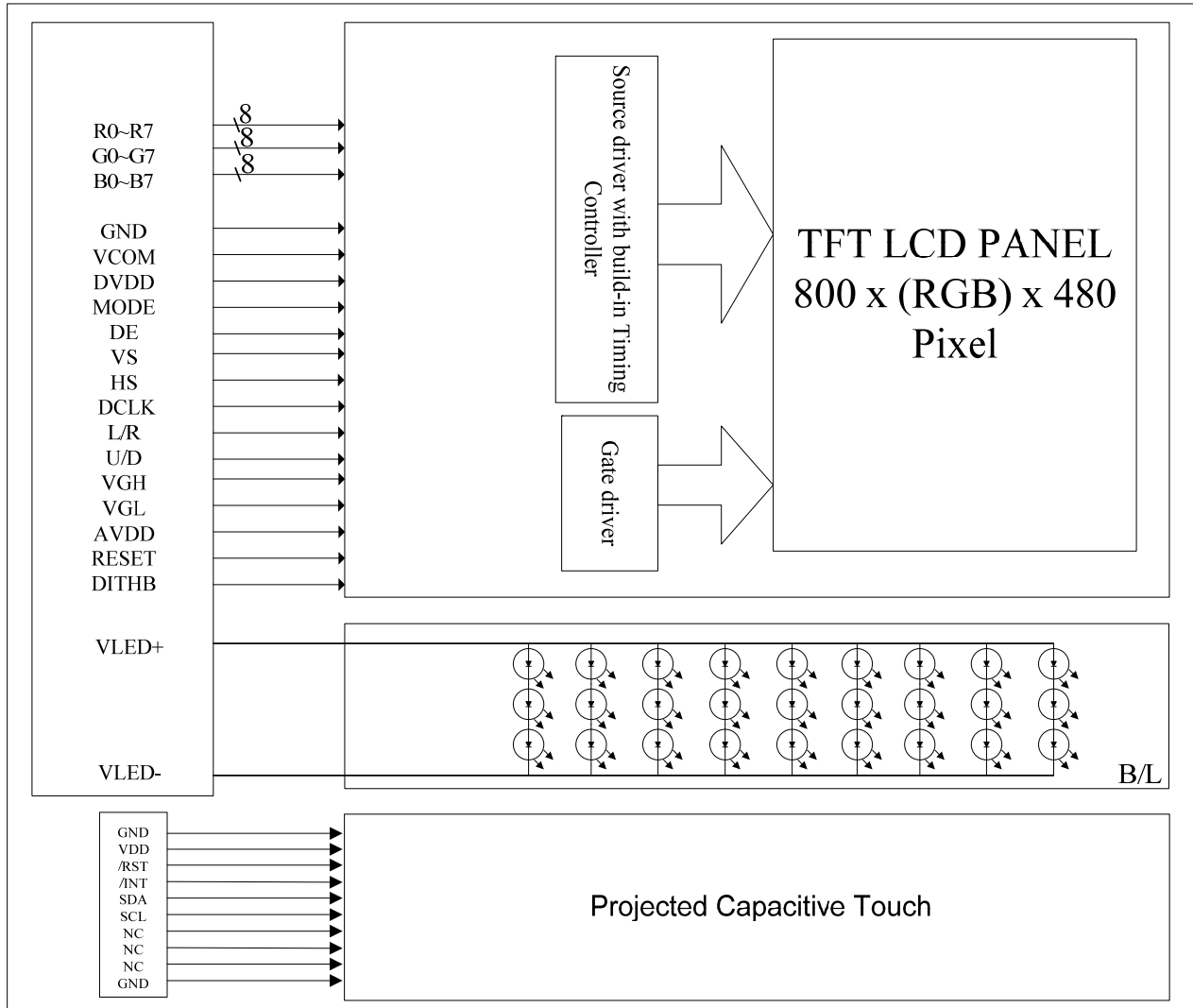

10. Input / Output Terminals Pin Assignment

10.1 TFT-LCD Module

Connector: Hirose FH12A-50S-0.5SH

Pin No.	Symbol	I/O	Description	Remark
1	VLED+	P	Power for LED backlight(Anode)	
2	VLED+	P	Power for LED backlight(Anode)	
3	VLED-	P	Ground for LED backlight(Cathode)	
4	VLED-	P	Ground for LED backlight(Cathode)	
5	GND	P	Ground	
6	V _{COM}	I	Common voltage	
7	DV _{DD}	P	Power for Digital Circuit	
8	MODE	I	DE/SYNC mode select	Note 1
9	DE	I	Data Input Enable	
10	VS	I	Vertical Sync Input	
11	HS	I	Horizontal Sync Input	
12	B7	I	Blue data(MSB)	
13	B6	I	Blue data	
14	B5	I	Blue data	
15	B4	I	Blue data	
16	B3	I	Blue data	
17	B4	I	Blue data	
18	B1	I	Blue data	Note 2
19	B0	I	Blue data(LSB)	Note 2
20	G7	I	GREEN data(MSB)	
21	G6	I	GREEN data	
22	G5	I	GREEN data	
23	G4	I	GREEN data	
24	G3	I	GREEN data	
25	G2	I	GREEN data	
26	G1	I	GREEN data	Note 2
27	G0	I	GREEN data(LSB)	Note 2
28	R7	I	RED data(MSB)	
29	R6	I	RED data	
30	R5	I	RED data	

Pin No.	Symbol	I/O	Description	Remark
31	R4	I	RED data	
32	R3	I	RED data	
33	R2	I	RED data	
34	R1	I	RED data	Note 2
35	R0	I	RED data (LSB)	Note 2
36	GND	P	Ground	
37	DCLK	I	Sample clock	Note 3
38	GND	P	Ground	
39	L/R	I	Left / right selection	Note 4,5
40	U/D	I	Up / down selection	Note 4,5
41	V _{GH}	P	Gate ON Voltage	
42	V _{GL}	P	Gate OFF Voltage	
43	AV _{DD}	P	Power for Analog Circuit	
44	RESET	I	Global reset pin.	Note 6
45	NC	-	No connection	
46	V _{COM}	I	Common Voltage	
47	DITHB	I	Dithering function	Note 7
48	GND	P	Ground	
49	NC	-	No connection	
50	NC	-	No connection	

I: input, O: output, P: Power

Note 1: DE/SYNC mode select. Normally pull high.

When select DE mode, MODE="1", VS and HS must pull high.

When select SYNC mode, MODE="0", DE must be grounded.

Note 2: When input 18 bits RGB data, the two low bits of R, G and B data must be grounded.

Note 3: Data shall be latched at the falling edge of DCLK.

Note 4: Selection of scanning mode

Setting of scan control input		Scanning direction
U/D	L/R	
GND	DV _{DD}	Up to down, left to right
DV _{DD}	GND	Down to up, right to left
GND	GND	Up to down, right to left
DV _{DD}	DV _{DD}	Down to up, left to right

Note 5: Definition of scanning direction.

Refer to the figure as below:

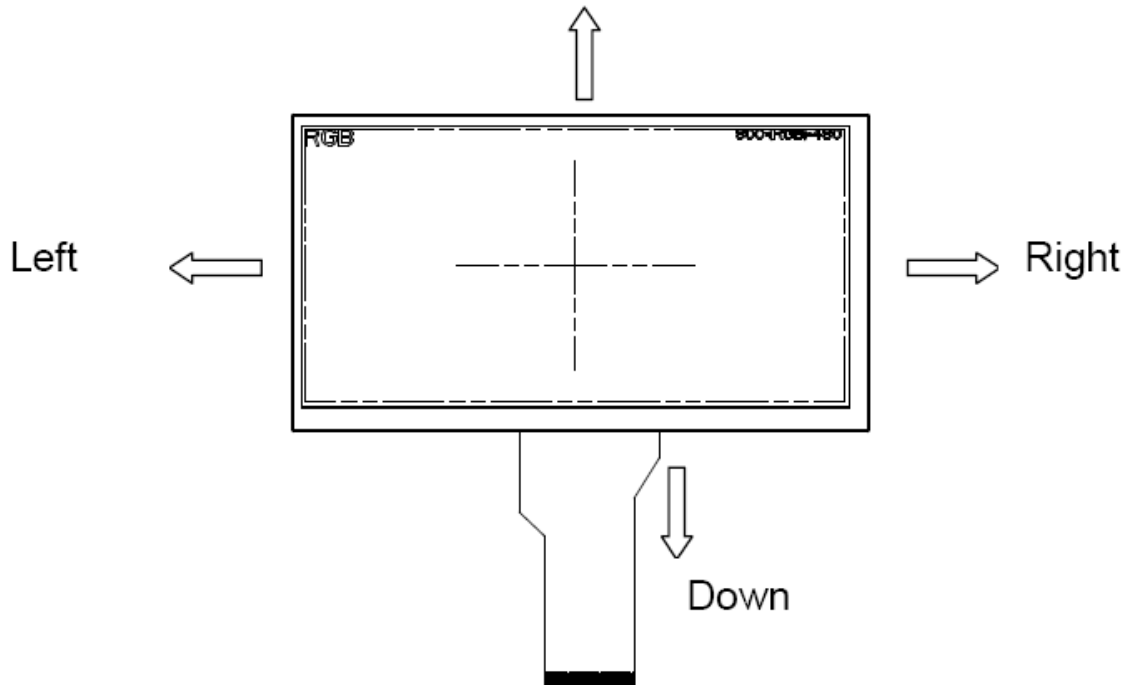

Note 6: Global reset pin. Active low to enter reset state. Suggest to connect with an RC reset circuit for stability. Normally pull high.

Note 7: Dithering function enable control, normally pull high.

When DITHB="1", Disable internal dithering function,

When DITHB="0", Enable internal dithering function,

10.2 Improved Projected Capacitive Touch

Connector: CVILUX CF25101D0R0-05

Pin No.	Symbol	I/O	Description
1	GND	I	System ground.
2	VDD	I	+3.3V power supply.
3	/RST	I	External reset signal, active low.
4	/INT	O	Interrupt signal, active low, asserted to request Host start a new transaction.
5	SDA	I/O	I ² C data signal.
6	SCL	I	I ² C clock signal.
7	NC	-	Not Connection
8	NC	-	Not Connection
9	NC	-	Not Connection
10	GND	I	System ground.

10.3 Color Data Input Assignment

The brightness of each primary color(red, green and blue) is based on the 8 bit gray scale data input for the color. The higher the binary input, the brighter the color. The table provides the assignment of color versus data input.

Color		Data Signal																							
		Red								Green								Blue							
		R7	R6	R5	R4	R3	R2	R1	R0	G7	G6	G5	G4	G3	G2	G1	G0	B7	B6	B5	B4	B3	B2	B1	B0
Basic Colors	Black	0	0	0	0	0	0	0	0	0	0	0	0	0	0	0	0	0	0	0	0	0	0	0	
	Red	1	1	1	1	1	1	1	1	0	0	0	0	0	0	0	0	0	0	0	0	0	0	0	
	Green	0	0	0	0	0	0	0	0	1	1	1	1	1	1	1	0	0	0	0	0	0	0	0	
	Blue	0	0	0	0	0	0	0	0	0	0	0	0	0	0	0	1	1	1	1	1	1	1	1	
	Cyan	0	0	0	0	0	0	0	0	1	1	1	1	1	1	1	1	1	1	1	1	1	1	1	
	Magenta	1	1	1	1	1	1	1	1	0	0	0	0	0	0	0	1	1	1	1	1	1	1	1	
	Yellow	1	1	1	1	1	1	1	1	1	1	1	1	1	1	1	0	0	0	0	0	0	0	0	
	White	1	1	1	1	1	1	1	1	1	1	1	1	1	1	1	1	1	1	1	1	1	1	1	
Gray Scale Of RED	Red(0) / Dark	0	0	0	0	0	0	0	0	0	0	0	0	0	0	0	0	0	0	0	0	0	0		
	Red(1)	0	0	0	0	0	0	1	0	0	0	0	0	0	0	0	0	0	0	0	0	0	0		
	Red(2)	0	0	0	0	0	0	1	0	0	0	0	0	0	0	0	0	0	0	0	0	0	0		
	:	:	:	:	:	:	:	:	:	:	:	:	:	:	:	:	:	:	:	:	:	:	:		
	:	:	:	:	:	:	:	:	:	:	:	:	:	:	:	:	:	:	:	:	:	:	:		
	Red(253)	1	1	1	1	1	1	0	1	0	0	0	0	0	0	0	0	0	0	0	0	0	0		
	Red(254)	1	1	1	1	1	1	1	0	0	0	0	0	0	0	0	0	0	0	0	0	0	0		
	Red(255)	1	1	1	1	1	1	1	1	0	0	0	0	0	0	0	0	0	0	0	0	0	0		
Gray Scale Of Green	Green(0) / Dark	0	0	0	0	0	0	0	0	0	0	0	0	0	0	0	0	0	0	0	0	0	0		
	Green(1)	0	0	0	0	0	0	0	0	0	0	0	0	0	0	1	0	0	0	0	0	0	0		
	Green(2)	0	0	0	0	0	0	0	0	0	0	0	0	0	1	0	0	0	0	0	0	0	0		
	:	:	:	:	:	:	:	:	:	:	:	:	:	:	:	:	:	:	:	:	:	:	:		
	:	:	:	:	:	:	:	:	:	:	:	:	:	:	:	:	:	:	:	:	:	:	:		
	Green(253)	0	0	0	0	0	0	0	0	1	1	1	1	1	1	0	1	0	0	0	0	0	0		
	Green(254)	0	0	0	0	0	0	0	0	1	1	1	1	1	1	1	0	0	0	0	0	0	0		
	Green(255)	0	0	0	0	0	0	0	0	1	1	1	1	1	1	1	1	0	0	0	0	0	0		
Gray Scale Of Blue	Blue(0) / Dark	0	0	0	0	0	0	0	0	0	0	0	0	0	0	0	0	0	0	0	0	0	0		
	Blue(1)	0	0	0	0	0	0	0	0	0	0	0	0	0	0	0	0	0	0	0	0	0	1		
	Blue(2)	0	0	0	0	0	0	0	0	0	0	0	0	0	0	0	0	0	0	0	0	0	1		
	:	:	:	:	:	:	:	:	:	:	:	:	:	:	:	:	:	:	:	:	:	:	:		
	:	:	:	:	:	:	:	:	:	:	:	:	:	:	:	:	:	:	:	:	:	:	:		
	Blue(253)	0	0	0	0	0	0	0	0	0	0	0	0	0	0	0	1	1	1	1	1	1	0		
	Blue(254)	0	0	0	0	0	0	0	0	0	0	0	0	0	0	0	1	1	1	1	1	1	0		
	Blue(255)	0	0	0	0	0	0	0	0	0	0	0	0	0	0	0	1	1	1	1	1	1	1		

11. Interface Timing

11.1 Input Signal Characteristics

Item	Symbol	Values			Unit	Remark
		Min.	Typ.	Max.		
HS setup time	T_{hst}	8	-	-	ns	
HS hold time	T_{hhd}	8	-	-	ns	
VS setup time	T_{vst}	8	-	-	ns	
VS hold time	T_{vhd}	8	-	-	ns	
Data setup time	T_{dsu}	8	-	-	ns	
Data hole time	T_{dhd}	8	-	-	ns	
DE setup time	T_{esu}	8	-	-	ns	
DE hole time	T_{ehd}	8	-	-	ns	
DV _{DD} Power On Slew rate	T_{POR}	-	-	20	ms	From 0 to 90% DV _{DD}
RESET pulse width	T_{Rst}	1	-	-	ms	
DCLK cycle time	T_{coh}	20	-	-	ns	
DCLK pulse duty	T_{cwh}	40	50	60	%	

Input Clock and Data Timing Diagram

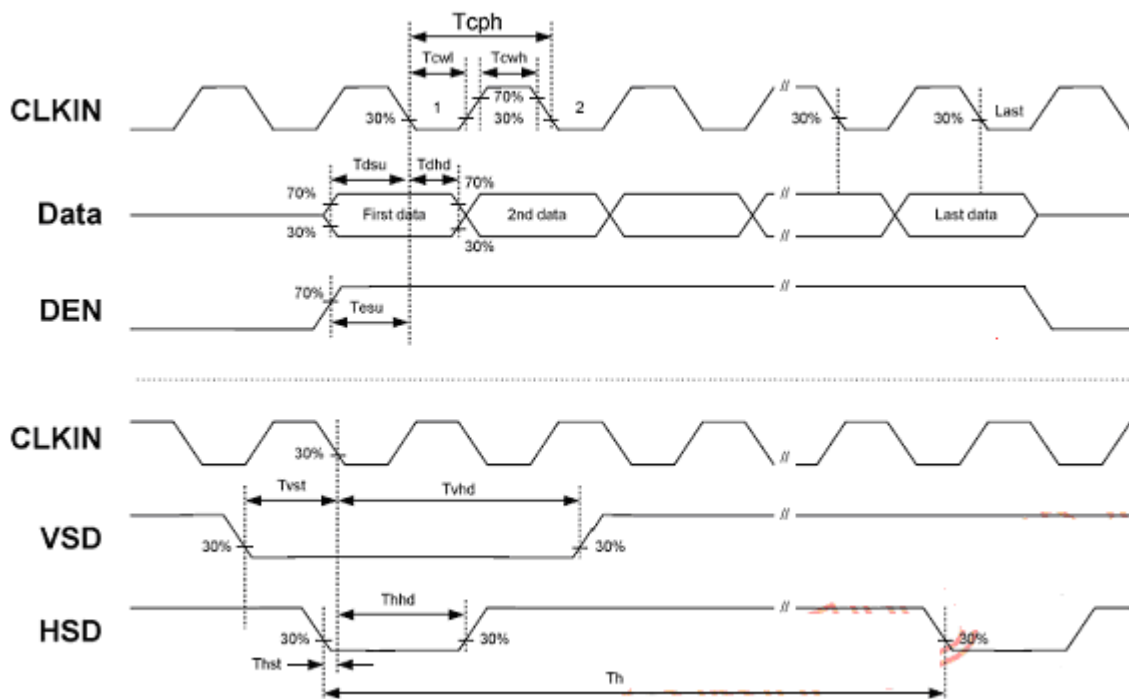

11.2 Power Sequence

Power on:

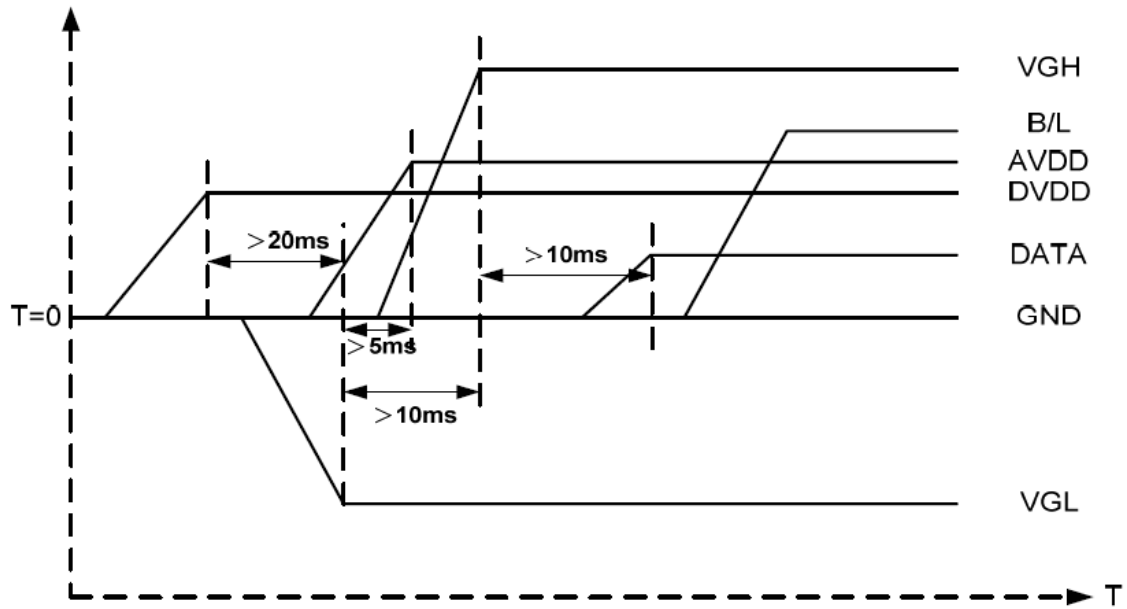

DV_{DD} → VGL → AVDD → VGH → Data → B/L

Power off:

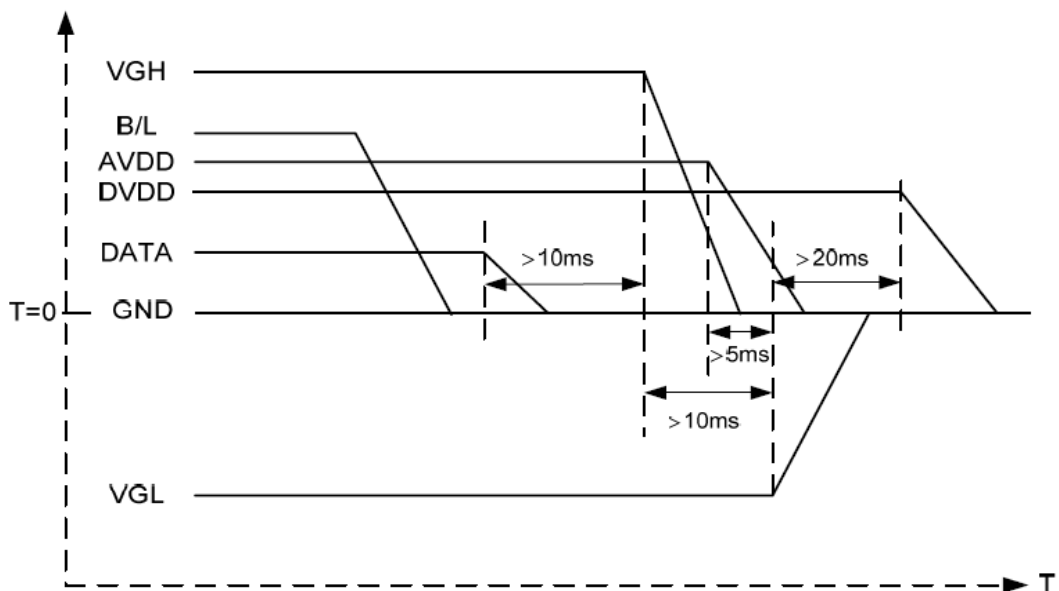

B/L → Data → VGH → AVDD → VGL → DV_{DD}

Note: Data include R0~R7, B0~B7, GO~G7, U/D, L/R, DCLK, HS, VS, DE.

EVERVISION	MODEL NO.		PAGE
	VGG804818-6UFLWC	SPEC SAMPLE	17

11.3 Timing

Item	Symbol	Values			Unit	Remark
		Min.	Typ.	Max.		
Horizontal Display Area	thd	-	800	-	DCLK	
DCLK Frequency	fclk	26.4	33.3	46.8	MHz	
One Horizontal Line	th	862	1056	1200	DCLK	
HS pulse width	thpw	1	-	40	DCLK	
HS Blanking	thb	46	46	46	DCLK	
HS Front Porch	thfp	16	210	354	DCLK	

Item	Symbol	Values			Unit	Remark
		Min.	Typ.	Max.		
Vertical Display Area	tvd	-	480	-	TH	
VS period time	tv	510	525	650	TH	
VS pulse width	tvpw	1	-	20	TH	
VS Blanking	tvb	23	23	23	TH	
VS Front Porch	tvfp	7	22	147	TH	

11.4 Waveform

11.4.1 Data input format



Horizontal input timing diagram.

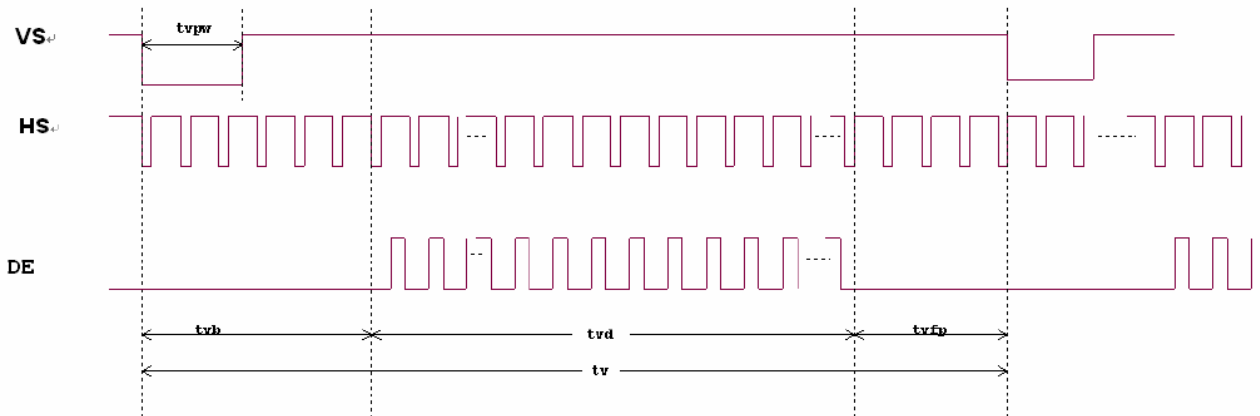

Vertical input timing diagram.

11.5 Timing Requirement of Improved Projected Capacitive Touch

11.5.1 I2C Data Transfer Format

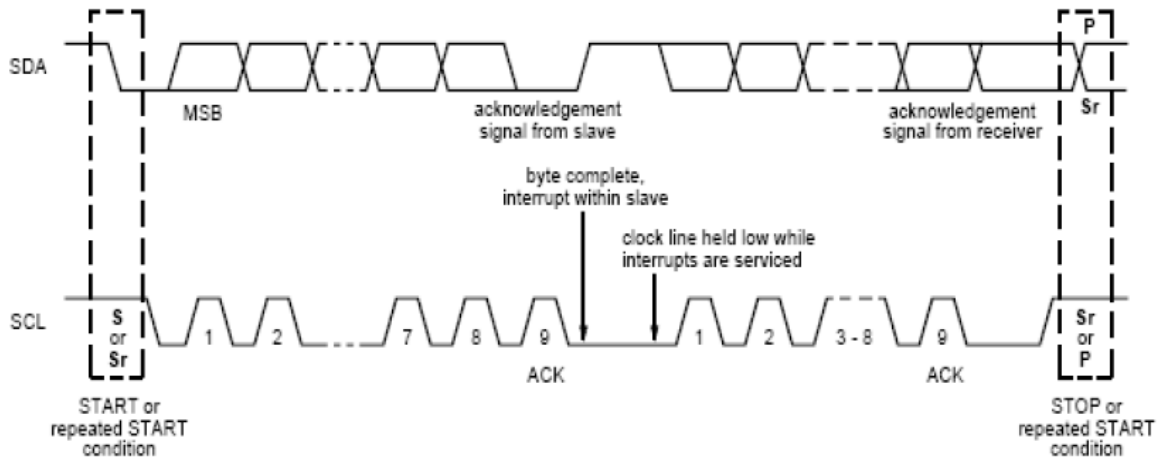

Mnemonics	Description
S	I ² C Start or I ² C Restart
A[6:0]	Slave Address = 7'b0111000
W	1'b0: Write
R	1'b1: Read
C	ACK
P	STOP: the indicate the end of a packet (if this bit is missing, S will indicate the end of the current packet and the beginning of the next packet)

Write N bytes to I2C slave

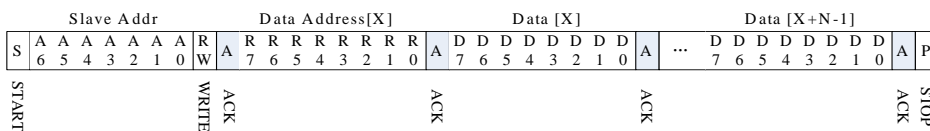

Set Data Address

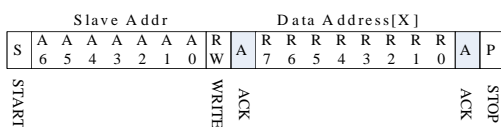

Read X bytes from I²C Slave

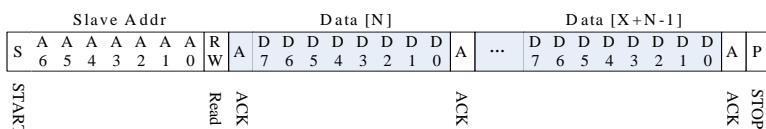

11.5.2 I2C Timing Characteristics

(Ta=25±2°C)

Parameter	Min	Max	Unit
SCL frequency	-	400	kHz
Bus free time between a STOP and START condition	4.7	-	μs
Hold time (repeated) START condition	4.0	-	μs
Data setup time	250	-	ns
Setup time for a repeated START condition	4.7	-	μs
Setup time for STOP condition	4.0	-	μs

11.5.3 Interrupt Trigger Mode

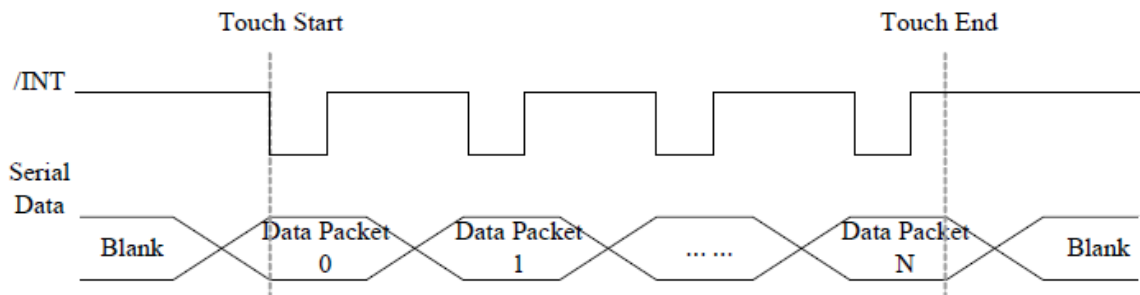

11.5.4 I2C Operating Mode Register Map

Address	Name	Bit 7	Bit 6	Bit 5	Bit 4	Bit 3	Bit 2	Bit 1	Bit 0	Host Access
Op,00h	DEVICE_MODE		Device Mode[2:0]							RW
Op,01h	Reserved									R
Op,02h	TD_STATUS					Number of touch points[3:0]				R
Op,03h	TOUCH1_YH	1 st Event Flag				1 st Touch Y Position[11:8]				R
Op,04h	TOUCH1_YL	1 st Touch Y Position[7:0]								R
Op,05h	TOUCH1_XH	1 st Touch ID[3:0]				1 st Touch X Position[11:8]				R
Op,06h	TOUCH1_XL	1 st Touch X Position[7:0]								R
Op,07h	Reserved									R
Op,08h	Reserved									R
Op,09h	TOUCH2_YH	2 nd Event Flag				2 nd Touch Y Position[11:8]				R

EVERVISION	MODEL NO.		PAGE
	VGG804818-6UFLWC	SPEC SAMPLE	21

Op,0Ah	TOUCH2_YL	2 nd touch Y Position[7:0]		R
Op,0Bh	TOUCH2_XH	2 nd Touch ID[3:0]	2 nd Touch X Position[11:8]	R
Op,0Ch	TOUCH2_XL	2 nd Touch X Position[7:0]		R
Op,0Dh	Reserved			R
Op,0Eh	Reserved			R
Op,0Fh	TOUCH3_YH	3 rd Event Flag	3 rd Touch Y Position[11:8]	R
Op,10h	TOUCH3_YL	3 rd Touch Y Position[7:0]		R
Op,11h	TOUCH3_XH	3 rd Touch ID[3:0]	3 rd Touch X Position[11:8]	R
Op,12h	TOUCH3_XL	3 rd Touch X Position[7:0]		R
Op,13h	Reserved			R
Op,14h	Reserved			R
Op,15h	TOUCH4_YH	4 th Event Flag	4 th Touch Y Position[11:8]	R
Op,16h	TOUCH4_YL	4 th Touch Y Position[7:0]		R
Op,17h	TOUCH4_XH	4 th Touch ID[3:0]	4 th Touch X Position[11:8]	R
Op,18h	TOUCH4_XL	4 th Touch X Position[7:0]		R
Op,19h	Reserved			R
Op,1Ah	Reserved			R
Op,1Bh	TOUCH5_YH	5 th Event Flag	5 th Touch Y Position[11:8]	R
Op,1Ch	TOUCH5_YL	5 th Touch Y Position[7:0]		R
Op,1Dh	TOUCH5_XH	5 th Touch ID[3:0]	5 th Touch X Position[11:8]	R
Op,1Eh	TOUCH5_XL	5 th Touch X Position[7:0]		R
Op,1Fh	Reserved			R
Op,20h	Reserved			R
Op,21h	TOUCH6_YH	6 th Event Flag	6 th Touch Y Position[11:8]	R
Op,22h	TOUCH6_YL	6 th Touch Y Position[7:0]		R
Op,23h	TOUCH6_XH	6 th Touch ID[3:0]	6 th Touch X Position[11:8]	R
Op,24h	TOUCH6_XL	6 th Touch X Position[7:0]		R
Op,25h	Reserved			R
Op,26h	Reserved			R

EVERVISION	MODEL NO.		PAGE
	VGG804818-6UFLWC	SPEC SAMPLE	22

Op,27h	TOUCH7_YH	7 th Event Flag	7 th Touch Y Position[11:8]	R
Op,28h	TOUCH7_YL	7 th Touch Y Position[7:0]		R
Op,29h	TOUCH7_XH	7 th Touch ID[3:0]	7 th Touch X Position[11:8]	R
Op,2Ah	TOUCH7_XL	7 th Touch X Position[7:0]		R
Op,2Bh	Reserved			R
Op,2Ch	Reserved			R
Op,2Dh	TOUCH8_YH	8 th Event Flag	8 th Touch Y Position[11:8]	R
Op,2Eh	TOUCH8_YL	8 th Touch Y Position[7:0]		R
Op,2Fh	TOUCH8_XH	8 th Touch ID[3:0]	8 th Touch X Position[11:8]	R
Op,30h	TOUCH8_XL	8 th Touch X Position[7:0]		R
Op,31h	Reserved			R
Op,32h	Reserved			R
Op,33h	TOUCH9_YH	9 th Event Flag	9 th Touch Y Position[11:8]	R
Op,34h	TOUCH9_YL	9 th Touch Y Position[7:0]		R
Op,35h	TOUCH9_XH	9 th Touch ID[3:0]	9 th Touch X Position[11:8]	R
Op,36h	TOUCH9_XL	9 th Touch X Position[7:0]		R
Op,37h	Reserved			R
Op,38h	Reserved			R
Op,39h	TOUCH10_YH	10 th Event Flag	10 th Touch Y Position[11:8]	R
Op,3Ah	TOUCH10_YL	10 th Touch Y Position[7:0]		R
Op,3Bh	TOUCH10_XH	10 th Touch ID[3:0]	10 th Touch X Position[11:8]	R
Op,3Ch	TOUCH10_XL	10 th Touch X Position[7:0]		R
Op,3Dh	Reserved			R
Op,3Eh	Reserved			R

11.5.5 DEVICE_MODE

This register is the device mode register, configure it to determine the current mode of the chip.

Address	Bit Address	Register Name	Description
Op,00h	6:4	Device Mode [2:0]	000b Normal operating Mode 001b System Information Mode (Reserved) 100b Test Mode – read raw data (Reserved)

11.5.6 TD_STATUS

This register is the Touch Data status register.

Address	Bit Address	Register Name	Description
Op,02h	3:0	Number of touch points[3:0]	How many points detected. 1-10 is valid.

11.5.7 TOUCHn_YH (n:1-10)

This register describes MSB of the Y coordinate of the nth touch point and the corresponding event flag.

Address	Bit Address	Register Name	Description
Op,03h ~ Op,39h	7:6	Event Flag	00b: Put Down 01b: Put Up 10b: Contact 11b: No event
	5:4		Reserved
	3:0	Touch Y Position [11:8]	MSB of Touch Y Position in pixels

11.5.8 TOUCHn_YL (n:1-10)

This register describes LSB of the Y coordinate of the nth touch point.

Address	Bit Address	Register Name	Description
Op,04h ~ Op,3Ah	7:0	Touch Y Position [7:0]	LSB of the Touch Y Position in pixels

11.5.9 TOUCHn_XH (n:1-10)

This register describes MSB of the X coordinate of the nth touch point and corresponding touch ID.

Address	Bit Address	Register Name	Description
Op,05h ~ Op,3Bh	7:4 3:0	Touch ID[3:0] Touch X Position [11:8]	Touch ID of Touch Point MSB of Touch X Position in pixels

11.5.10 TOUCHn_XL (n:1-10)

This register describes LSB of the X coordinate of the nth touch point.

Address	Bit Address	Register Name	Description
Op,06h ~ Op,3Ch	7:0	Touch X Position [7:0]	LSB of The Touch X Position in pixels

11.6 POWER ON/Reset Sequence

Reset should be pulled down to be low before powering on and powering down. I2C shouldn't be used by other devices during Reset time after VDD powering on (Trtp). INT signal will be sent to the host after initializing all parameters and then start to report points to the host. If Power is down, the voltage of supply must be below 0.3V and Tpd is more than 1ms.

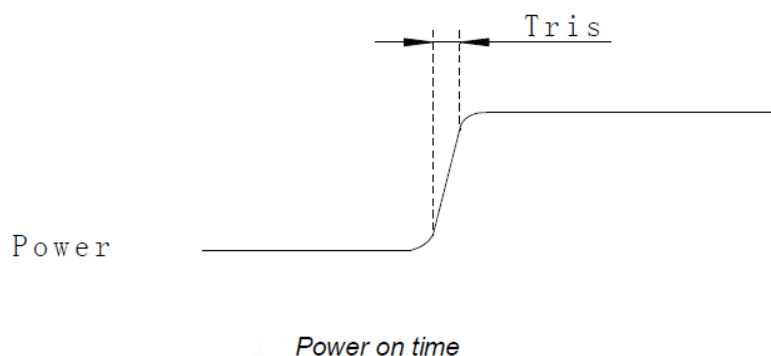

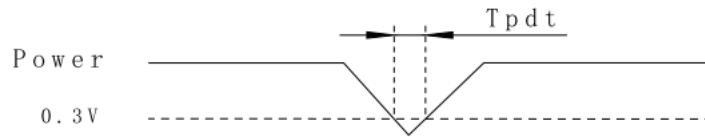

Power Cycle requirement

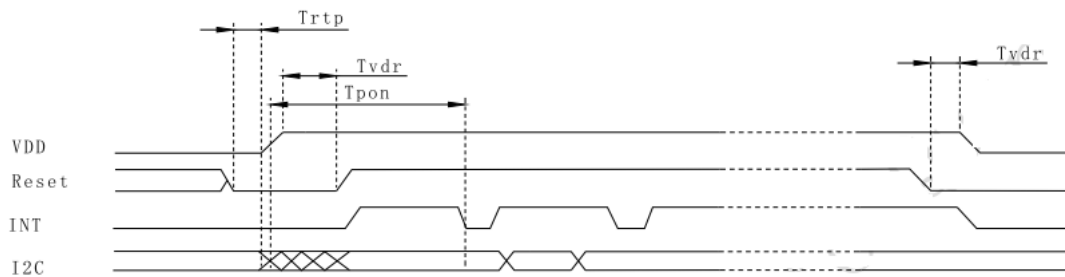

Power on Sequence

Reset time must be enough to guarantee reliable reset, the time of starting to report point after resetting approach to the time of starting to report point after powering on.

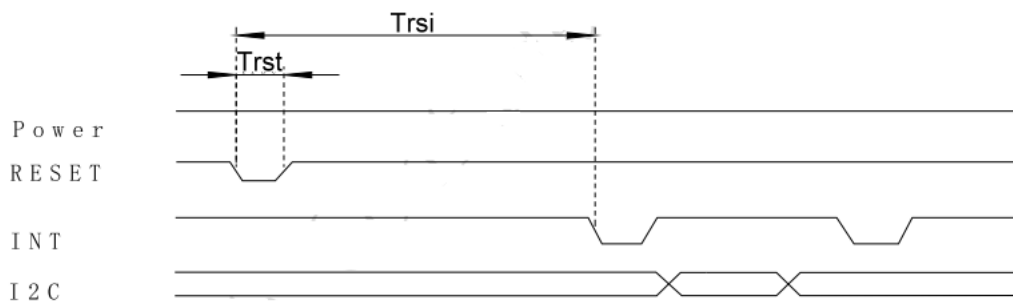

Reset Sequence

Power on/Reset Sequence Parameters

Parameter	Description	Min	Max	Units
Tris	Rise time from 0.1VDD to 0.9VDD	--	5	ms
Tpd t	Time of the voltage of supply being below 0.3V	5	--	ms
Trtp	Time of resetting to be low before powering on	100	--	μs
Tpon	Time of starting to report point after powering on	--	200	ms
Tvd r	Reset time after VDD powering on	1	--	ms
Trsi	Time of starting to report point after resetting	--	200	ms
Trst	Reset time	1	--	ms

12. Optical Characteristics

The optical characteristics should be measured in a dark environment (≤ 1 lux) or equivalent state with the methods shown in Note (4).

Item		Symbol	Conditions	Min.	Typ.	Max.	Unit	Note
Contrast Ratio		CR	$\theta_x=0^\circ, \theta_y=0^\circ$ Viewing Normal Angle	400	(500)	-	-	(2)
Response Time		T_R		-	10	20	ms	(3)
		T_F		-	15	30	ms	
Luminance(Center)		Y		280	(350)	-	cd/m ²	(4)
Brightness uniformity		BUNI		70	(75)	-	%	(5)
Color Chromaticity	White	W_x	0.26	0.31	0.36	-	(1),(4)	
		W_y	0.28	0.33	0.38	-		
Viewing Angle	Horizontal	θ_{x+}	$CR \geq 10$	60	(70)	-	deg.	
		θ_{x-}		60	(70)	-		
	Vertical	θ_{y+}		40	(50)	-		
		θ_{y-}		60	(70)	-		

Note (1) Definition of Viewing Angle (θ_x , θ_y):

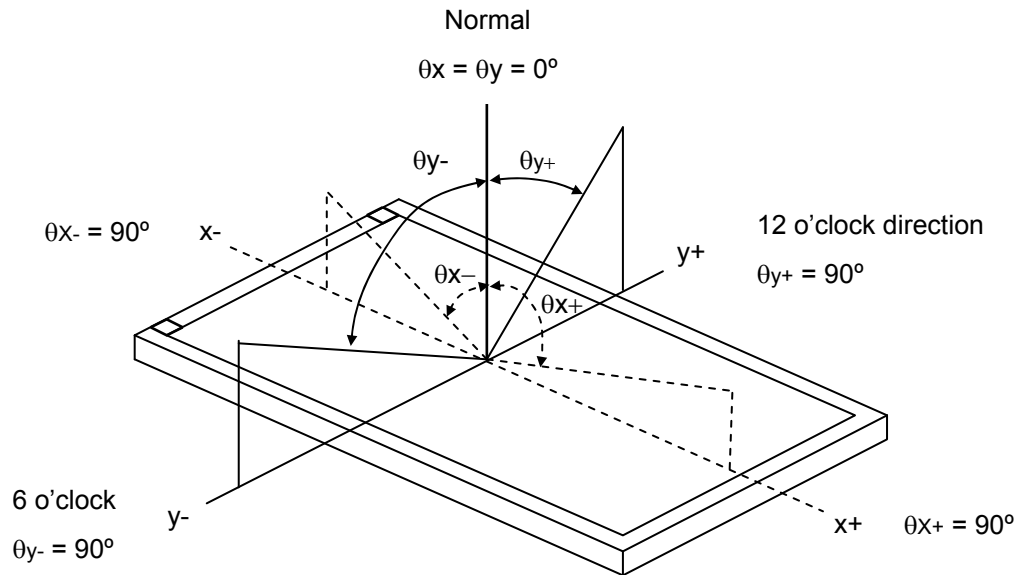

Note (2) Definition of Contrast Ratio (CR):

$$\text{Contrast ratio (CR)} = \frac{\text{Luminance measured when LCD on the "White" state}}{\text{Luminance measured when LCD on the "Black" state}}$$

Note (3) Definition of Response Time (T_R , T_F):

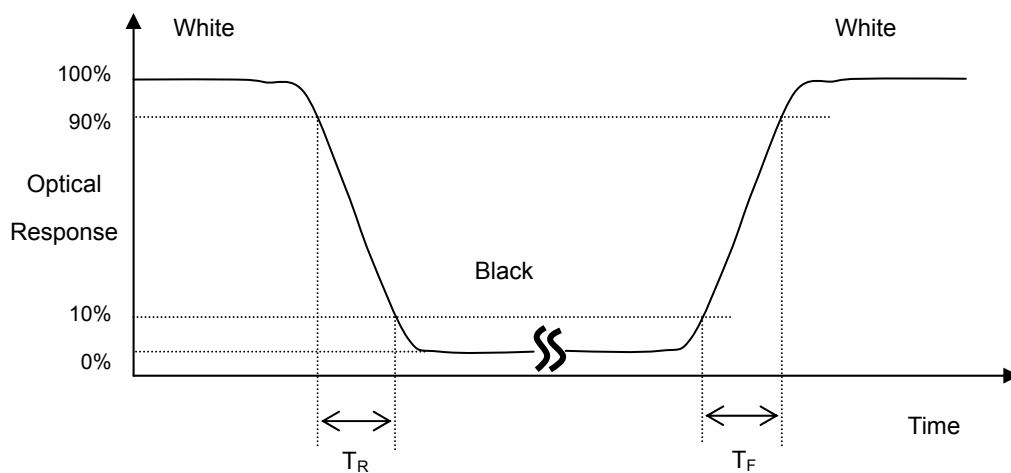

Note (4) Measurement Set-Up:

The LCD module should be stabilized at a given temperature for 30 minutes to avoid abrupt temperature change during measuring. In order to stabilize the luminance, the measurement should be executed after lighting Backlight for 30 minutes in a dark room or equivalent condition.

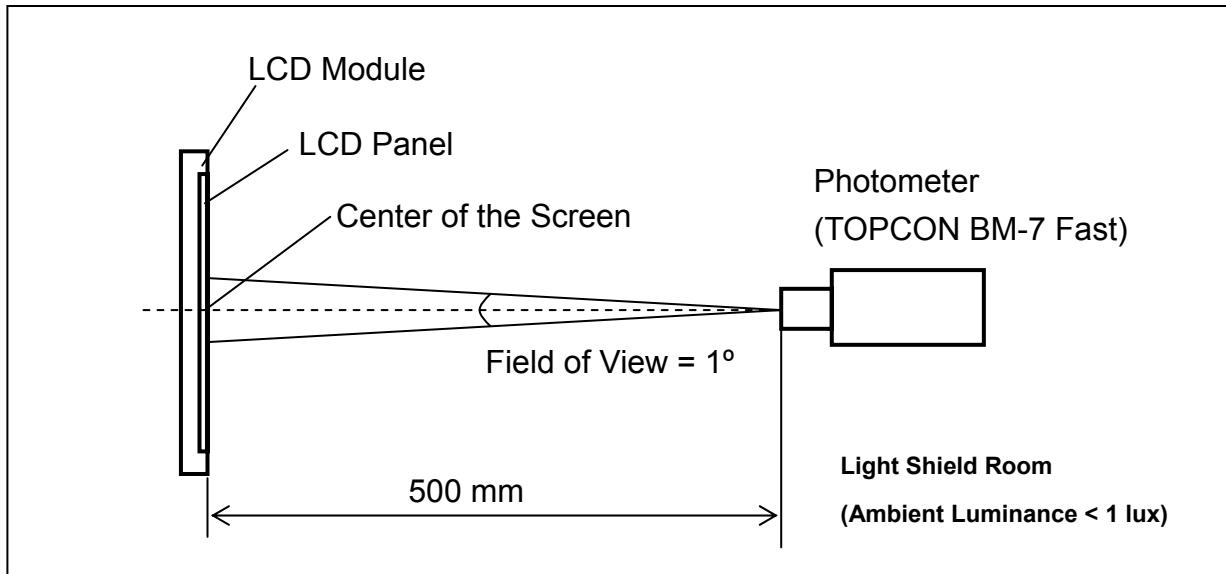

Note (5) Definition of brightness uniformity

$$\text{Brightness uniformity} = (\text{Min Luminance of 9 points}) / (\text{Max Luminance of 9 points}) \times 100\%$$

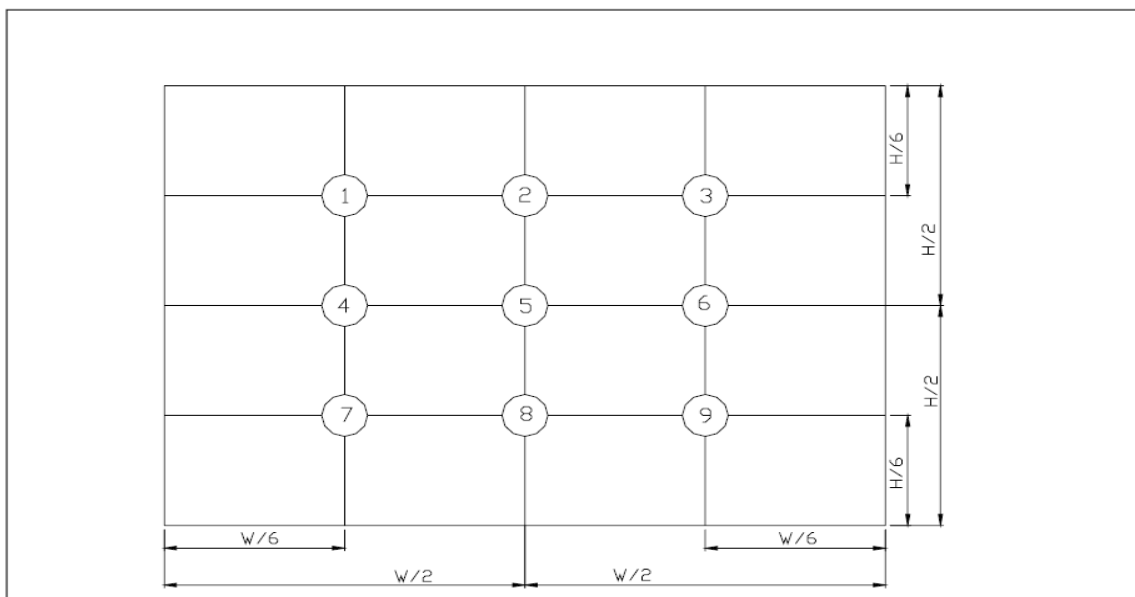

(單位 : mm)

EVERVISION	MODEL NO.		PAGE
	VGG804818-6UFLWC	SPEC SAMPLE	29

13. Reliability Test

Test Items	Test Condition	Remark
High Temperature Storage	Ta = 80°C 240hrs	Note 1,Note 4
Low Temperature Storage	Ta = -30°C 240hrs	Note 1,Note 4
High Temperature Operation	Ts = 70°C 240hrs	Note 2,Note 4
Low Temperature Operation	Ta = -20°C 240hrs	Note 1,Note 4
Operate at High Temperature and Humidity	+60°C , 90%RH 240 hrs	Note 4
Thermal Shock	-20°C/30 min ~ +70°C/30 min for a total 10 cycles, Start with cold temperature and end with high temperature	Note 4
Vibration Test	Frequency range:10~55Hz Stroke:1.5mm Sweep:10Hz~55Hz~10Hz 2 hours for each direction of X. Y. Z. (6 hours for total)	
Mechanical Shock	100G 6ms,±X, ±Y, ±Z 3 times for each direction	
Package Vibration Test	Random Vibration : 0.015G*G/Hz from 5-200HZ, -6dB/Octave from 200-500HZ 2 hours for each direction of X. Y. Z. (6 hours for total)	
Package Drop Test	Height:60 cm 1 corner, 3 edges, 6 surfaces	
Electro Static Discharge	± 2KV, Human Body Mode, 100pF/1500Ω	

Note 1: Ta is the ambient temperature of samples.

Note 2: Ts is the temperature of panel's surface.

Note 3: In the standard condition, there shall be no practical problem that may affect the display function. After the reliability test, the product only guarantees operation, but don't guarantee all of the cosmetic specification.

Note 4: Before cosmetic and function tests, the product must have enough recovery time, at least 2 hours at room temperature.

14. Packaging

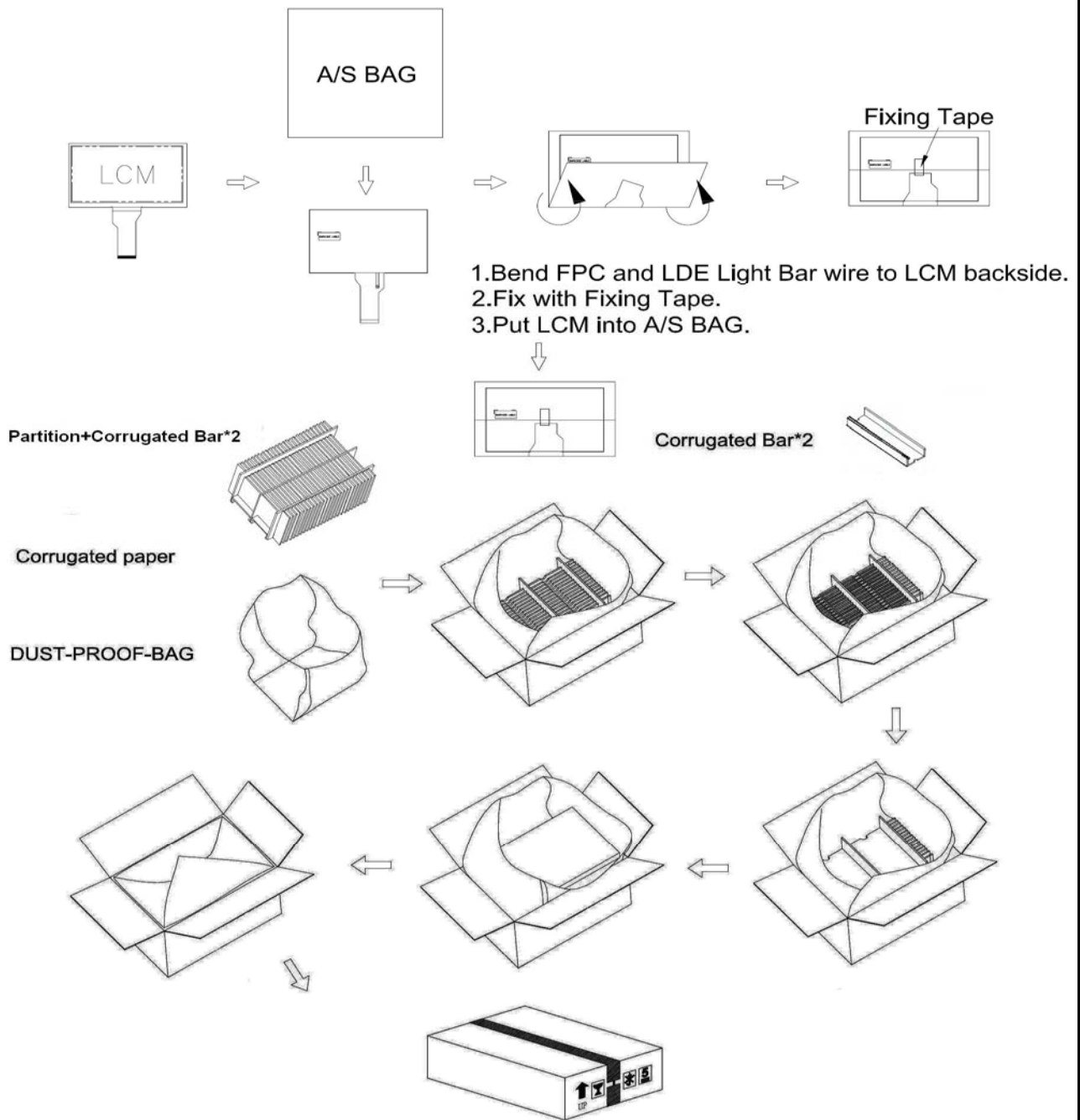

PARTS LIST					
	ITEM	SIZE(L×W×H) unit : mm	MATERIAL	Q.T.Y	NOTE
1	PARTITION	512.0×349.0×226.0	CORRUGATED PAPER	1	
2	CORRUGATED PAPER	510.0×350.0	CORRUGATED PAPER	4	
3	CORRUGATED BAR	512.0×11.0×3.0	CORRUGATED PAPER	4	
4	DUST-PROOF BAG	700.0×530.0	PE	1	
5	A/S BAG	180.0×133.0×0.2	PE	50	
6	CARTON	530.0×355.0×255.0	CORRUGATED PAPER	1	
7	PRODUCT	164.9×100.0×7.25		50	

EVERVISION	MODEL NO.		PAGE
	VGG804818-6UFLWC	SPEC SAMPLE	31

15. Precautions

15.1 Assembly and Handling Precautions

- (1) Do not apply rough force such as bending or twisting to the module during assembly.
- (2) It's recommended to assemble or to install a module into the user's system in clean working areas. The dust and oil may cause electrical short or worsen the polarizer.
- (3) Don't apply pressure or impulse to the module to prevent the damage of LCD panel and Backlight.
- (4) Always follow the correct power-on sequence when the LCD module is turned on. This can prevent the damage and latch-up of the CMOS LSI chips.
- (5) Do not plug in or pull out the I/F connector while the module is in operation.
- (6) Do not disassemble the module.
- (7) Use a soft dry cloth without chemicals for cleaning, because the surface of polarizer is very soft and easily scratched.
- (8) Moisture can easily penetrate into LCD module and may cause the damage during operation.
- (9) High temperature or humidity may deteriorate the performance of LCD module. Please store LCD module in the specified storage conditions.
- (10) When ambient temperature is lower than 10°C, the display quality might be reduced. For example, the response time will become slow.

15.2 Safety Precautions

- (1) If the liquid crystal material leaks from the panel, it should be kept away from the eyes or mouth. In case of contact with hands, skin or clothes, it has to be washed away thoroughly with soap.
- (2) After the module's end of life, it is not harmful in case of normal operation and storage.

15.3 Terms of Warrant

- (1) Acceptance inspection period
The period is within one month after the arrival of contracted commodity at the buyer's factory site.
- (2) Applicable warrant period
The period is within twelve months since the date of shipping out under normal using and storage conditions.

EVERVISION	MODEL NO.		PAGE
	VGG804818-6UFLWC	SPEC SAMPLE	32

15.4 Cautions for LCM's installing and assembling

Please keep away the FPC while assembling or fixing the LCM to avoid FPC being damaged or extruded or other related problems. Please see below picture.

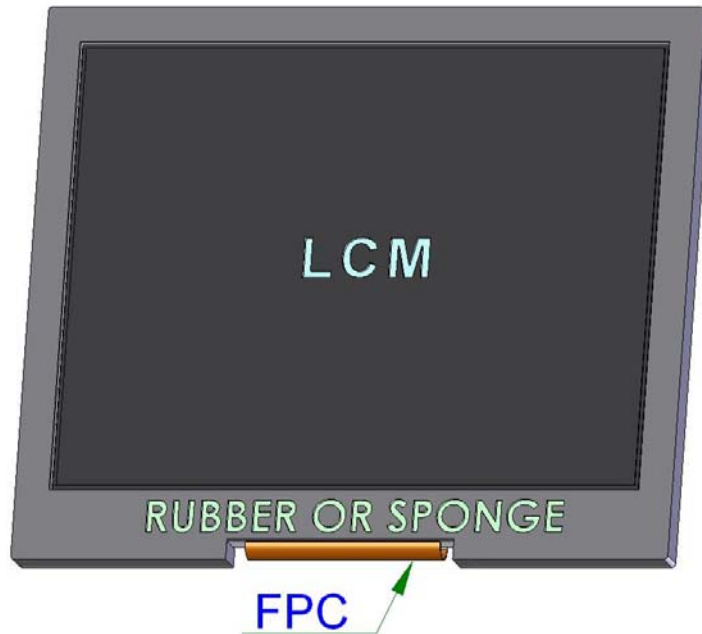

15.5 Caution

This Evervision LCD module has been specifically designed for use only in electronic devices in the areas of audio control, office automation, industrial control, home appliances, etc. The modules should not be used in applications where module failure could result in physical harm or loss of life, and Evervision expressly disclaims any and all liability relating in any way to the use of the module in such applications.

15.6 Cautions for LCM installation

To secure the LCM within customer housing, having appropriate structural support underneath the LCM is a must. The recommended LCM installation with a holder type of the structure into the customer housing is shown below figure. By attaching ONLY the protruding edges of the PCT with cover lens onto the customer housing does not provide a proper structural support required for the LCM. Such construction may deteriorate the adhesivity between the PCT with cover lens and the TFT module, especially after a long period of time or from the vibrations encountered during product transportation.

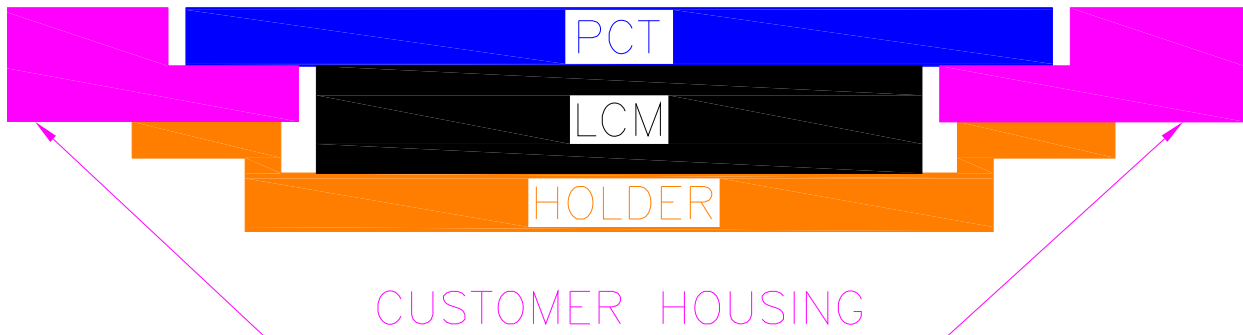

16.Outline Drawing

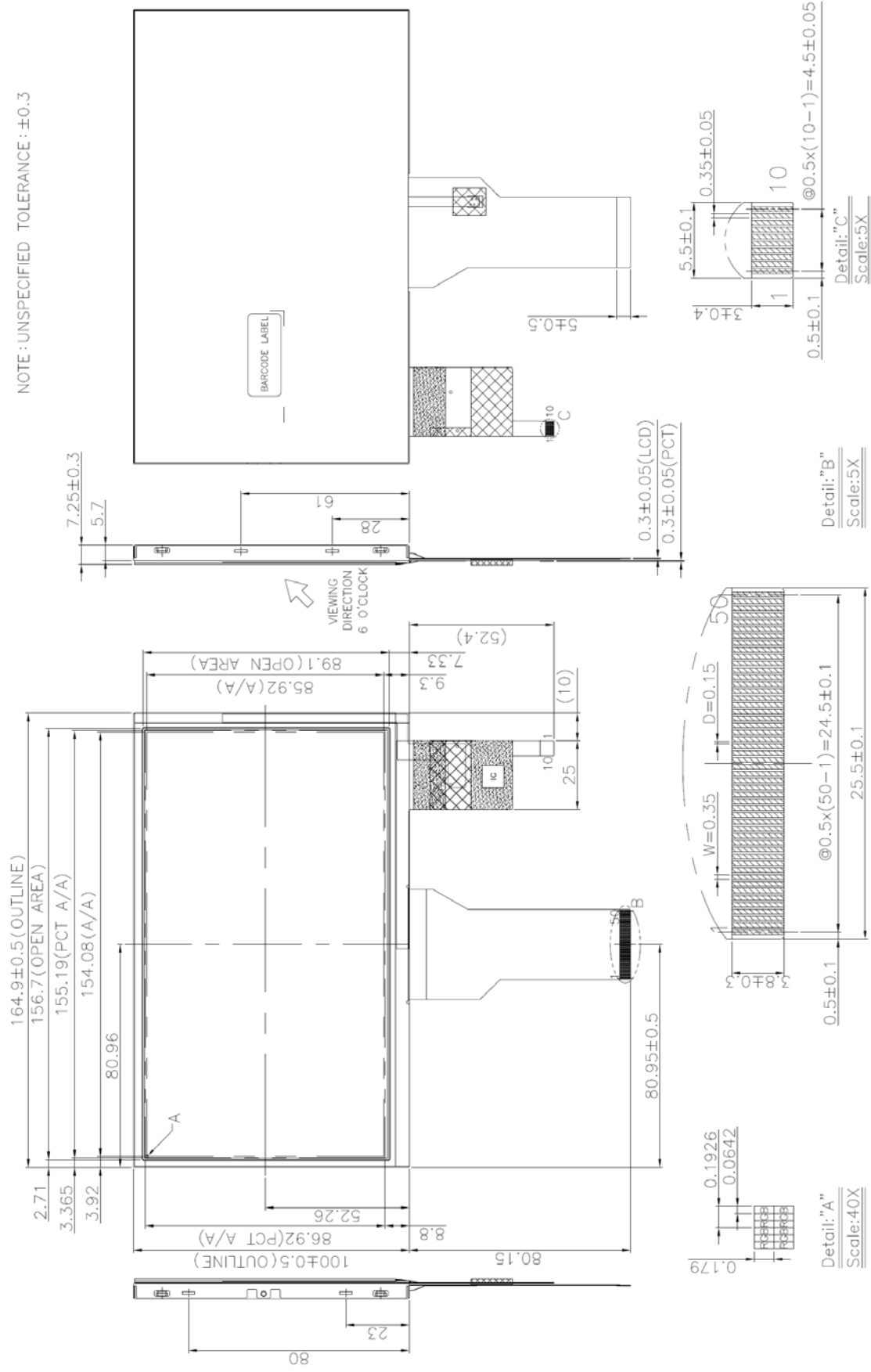

EVERVISION	MODEL NO.		PAGE
	VGG804818-6UFLWC	SPEC SAMPLE	35

17. Definition of Labels

The bar code nameplate is pasted on each module as illustration, and its definitions are as following explanation.



- (a) Module Name : VGG804818-6UFLWC
- (b) Serial ID :

A B C D E F G H I J K L

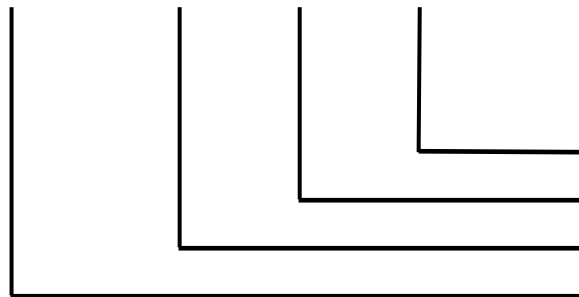

Serial No.
Factory Code
Manufactured Date
Screen Size

Serial ID includes the information as below :

- (a) Screen size (Diagonal) : Inch Code (ABCD)
3.5" → 0350
10.4" → 1040
- (b) Manufactured Date : Year, Month, Day (EFG)

Year (E)

Year	2000	2001	2002	2003	2004	2005	2006	2007	2008	2009
Mark	0	1	2	3	4	5	6	7	8	9
Year	2010	2011	2012	2013	2014	2015	2016	2017	2018	2019
Mark	A	B	C	D	E	F	G	H	I	J

EVERVISION	MODEL NO.		PAGE
	VGG804818-6UFLWC	SPEC SAMPLE	36

Month (F)

Month	Jan.	Feb.	Mar.	Apr.	May	Jun.	Jul.	Aug.	Sep.	Oct.	Nov.	Dec.
Mark	1	2	3	4	5	6	7	8	9	A	B	C

Day (G)

Day	1	2	3	4	5	6	7	8	9	10	11	12	13	14	15	16
Mark	1	2	3	4	5	6	7	8	9	A	B	C	D	E	F	G
Day	17	18	19	20	21	22	23	24	25	26	27	28	29	30	31	
Mark	H	I	J	K	L	M	N	O	P	Q	R	S	T	U	V	

(c) Factory Code (H) :

For EVERVISION internal use.

(d) Serial No. (IJKL) :

Manufacturing sequence of product, for example : 0001~9999.

EVERVISION	MODEL NO.		PAGE
	VGG804818-6UFLWC	SPEC SAMPLE	37

18. Incoming Inspection Standards

18.1 Inspection Parameters

1. Incoming Inspection

Both parties agree that the inspection specifications of TFT-LCD Modules (hereinafter known as "Modules") stipulated hereunder is the only and final standard applicable in the process of inspection. EVERVISION shall be under no liability or obligation (including incidental loss, products liability or other consequential loss) whatsoever for any defect in quality or performance or shortage in quantity of the Modules that have passed such inspection.

2. Liability

2.1 Inspection Deadline

The Customer should inspect the Modules either at the Delivery Point or within twenty (20) calendar days after arrival at the Delivery Destination.

2.2 Notification of Rejection

The Customer may reject one or more defective or non-conforming Modules if the Modules fail to meet the AQL (Acceptable Quality Level) and pass the inspection. In that case, the customer should notify EVERVISION of the rejection by either documents or mail within in three (3) business days from the date of reception of the Modules. Otherwise, the Modules shall be deemed to have met the AQL and passed the inspection.

3. Inspection Specifications

Both parties agree that the inspection shall contain and follow the inspection specifications stipulated in the attachment, including :

- 3.1 Scope
- 3.2 Sampling Plan
- 3.3 Panel Inspection Condition
- 3.4 Display Quality
- 3.5 Mechanics Specifications
- 3.6 Notification for Storage Handling

4. Limited Warranty

EVERVISION represents and warrants that all Modules shall (i) conform to the specifications set hereunder, and (ii) be free from any defects in material and workmanship for twelve (12) months after the Customer's acceptance or deemed acceptance. EVERVISION will replace, rework or refund the Customer for the defective or non-conforming Modules at EVERVISION's option, provided that the Customer (i) promptly informs EVERVISION of the defects or non-conformities within the warranty period, (ii) complies with the specifications and conditions hereunder, and (iii) complies with EVERVISION's procedure for Modules replacement, reworking and/or return. The warranty period for the Modules replaced

EVERVISION	MODEL NO.		PAGE
	VGG804818-6UFLWC	SPEC SAMPLE	38

or reworked shall be the remaining term for such Modules.

5. THE WARRANTIES AND REMEDIES SET FORTH ABOVE ARE EXCLUSIVE AND IN LIEU OF ALL OTHER WARRANTIES, TERMS OR CONDITIONS, EXPRESS OR IMPLIED, EITHER IN FACT OR BY OPERATION OF LAW, STATUTORY OR OTHERWISE, INCLUDING WARRANTIES OR CONDITIONS OF MERCHANTABILITY AND FITNESS FOR A PARTICULAR PURPOSE, ALL OF WHICH ARE EXPRESSLY DISCLAIMED. EVERVISION'S WARRANTIES HEREIN APPLY ONLY TO THE CUSTOMER AND ARE NOT TO BE EXTENDED TO ANY THIRD PARTY.

6. Governing Law

This Agreement shall be governed and construed in accordance with the laws of the Republic of China. Both parties agree to submit any dispute, which cannot be amicably resolved, to Hsinchu District Court for the first instance.

EVERVISION	MODEL NO.		PAGE
	VGG804818-6UFLWC	SPEC SAMPLE	39

Inspection Specifications

1. Scope

Specifications contain

- 1.1 Display Quality Evaluation
- 1.2 Mechanics Specification

2. Sampling Plan

Unless there is other agreement, the sampling plan for incoming inspection shall follow MIL-STD-105E.

- 2.1 Lot size: Quantity per shipment as one lot (different model as different lot).
- 2.2 Sampling type: Normal inspection, single sampling.
- 2.3 Sampling level: Level II.
- 2.4 AQL: Acceptable Quality Level
 - Major defect: AQL=0.65
 - Minor defect: AQL=1.0

3. Panel Inspection Condition

3.1 Environment:

Room Temperature: $25 \pm 5^{\circ}\text{C}$.

Humidity: $65 \pm 5\%$ RH.

Illumination: 300 ~ 700 Lux.

3.2 Inspection Distance:

35 ± 5 cm

3.3 Inspection Angle:

The vision of inspector should be perpendicular to the surface of the Module.

3.4 Inspection time:

Perceptibility Test Time: 20 seconds max.

4. Display Quality

4.1 Function Related:

The function defects of line defect, abnormal display, and no display are considered Major defects.

4.2 Bright/Dark Dots :

Defect Type	Specification	Major	Minor
Bright Dots	$N \leq 2$		•
Dark Dots	$N \leq 3$		•
Total Bright and Dark Dots	$N \leq 4$		•

Note: 1: The definition of dot: The size of a defective dot over 1/2 of whole dot is regarded as one defective dot.

Bright dot: Dots appear bright and unchanged in size in which LCD panel is displaying under black pattern.

The bright dot defect must be visible through 2% ND filter

Dark dot: Dots appear dark and unchanged in size in which LCD panel is displaying under pure red, green, blue pattern.

4.3 Pixel Definition:

R		B	R	G	B	R	G	B		Dot Defect
R	G	B	R		B	R	G	B		Adjacent Dot Defect
			R	G		R	G	B		Cluster

Note

1: If pixel or partial sub-pixel defects exceed 50% of the affected pixel or sub-pixel area, it shall be considered as 1 defect.

Note 2: There should be no distinct non-uniformity visible through 2% ND Filter within 2 sec inspection times.

4.4 Visual Inspection specifications:

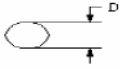
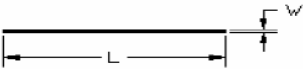
<u>Defect Type</u>		<u>Specification Size</u>	<u>Count(N)</u>	Major	Minor	
Dot Shape (Particle · Scratch and Bubbles in display area) 		$D \leq 0.25 \text{ mm}$	Ignored		•	
		$0.25\text{mm} < D \leq 0.5\text{mm}$	$N \leq 3$			
		$D > 0.5\text{mm}$	$N=0$			
Line Shape (Particles · Scratch · Lint and Bubbles in display area) 		$W \leq 0.01 \text{ mm}$	Ignored		•	
		$0.01\text{mm} < W \leq 0.05\text{mm}$ and $L \leq 3\text{mm}$	$N \leq 3$			
		$W > 0.05\text{mm}$ or $L > 3 \text{ mm}$	$N=0$			
Bubble in cell (active area)		It should be found by eyes			•	
Bezel	Scratch	No harm			•	
	Dirt				•	
	Wrap				•	
	Sunken				•	
Label	No label				•	
	Inverted label			No		•
	Broken					•
	Dirt	Word can be read.			•	
	Not clear	No			•	
	Word out of shape				•	
	Mistake	No		•		
	Position	Be attached on right position			•	
Screw	Not enough	No			•	
	Limp	No			•	

Incoming Inspection Touch Panel

Circular Defects

Linear Defects

Scratch

Air Bubble

Crack

(1) Circular Defects

$$\phi = (L+W)/2$$

Diameter(mm)	Spec
$\phi \leq 0.25$	No quantity limit
$0.25 < \phi \leq 0.5$	Max 5 defect
$0.5 < \phi$	Reject

(2) Linear Defects

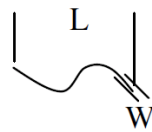

Length	Width	Acceptable
$12.0 \geq L$	$0.06 \geq W$	Accept
$12.0 \geq L$	$0.08 \geq W$	Max 5 defect
$L > 12.0$	$W > 0.08$	Reject

The Min distance of defects must be above 15.0mm.

Y:

Long breakage

Z:

Wide breakage

(3) Scratch

Length	Width	Acceptable
$12.0 \geq L$	$0.06 \geq W$	Accept
$12.0 \geq L$	$0.08 \geq W$	Max 5 defect
$L > 12.0$	$W > 0.08$	Reject

The Min distance of defects must be above 15.0mm.

D:

thickness
breakage

(4) Air Bubble

Diameter(mm)	Spec
$\phi \leq 0.2$	No quantity limit
$0.2 < \phi \leq 0.6$	Max 5 defect

The Min distance of defects must be above 10.0mm.

T:

single piece of
glass thickness
(Touch sensor
single thickness)

(5) Crack

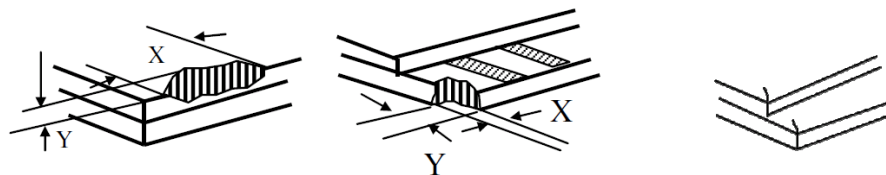

$$Z \leq T, X \leq 1/8 \text{ Sensor wide}$$

$$X \leq 3\text{mm and } Y \leq 1/3D$$

Y: Did not enter the VA

(Accept)

(Accept)

(Reject)

VA:

Touch control
panel viewing
area.

Sensor wide:

the size of the
long side of the
touch panel.

Note1.

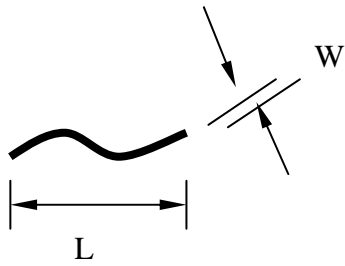

Note2.

D : Diameter $D = (a+b) / 2$

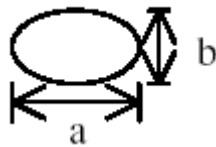

Note3.

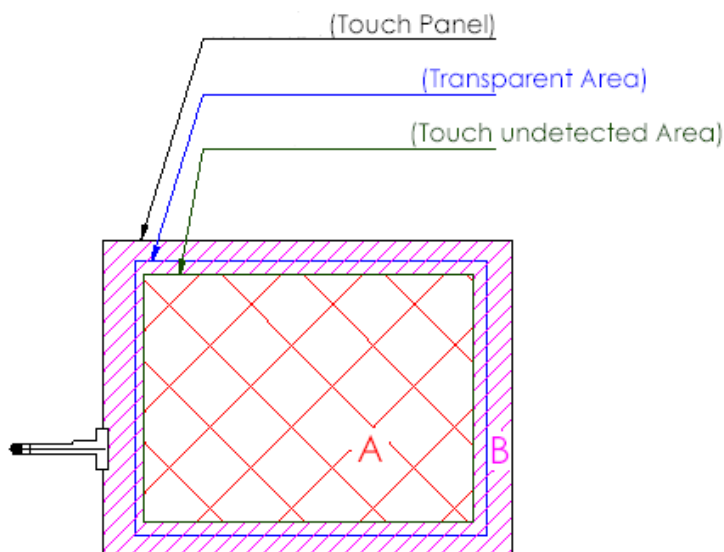

A area : Without any defect point effect on normal operation.

B area : None-specify

EVERVISION	MODEL NO.		PAGE
	VGG804818-6UFLWC	SPEC SAMPLE	44

Connector	Connection status	No bend on pins and damage		•
FPC/FFC	Broken	No		•

Note: Extraneous substance and scratch not affecting the display of image, for instance, extraneous substance under polarizer film but outside the display area, or scratch on metal bezel and backlight module or polarizer film outside the display area, shall not be considered as defective or non-conforming.

5. Mechanics specifications

As for the outside dimensions and weight of the Modules, please refer to product specifications for more details.

6. Notification for Storage Handling

6.1 Storage :

6.1.1 Environment condition must be within the product specifications, otherwise the Module might be damaged.

6.1.2 Pile of stacking shall follow the instruction of EVERVISION.

6.2 Handling :

6.2.1 Twisting or Bending of the Module is prohibited.

6.2.2 All chemicals are unfit for use unless otherwise instructed by EVERVISION.

6.2.3 Plugging in & unplugging :

The power must be turned off before plugging in or unplugging the Module.

6.2.4 ESD protection :

The Module must not be touched without proper grounding.

6.2.5 High Voltage :

The rear side of Module must not be touched without protection.

6.2.6 Power sequence :

Shall follow the instruction of EVERVISION.

EVERVISION	MODEL NO.		PAGE
	VGG804818-6UFLWC	SPEC SAMPLE	45

18.2 Handling of LCM

- (1) Don't give external shock.
- (2) Don't apply excessive force on the surface.
- (3) Liquid in LCD is hazardous substance. Must not lick and swallow. when the liquid is attach to your hand, skin, cloth etc. Wash it out thoroughly and immediately.
- (4) Don't operate it above the absolute maximum rating.
- (5) Don't disassemble the LCM.