

# LIQUID CRYSTAL DISPLAY MODULE

## Product Specification

<b>CUSTOMER</b>	<b>Standard</b>
<b>CUSTOMER PART NUMBER</b>	
<b>PRODUCT NUMBER</b>	<b>DET026QVNMNT0S-1A</b>

Product Mgr	Design Eng
<b>Bruno Recaldini</b>	<b>Sunny</b>
Date: 17-Dec-13	Date: 17-Dec-13

## TABLE OF CONTENTS

<b>1</b>	<b>MAIN FEATURES</b> .....	<b>4</b>
<b>2</b>	<b>MECHANICAL SPECIFICATION</b> .....	<b>5</b>
2.1	MECHANICAL CHARACTERISTICS.....	5
2.2	MECHANICAL DRAWING.....	6
<b>3</b>	<b>ELECTRICAL SPECIFICATION</b> .....	<b>7</b>
3.1	ABSOLUTE MAXIMUM RATINGS.....	7
3.2	ELECTRICAL CHARACTERISTICS.....	7
3.3	INTERFACE PIN ASSIGNMENT.....	8
3.4	TIMING CHARACTERISTICS .....	10
3.5	COMMAND TABLE .....	15
3.6	POWER SEQUENCE .....	17
<b>4</b>	<b>OPTICAL SPECIFICATION</b> .....	<b>19</b>
4.1	OPTICAL CHARACTERISTICS .....	19
<b>5</b>	<b>BACKLIGHT SPECIFICATION</b> .....	<b>21</b>
5.1	LED DRIVING CONDITIONS .....	21
<b>6</b>	<b>QUALITY ASSURANCE SPECIFICATION</b> .....	<b>22</b>
6.1	DELIVERY INSPECTION STANDARDS .....	22
6.2	DEALING WITH CUSTOMER COMPLAINTS.....	25
<b>7</b>	<b>RELIABILITY SPECIFICATION</b> .....	<b>26</b>
7.1	RELIABILITY TESTS.....	26
<b>8</b>	<b>HANDLING PRECAUTIONS</b> .....	<b>27</b>

**REVISION RECORD**

<b>Rev.</b>	<b>Date</b>	<b>Page</b>	<b>Chapt.</b>	<b>Comment</b>	<b>ECN no.</b>
1.0	17-Dec-13			Initial Release	

## 1 MAIN FEATURES

ITEM	CONTENTS
Screen Size	2.6" Diagonal
Display Format	240 x RGB x 320 Dots
N° of Colour	262K
Active Area	39.6 mm (H) x 52.8 mm (V)
LCD Type	TFT
Mode	IPS Transmissive / Normally Black
Viewing Direction	Full view
Interface	8/9/16/18-bits MCU interface; 16/18-bits RGB interface; 3/4-lines serial interface
Driver IC	ILI9341 or equivalent
Backlight Type	LED
Operating Temperature	-20°C ~ +70°C
Storage Temperature	-30°C ~ +80°C
RoHS compliant	Yes

## 2 MECHANICAL SPECIFICATION

### 2.1 MECHANICAL CHARACTERISTICS

---

ITEM	CHARACTERISTIC	UNIT
Display Format	240 x RGB x 320 Dots	Dots
Overall Dimensions	46.0 mm (H) x 64.0 mm (V) x 2.6 mm (D)	mm
Active Area	39.6 mm (H) x 52.8 mm (V)	mm
pixel Pitch	51 (H) x 51 (V)	μm
Weight	13	g

## 2.2 MECHANICAL DRAWING

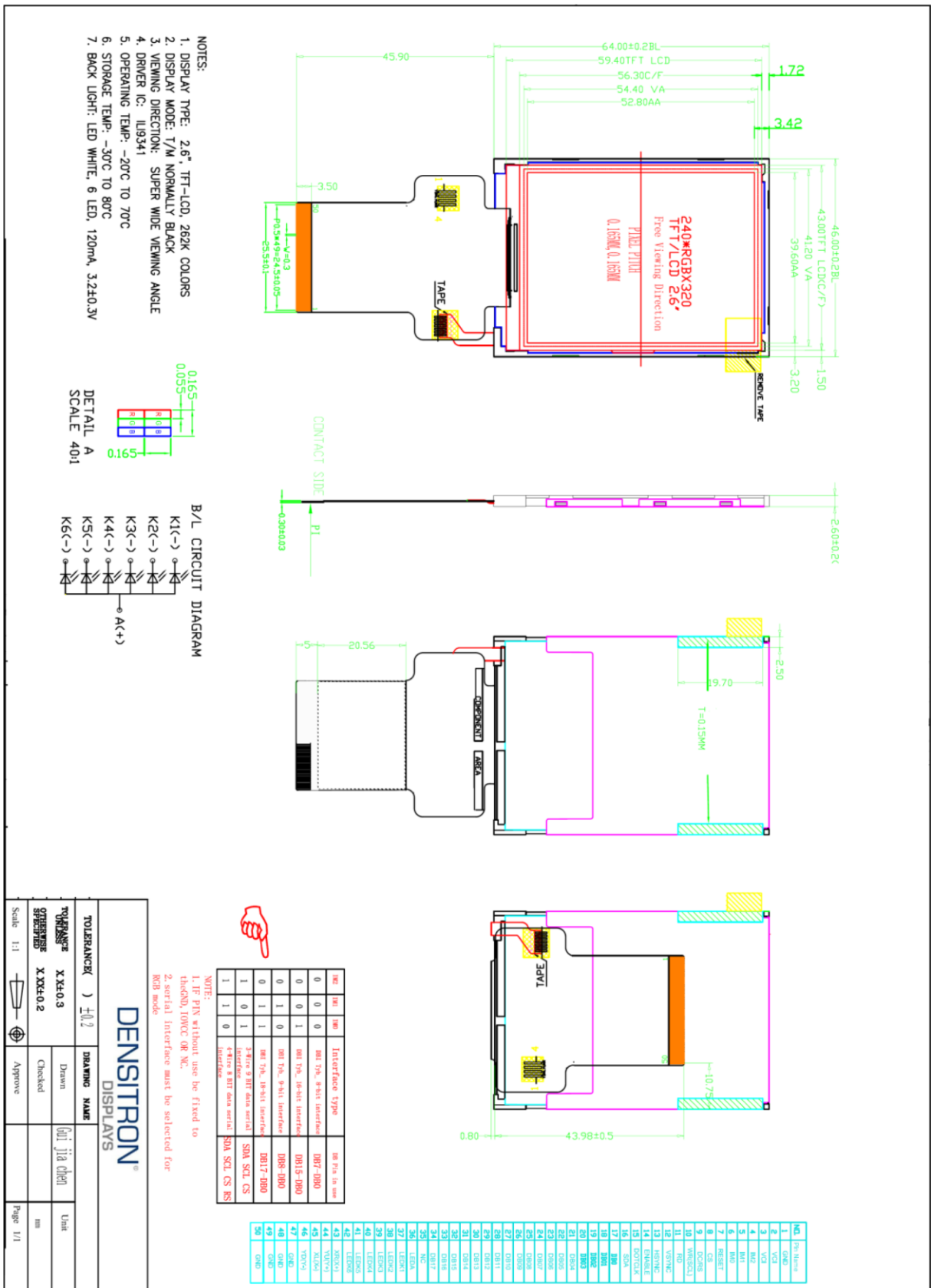

### 3 ELECTRICAL SPECIFICATION

#### 3.1 ABSOLUTE MAXIMUM RATINGS

---

Item	Symbol	Condition	Min	Max	Unit	Note
Power Supply Voltage	VCI	Ta=25°C	-0.3	4.6	V	
Operating Temperature	TOP		-20	70	°C	1
Storage Temperature	TST		-30	80	°C	1,2,3

Note 1. 90 % RH Max for Ta<50 °C, and 60% RH for Ta≥50°C.

Note 2. In case of below 0°C, the response time of liquid crystal (LC) becomes slower and the colour of panel becomes darker than normal one. Level of retardation depends on temperature, because of LC's characteristic.

Note 3. Only operation is guaranteed at operating temperature. Contrast, response time, another display quality are evaluated at +25°C.

#### 3.2 ELECTRICAL CHARACTERISTICS

---

Item	Symbol	Condition	Min	Typ	Max	Unit	Note
Supply Voltage	VCI		2.5	2.8	3.3	V	
Input Voltage for Logic	V <sub>IH</sub>		0.8V <sub>DDIO</sub>	-	-	V	
	V <sub>IL</sub>		-	-	0.2 V <sub>DDIO</sub>	V	
Output Voltage for Logic	V <sub>OH</sub>		0.8 V <sub>DDIO</sub>	-	-	V	
	V <sub>OL</sub>		-	-	0.2 V <sub>DDIO</sub>	V	
Current Consumption	V <sub>CCI</sub>		-	10		mA	1

Note 1: The specified power consumption is under the conditions of VCI=2.8V, FV=60Hz.

### 3.3 INTERFACE PIN ASSIGNMENT

NO.	SYMBOL	Description					
1	GND	Ground.					
2	VCI	Power supply voltage (VCI=2.5V-3.3V).					
3	VCI						
4	IM2	IM2	IM1	IM0	MCU-Interface Mode	DB Pin in use	
						Register/Content	GRAM
		0	0	0	80 MCU 8-bit bus interface I	D[7:0]	D[7:0]
		0	0	1	80 MCU 16-bit bus interface I	D[7:0]	D[15:0]
5	M1	0	1	0	80 MCU 9-bit bus interface I	D[7:0]	D[8:0]
		0	1	1	80 MCU 18-bit bus interface I	D[7:0]	D[17:0]
6	IM0	1	0	1	3-wire 9-bit data serial interface I	SDA: In/OUT	
		1	1	0	4-wire 8-bit data serial interface I	SDA: In/OUT	
7	RESET(RESX)	This signal low will reset the device and must be applied to properly initialize the chip. Signal is low active.					
8	CSX	System bus select signal. Low: Select (Accessible) High: Not select (Inaccessible)					
9	D/CX	Display data / Command selection pin. RS='1': Display data. RS='0': Command data.					
10	WRX	8080-I/8080-II system (WRX): serves as a read signal and MCU read data at the rising edge.					
11	RDX	Read strobe signal. Data are read when RDX is low.					
		If not used, please connect this pin to VCI.					
12	VSYNC	Frame synchronizing signal for RGB interface operation. Fix to VDDI or VSS level when not in use.					
13	HSYNC	Line synchronous signal for RGB interface operation. Fix to VDDI or VSS level when not in use.					
14	ENABLE	Data enable signal for RGB interface operation. Fix to VDDI or VSS level when not in use.					
15	DOTCLK	Dot clock signal for RGB interface operation. Fix to VDDI or VSS level when not in use.					
16	SDA	Serial data input/output pin. The data is applied on the rising edge of the SCL signal.					
17-34	DB0-DB17	Data bus. Connect to GND when is not used.					
35	SDO	Serial output signal. The data is outputted on the falling edge of the SCL signal. If not used, open this pin.					



<b>NO.</b>	<b>SYMBOL</b>	<b>Description</b>
<b>36</b>	LEDA	LED Anode.
<b>37</b>	LEDK1	LED Cathode1.
<b>38</b>	LEDK2	LED Cathode2.
<b>39</b>	LEDK3	LED Cathode3.
<b>40</b>	LEDK4	LED Cathode4.
<b>41</b>	LEDK5	LED Cathode5.
<b>42</b>	LEDK6	LED Cathode6
<b>43</b>	XR(NC)	(Touch panel Right Glass Terminal)
<b>44</b>	YU(NC)	(Touch panel Top Terminal)
<b>45</b>	XL(NC)	(Touch panel Left Film Terminal)
<b>46</b>	YD(NC)	(Touch panel Bottom Film Terminal)
<b>47-50</b>	GND	Ground

### 3.4 TIMING CHARACTERISTICS

Please refer to Ilitech IC ILI9341 datasheet for more information

#### 3.4.1 80 MCU-Interface I (18/16/9/8 Bits) Timing Characteristics

Item	Symbol	MIN	MAX	Unit	Remark
Address setup time	RS(DCX)	tast	0	-	ns
Address hold time (Write/Read)		taht	0	-	ns
Chip select setup time (write)	CS(CSX)	tcs	15	-	ns
Chip select setup time (Read ID)		trcs	45	-	ns
Chip select setup time (Read FM)		trcsfm	355	-	ns
Chip select Wait time (Write/Read)		tcsf	10	-	ns
Write cycle Time	WR(WRX)	twc	66	-	ns
Write Control pulse H duration		twrh	15	-	ns
Write Control pulse L duration		twrl	15	-	ns
Read cycle (FM)	RD(RDX (FM))	trcfm	450	-	ns
Read Control H duration (FM)		trdhfm	90	-	ns
Read Control L duration (FM)		trdlfm	355	-	ns
Read cycle (ID)	RD(RDX (ID))	trcs	160	-	ns
Read Control H duration		trdh	90	-	ns
Read Control L duration		trdl	45	-	ns
Write data setup time	D[17:0], D[15:0], D[8:0], D[7:0]	tdst	10	-	ns
Write data hold time		tdht	10	-	ns
Read access time		trat	-	40	ns
Read access time (FM)		tratfm	-	340	ns
Read output disable time		trod	20	80	ns

Note: Ta=-30 to 70°C, VDDI=1.65V to 3.3V, VCI=2.5V to 3.3V, VSS=0V

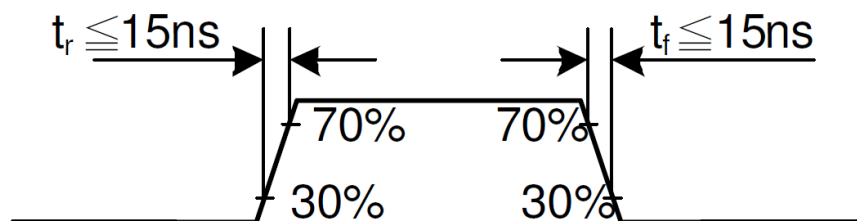

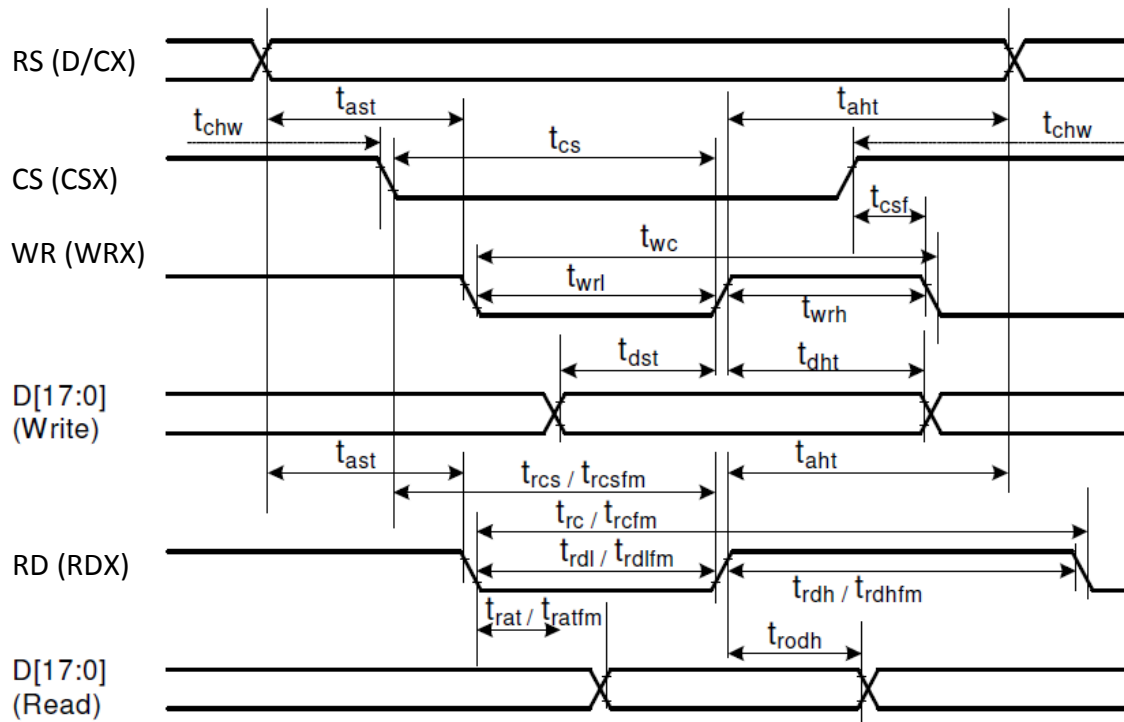

### 3.4.2 16/18-bit Parallel RGB Timing Characteristics

Item	Symbol	MIN	MAX	Unit	
VSYNC / HSYNC setup time	VSYNC / HSYNC	tSYNCS	15	-	ns
VSYNC / HSYNC hold time		tSYNCH	15	-	ns
DE setup time	DE	tENS	15	-	ns
DE hold time		tENH	15	-	ns
Data setup time	D[17:0]	tPOS	15	-	ns
Data hold time		tpDH	15	-	ns
DOTCLK high-level pulse period	DOTCLK	PWDH	15	-	ns
DOTCLK low-level pulse period		PWDL	15	-	ns
DOTCLK cycle time		tCYCD	100	-	ns
DOTCLK, HSYNC, VSYNC rise/fall time		trgbr, trgbf	-	15	ns

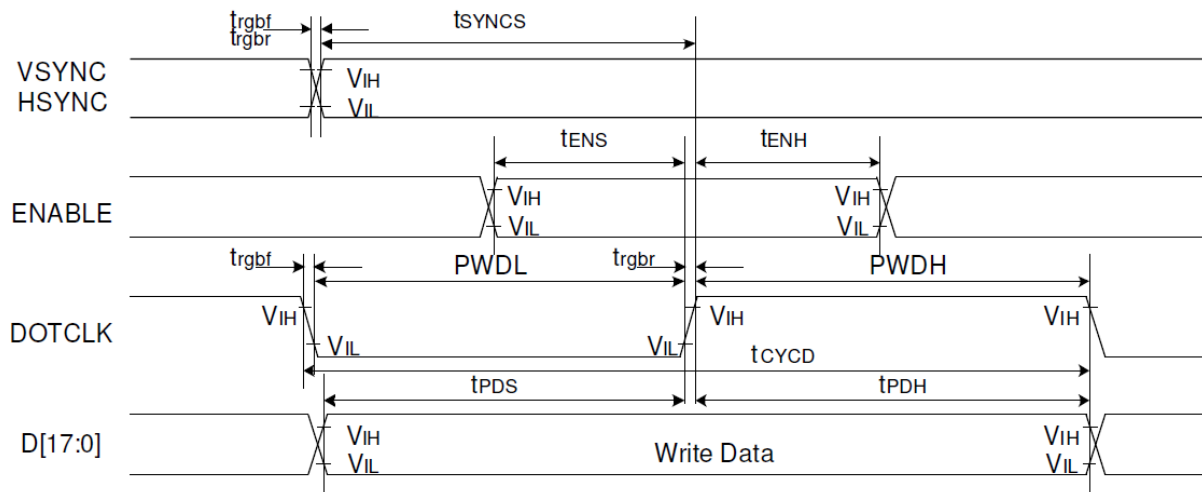
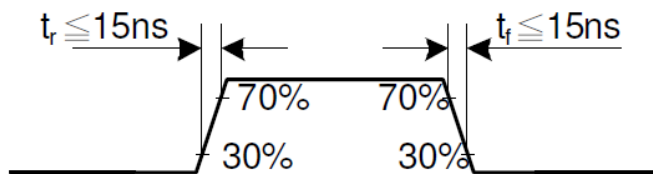

### 3.4.3 Serial Interface Timing Characteristics (3-wire SPI)

Item	Symbol	MIN	MAX	Unit	
Serial Clock Cycle (Write)	SCL	tscycw	100	-	ns
SCL "H" Pulse Width (Write)		tshw	40	-	ns
SCL "L" Pulse Width (Write)		tslw	40	-	ns
Serial Clock Cycle (Read)		tscycr	150	-	ns
SCL "H" Pulse Width (Read)		tshr	60	-	ns
SCL "L" Pulse Width (Read)		tslr	60	-	ns
Data setup time (Write)	SDA / SDI (Input)	tsds	30	-	ns
Data hold time (Write)		tsdh	30	-	ns
Access time (Read)	SDA / SDO (Output)	tacc	10	-	ns
Output disable time (Read)		toh	10	50	ns
SCL-CS(CSX)	CSX (CS)	tsc	20	-	ns
CS(CSX) "H" Pulse Width		tch	40	-	ns
CS(CSX)-SCL Time		tcss	60	-	ns
		tcs	65	-	ns

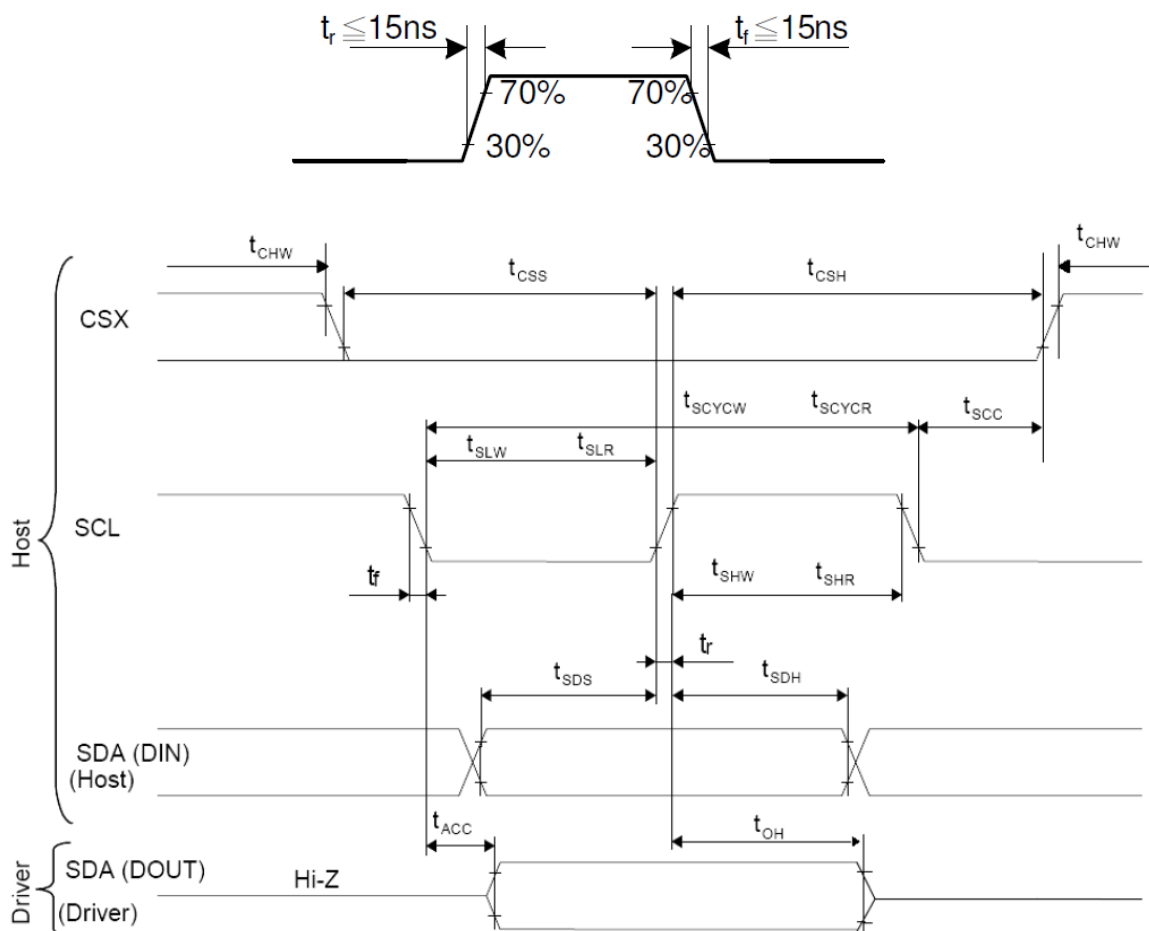

### 3.4.4 Serial Interface Timing Characteristics (4-wire SPI)

Item	Symbol	MIN	MAX	Unit	
Serial Clock Cycle (Write)	SCL	t <sub>wc</sub>	100	-	ns
SCL "H" Pulse Width (Write)		t <sub>wrh</sub>	40	-	ns
SCL "L" Pulse Width (Write)		t <sub>wrl</sub>	40	-	ns
Serial Clock Cycle (Read)		t <sub>rc</sub>	150	-	ns
SCL "H" Pulse Width (Read)		t <sub>rdh</sub>	60	-	ns
SCL "L" Pulse Width (Read)		t <sub>rdl</sub>	60	-	ns
D/CX setup time	D/CX	t <sub>as</sub>	10	-	
D/CX hold time (write/read)		t <sub>ah</sub>	10	-	
Data setup time (Write)	SDA / SDI (Input)	t <sub>ds</sub>	30	-	ns
Data hold time (Write)		T <sub>dh</sub>	30	-	ns
Access time (Read)	SDA / SDO (Output) *Note1	t <sub>acc</sub>	10	-	ns
Output disable time (Read)		t <sub>od</sub>	10	50	ns
Chip select time (write)	CSX (CS)	t <sub>scc</sub>	40	-	ns
Chip select hold time (Read)		t <sub>csh</sub>	40	-	ns

Note1: For maximum CL=30pF , For minimum CL=8pF

Ta=-25°C, VDDI=1.65V to 3.3V, VCI=2.5V to 3.3V, AGND=VSS=0V

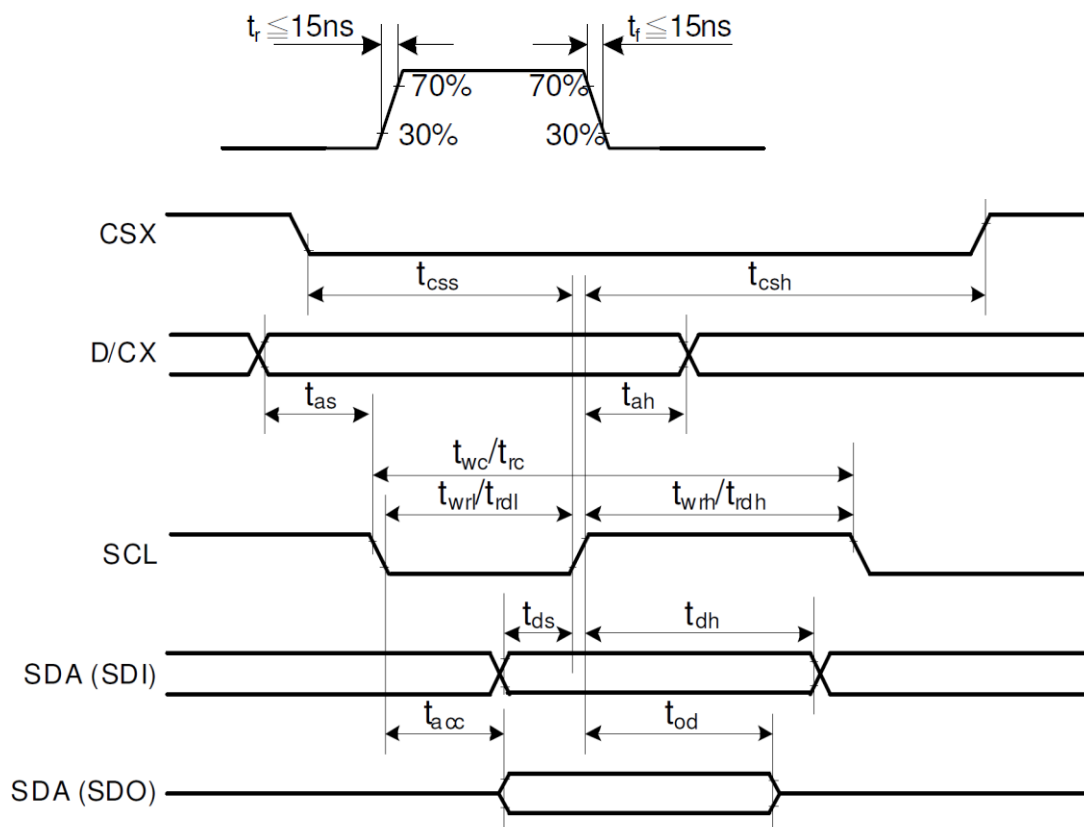

### 3.5 COMMAND TABLE

Operational Code (HEX)	Function	Read/Write / Command	Number of Parameter	Parameters
00	No Operation	C	0	-
01	Software Reset	C	0	-
04	Read Display Identification Information	R	3	
09	Read Display Status	R	4	
0A	Read Display Power Mode	R	1	
0B	Read display MADCTL	R	1	
0C	Read Display Pixel Format	R	1	
0D	Read Display Image Mode	R	1	
0E	Read Display Signal Mode	R	1	
0F	Read Display Self Diagnostic Result	R	1	
10	Sleep In	C	0	-
11	Sleep Out	C	0	-
12	Partial Mode On	C	0	-
13	Normal Display Mode On	C	0	-
20	Display Inversion Off	C	0	-
21	Display Inversion On	C	0	-
26	Gamma Set	W	1	format: 1byte for curve selection
28	Display Off	C	0	-
29	Display On	C	0	-
2A	Column Address Set	W	4	format: 2 byte for leftmost Column counter 2 byte for rightmost Column counter
2B	Page Address Set	W	4	format: 2 byte for top line pointer 2 byte for bottom line pointer
2C	Memory Write	W	Any length	Successive video data stream Format in all colour modes
2E	Memory Read	R	Any length	Successive video data stream Format in all colour modes
30	Partial Area	W	4	format: 2 byte for top line pointer 2 byte for bottom line pointer

Operational Code (HEX)	Function	Read/Write / Command	Number of Parameter	Parameters
33	Vertical Scrolling Definition	W	6	format: 2 byte for fixed area top line pointer 2 byte for scrolling area height 2 byte for fixed area bottom line pointer
34	Tearing Effect Line Off	C	0	
35	Tearing Effect Line On	W	1	1 byte for Tearing Effect Line Mode selection
36	Memory Data Access Control	W	1	1 byte for memory scan direction
37	Vertical Scrolling Start Address	W	2	2 byte for line pointer
38	Idle Mode Off	C	0	-
39	Idle Mode On	C	0	-
3A	Interface Pixel Format	W	1	Refer to ILI9341 datasheet
DA	Read ID1	R	(1)	
DB	Read ID2	R	(1)	
DC	Read ID3	R	(1)	



### 3.6 POWER SEQUENCE

VCI can be applied in any order.

VCI can be powered down in any order.

During power off, if LCD is in the Sleep Out mode, VCI must be powered down minimum 120msec after RESET has been released.

During power off, if LCD is in the Sleep In mode, VCI can be powered down minimum 0msec after RESET has been released.

CS can be applied at any timing or can be permanently grounded. RESET has priority over CS.

Note 1: There will be no damage to the display module if the power sequences are not met.

Note 2: There will be no abnormal visible effects on the display panel during the Power On/Off Sequences.

Note 3: There will be no abnormal visible effects on the display between end of Power On Sequence and before receiving Sleep Out command. Also between receiving Sleep In command and Power Off Sequence.

Note 4: If RESET line is not held stable by host during Power On Sequence as defined in Sections 3.7.1 and 3.7.2, then it will be necessary to apply a Hardware Reset (RESET) after Host Power On Sequence is complete to ensure correct operation. Otherwise function is not guaranteed.

#### 3.6.1 Case 1 – RESET line is held High or Unstable by Host at Power ON

If RESET (RESX) line is held High or unstable by the host during Power On, then a Hardware Reset must be applied after VCI has been applied – otherwise correct functionality is not guaranteed. There is no timing restriction upon this hardware reset.

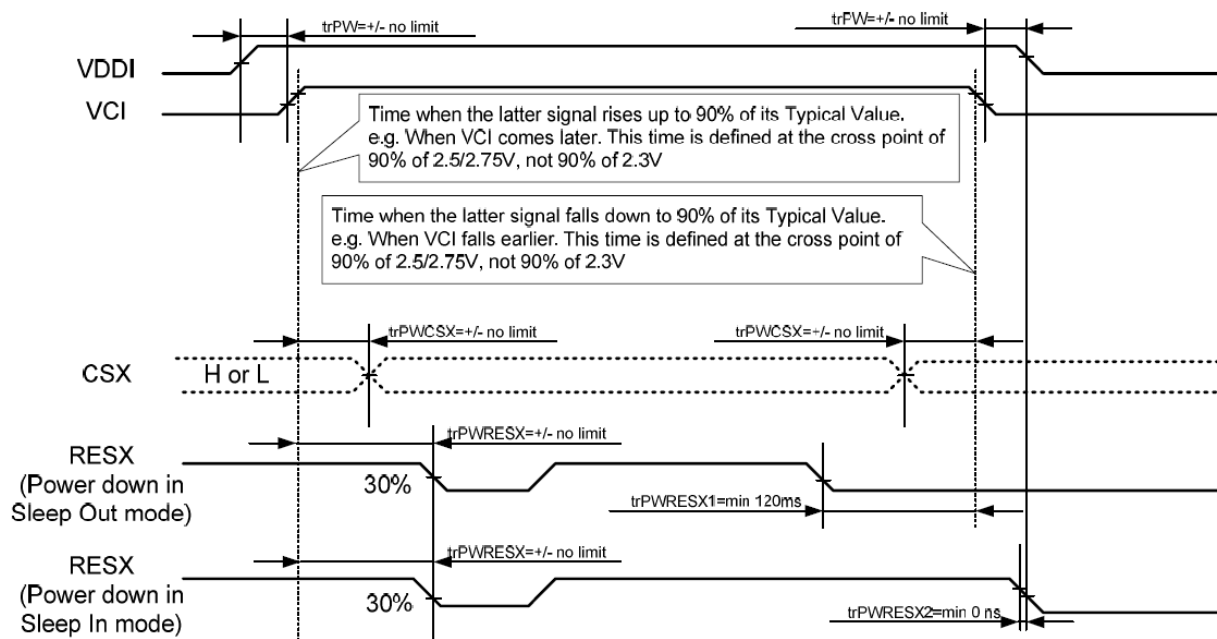

$trPWRESX1$  is applied to RESET (RESX) falling in the Sleep Out Mode

$trPWRESX2$  is applied to RESET (RESX) falling in the Sleep In Mode

### 3.6.2 Case 2 – RESET line is held Low by Host at Power ON

If RESET (RESX) line is held Low (and stable) by the host during Power On, then the RESET must be held low for minimum 10µsec after VCI has been applied.

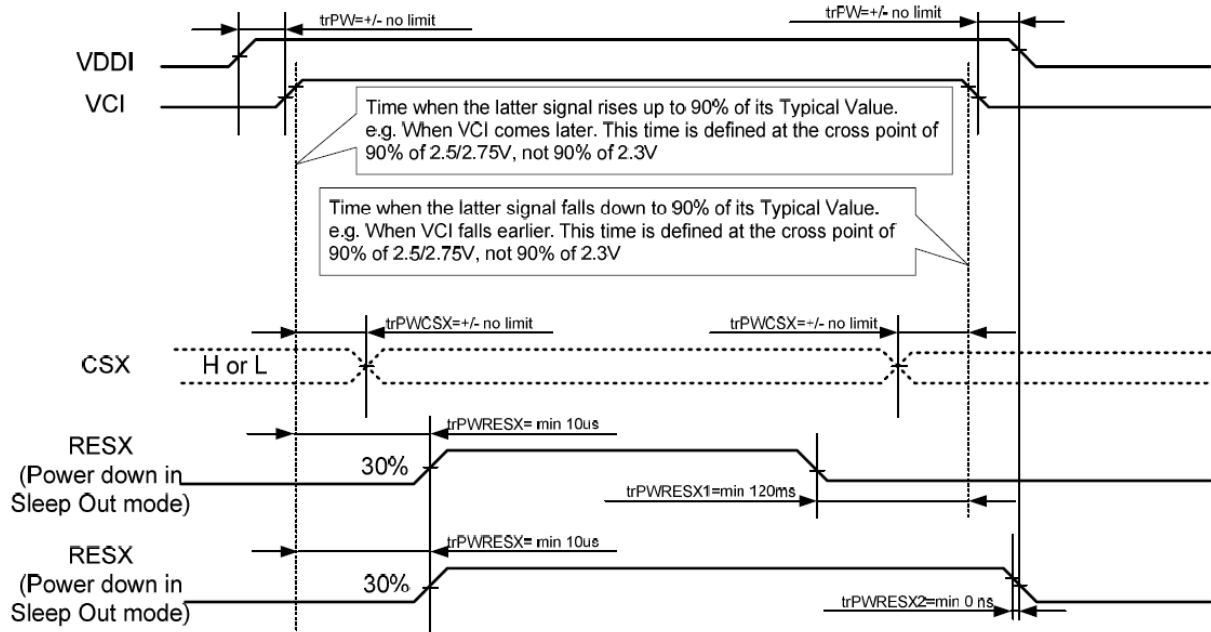

$trPWRESX1$  is applied to RESET (RESX) falling in the Sleep Out Mode

$trPWRESX2$  is applied to RESET (RESX) falling in the Sleep In Mode

### 3.6.3 Uncontrolled Power Off

The uncontrolled power off means a situation when e.g. there is removed a battery without the controlled power off sequence. There will not be any damages for the display module or the display module will not cause any damages for the host or lines of the interface. At an uncontrolled power off event, ILI9341 will force the display to blank and will not be any abnormal visible effects within 1 second on the display and remains blank until "Power On Sequence" activates.

For other settings and details please refer to ILI9341 data sheet.

## 4 OPTICAL SPECIFICATION

### 4.1 OPTICAL CHARACTERISTICS

Measuring instruments: LCD-5100, Eldim, Topcon BM-7  
 Driving condition: VCI = 2.8V, VSS = 0V  
 Backlight: IF=20mA  
 Measured temperature: Ta = 25° C

Item		Symbol	Condition	MIN	TYP	MAX	Unit	Note
Response Time		TR+TF	$\theta=\phi=0^\circ$ Normal Viewing Angle	-	35	50	ms	2
Contrast Ratio		CR		400	500	-		3
Viewing Angle	Left	$\theta_L$	CR $\geq$ 10	-	80	-	deg	4
	Right	$\theta_R$		-	80	-	deg	
	Up	$\phi_U$		-	80	-	deg	
	Down	$\phi_D$		-	80	-	deg	
Colour Chromaticity	Red	Rx	CR $\geq$ 10	0.640	0.660	0.680	-	5
		Ry		0.297	0.317	0.337	-	
	Green	Gx		0.240	0.260	0.280	-	
		Gy		0.555	0.575	0.595	-	
	Blue	Bx		0.121	0.141	0.161	-	
		By		0.055	0.075	0.095	-	
	White	Wx		0.275	0.295	0.315	-	
		Wy		0.297	0.317	0.337	-	
Centre Brightness				-	500	-	cd/m <sup>2</sup>	6
Brightness Distribution				80	-	-	%	7

### 4.1.1 Test Method

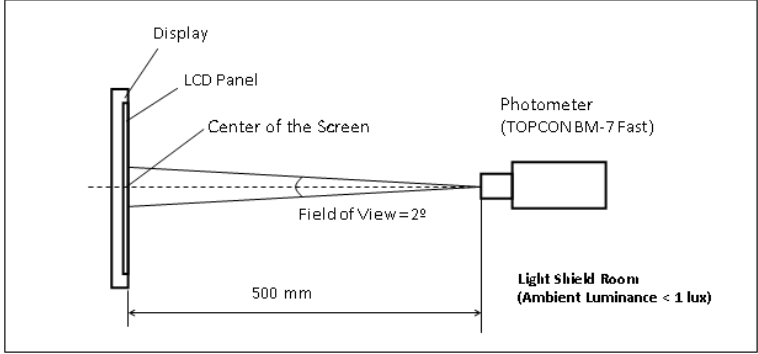
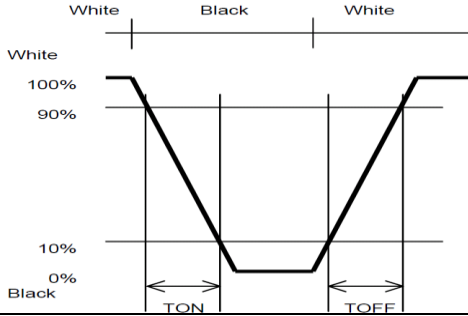
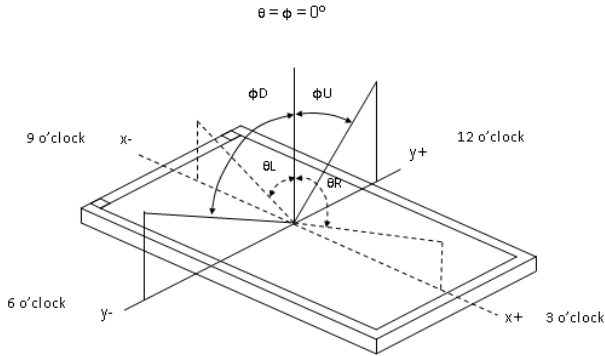
Note	Item	Test method
1	Setup	<p>The display should be stabilised at a given temperature for 30 minutes to avoid abrupt temperature change during measuring. In order to stabilise the luminance, measurements should be executed after lighting the backlight for 30 minutes in a windless room.</p> 
2	Response time	<p>Measure output signal waveform by the luminance meter when raster of window pattern is changed from white to black and from black to white.</p> 
3	Contrast ratio	<p>Measure maximum brightness and minimum brightness at the centre of the screen by displaying raster or window pattern. Then calculate the ratio between these two values.</p> $\text{Contrast Ratio (CR)} = \frac{\text{Brightness of unselected position (white)}}{\text{Brightness of selected position (black)}}$
4	Viewing angle Horizontal $\theta$ Vertical $\phi$	<p>Move the luminance meter from right to left and up and down and determinate the angles where contrast ratio is 10</p> 
5	Colour chromaticity	Measure chromaticity coordinates x and y of CIE1931 colorimetric system
6	Centre brightness	Measure the brightness at the centre of the screen
7	Brightness distribution	<p>(Brightness distribution)= <math>100 \times B/A \%</math>  A: max. brightness of the 9 points  B: min. brightness of the 9 points</p>

## 5 BACKLIGHT SPECIFICATION

### 5.1 LED DRIVING CONDITIONS

---

Item	Symbol	Condition	Min	Typ	Max	Unit
Forward Current	IF	Ta=25 °C, VF=3.2V/LED	-	120	-	mA
Forward Voltage	VF	Ta= 25°C, IF= 20mA/LED		3.2		V

**Note:**

- The lifetime of the LED is defined as a period till the brightness of the LED decreases to the half of its initial value.
- This figure is given as a reference purpose only, and not a guarantee.
- This figure is estimated for an LED operating alone.  
The performance of an LED may differ when assembled as a monitor together with a TFT panel due to different environmental temperature.
- Estimated lifetime could vary on a different temperature and usually higher temperature could reduce the life significantly.

## 6 QUALITY ASSURANCE SPECIFICATION

### 6.1 DELIVERY INSPECTION STANDARDS

#### 6.1.1 Inspection Conditions

Inspection distance: 30 cm ± 2 cm  
Viewing angle: ±45°

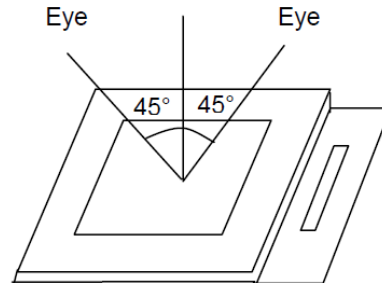

#### 6.1.2 Environmental Conditions

Ambient temperature: 23°C ±5°C  
Ambient humidity: 55±10% RH  
Ambient illumination: 1000~1500 lux

#### 6.1.3 Sampling Conditions

1. Lot size: quantity of shipment lot per model
2. Sampling method:

Sampling Plan		ANSI / ASQC Z1.4-1993
		Normal inspection, Single Sampling
AQL	Major Defect	0.65%
	Minor Defect	1.5%

#### 6.1.4 Definition of Area

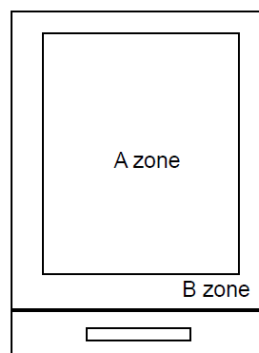

A zone: active area  
B zone: viewing area



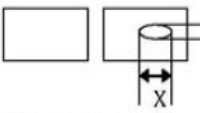
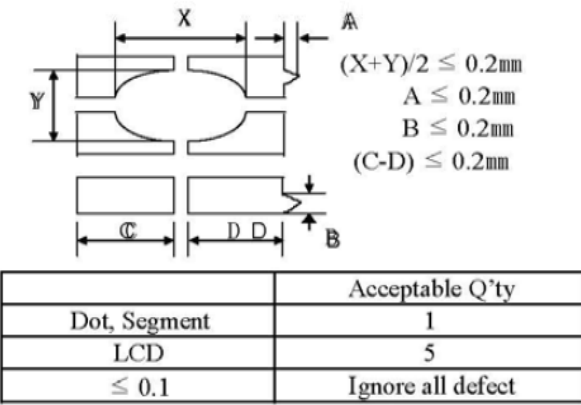
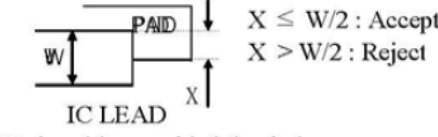

#### 6.1.5 Basic Principle

A set of sample to indicate the limit of acceptable quality level shall be discussed should a dispute occur.

### 6.1.6 Inspection Criteria

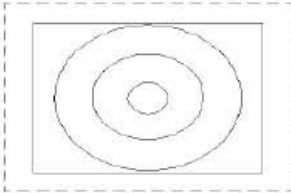
No	Item	Criteria	Rank	Remark								
8	Pin hole (On Segment)	 <p> <math>(X+Y)/2 \leq 0.2\text{mm}</math>                      Within 1 per one segment (Less than 0.1mm is not counted)                      Total defects q'ty is must not exceed 5 pieces.                 </p>	MI									
9	Segment Deformation	 <p> <math>(X+Y)/2 \leq 0.2\text{mm}</math>  <math>A \leq 0.2\text{mm}</math>  <math>B \leq 0.2\text{mm}</math>  <math>(C-D) \leq 0.2\text{mm}</math> </p> <table border="1" data-bbox="550 851 1133 985"> <thead> <tr> <th></th> <th>Acceptable Q'ty</th> </tr> </thead> <tbody> <tr> <td>Dot, Segment</td> <td>1</td> </tr> <tr> <td>LCD</td> <td>5</td> </tr> <tr> <td><math>\leq 0.1</math></td> <td>Ignore all defect</td> </tr> </tbody> </table> <p>Each visible dot must be more than half effective dot area</p>		Acceptable Q'ty	Dot, Segment	1	LCD	5	$\leq 0.1$	Ignore all defect	MI	$(X + Y)/2 \leq 0.2\text{mm}$
	Acceptable Q'ty											
Dot, Segment	1											
LCD	5											
$\leq 0.1$	Ignore all defect											
10	Color Variation	Within the three colors, except LCD Standard color is acceptable.	MI									
11	Glass & Polarizer Scratch	Follow NO.5(2) condition	MI									
12	Solder Ball	1)Acceptable if the size of void is less than 0.18mm 2)Acceptable if a solder ball is not movable 3)Rejectable if the solder ball exceed 5EA in $2.54 \times 2.54\text{mm}$ area.	MI									
13	Miss Alignment	1)Acceptable if it dose not exceed 50% of the lead width IC.  <p> <math>X \leq W/2</math> : Accept  <math>X &gt; W/2</math> : Reject                 </p> 2)Rejectable, provided that it does exceed 50% of the component termination width.  <p> <math>W1 &gt; W2</math> : Reject                 </p>										

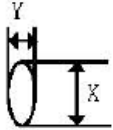
No	Item	Criteria	Rank	Remark																																																
14	Touch Panel	<p>1) Round Type、 Foreign Substances</p> <table border="1"> <thead> <tr> <th rowspan="2">Area Dimension**</th> <th colspan="2">Acceptable Q'ty</th> <th rowspan="2">Remark</th> </tr> <tr> <th>A Area</th> <th>B Area</th> </tr> </thead> <tbody> <tr> <td>≤ 0.1</td> <td colspan="2">Ignore</td> <td rowspan="4"></td> </tr> <tr> <td>≤ 0.2</td> <td>2</td> <td>Ignore</td> </tr> <tr> <td>≤ 0.3</td> <td>1</td> <td>Ignore</td> </tr> <tr> <td>0.3 &lt;</td> <td>0</td> <td>Ignore</td> </tr> </tbody> </table> <p>2) Liner Type &amp; Scratch</p> <table border="1"> <thead> <tr> <th colspan="2">Dimension</th> <th colspan="2">Acceptable Q'ty</th> <th rowspan="2">Remark</th> </tr> <tr> <th>Length</th> <th>Width</th> <th>A Area</th> <th>B Area</th> </tr> </thead> <tbody> <tr> <td>-</td> <td>W ≤ 0.025</td> <td colspan="2">Ignore</td> <td rowspan="5">Ignore</td> </tr> <tr> <td>L ≤ 3.0</td> <td rowspan="2">W ≤ 0.05</td> <td colspan="2">Ignore</td> </tr> <tr> <td>3.0 &lt; L ≤ 5.0</td> <td colspan="2">2</td> </tr> <tr> <td>≤ 7</td> <td>W ≤ 0.1</td> <td colspan="2">1</td> </tr> <tr> <td>-</td> <td>W &gt; 0.1</td> <td colspan="2">Follow round type</td> </tr> </tbody> </table> <p>4) Newton Ring</p> <p>a) Regular</p>  <p>The area of the Newton ring is more than 1/3 area of the touch panel It's NG. The area of the Newton ring is less than 1/3 area of the touch panel It's OK.</p> <p>b) None-regularity</p>  <p>The area of the Newton ring is more than 1/2 area of the touch panel It's NG. The area of the Newton ring is less than 1/2 area of the touch panel It's OK.</p>	Area Dimension**	Acceptable Q'ty		Remark	A Area	B Area	≤ 0.1	Ignore			≤ 0.2	2	Ignore	≤ 0.3	1	Ignore	0.3 <	0	Ignore	Dimension		Acceptable Q'ty		Remark	Length	Width	A Area	B Area	-	W ≤ 0.025	Ignore		Ignore	L ≤ 3.0	W ≤ 0.05	Ignore		3.0 < L ≤ 5.0	2		≤ 7	W ≤ 0.1	1		-	W > 0.1	Follow round type		MI	 <p>** : Mean Diameter (X + Y)/2</p>
Area Dimension**	Acceptable Q'ty			Remark																																																
	A Area	B Area																																																		
≤ 0.1	Ignore																																																			
≤ 0.2	2	Ignore																																																		
≤ 0.3	1	Ignore																																																		
0.3 <	0	Ignore																																																		
Dimension		Acceptable Q'ty		Remark																																																
Length	Width	A Area	B Area																																																	
-	W ≤ 0.025	Ignore		Ignore																																																
L ≤ 3.0	W ≤ 0.05	Ignore																																																		
3.0 < L ≤ 5.0		2																																																		
≤ 7	W ≤ 0.1	1																																																		
-	W > 0.1	Follow round type																																																		



### **6.1.7 Classification of Defects**

Visual defects (except no or wrong label) are treated as minor defects, while electrical defects are treated as major defects.

Two minor defects are equal to one major defect in lot sampling inspection.

### **6.1.8 Identification / marking criteria**

Any unit with illegible / wrong / double or no marking / label shall be rejected.

## ***6.2 DEALING WITH CUSTOMER COMPLAINTS***

---

### **6.2.1 Non-conforming analysis**

Purchaser should supply Densitron with detailed data of non-conforming sample.

After accepting it, Densitron should complete the analysis in two weeks from receiving the sample.

If the analysis cannot be completed on time, Densitron must inform the purchaser.

### **6.2.2 Handling of non-conforming displays**

If any non-conforming displays are found during customer acceptance inspection which Densitron is clearly responsible for, return them to Densitron.

Both Densitron and customer should analyse the reason and discuss the handling of non-conforming displays when the reason is not clear.

Equally, both sides should discuss and come to agreement for issues pertaining to modification of Densitron quality assurance standard.

## 7 RELIABILITY SPECIFICATION

### 7.1 RELIABILITY TESTS

Test Item		Test Condition
Durability Test	High Temperature Storage	Ta= 80°C 96h
	Low Temperature Storage	Ta=-30°C 96h
	Temperature Cycle Storage	-20°C for 30 min, then 70°C for 30 min, 20 cycles
	High Temperature Operation	Tp= 70°C 96h
	Low Temperature Operation	Tp= -20°C 96h
	High Temperature & Humidity Operation	Tp= 40°C RH= 90% 96h Non condensing
	Thermal Shock Resistance	The sample should be allowed to stand the following 5 cycles of operation: TSTL for 30 minutes -> normal temperature for 5 minutes -> TSTH for 30 minutes -> normal temperature for 5 minutes, as one cycle, then taking it out and drying it at normal temperature, and allowing it stand for 24 hours
	Box Drop Test	1 Corner 3 Edges 6 faces, 66 cm (MEDIUM BOX)

Note: Ta=ambient temperature Tp= Panel temperature

No time over 10 seconds, OFF time under 10 seconds.

Notes:

1. No dew condensation to be observed.
2. The function test shall be conducted after 4 hours storage at the normal temperature and humidity after removed from the test chamber.
3. No cosmetic or functional defects should be allowed.
4. Total current consumption should be less than twice the initial value.

## 8 HANDLING PRECAUTIONS

### **Safety**

If the LCD panel breaks, be careful not to get the liquid crystal fluid in your mouth or in your eyes. If the liquid crystal touches your skin or clothes, wash it off immediately using soap and plenty of water.

### **Mounting and Design**

Place a transparent plate (e.g. acrylic, polycarbonate or glass) on the display surface to protect the display from external pressure. Leave a small gap between the transparent plate and the display surface.

When assembling with a zebra connector, clean the surface of the pads with alcohol and keep the surrounding air very clean.

Design the system so that no input signal is given unless the power supply voltage is applied.

### **Caution during LCD cleaning**

Lightly wipe the display surface with a soft cloth soaked with Isopropyl alcohol, Ethyl alcohol or Trichlorotrifluoroethane.

Do not wipe the display surface with dry or hard materials that will damage the polariser surface.

Do not use aromatic solvents (toluene and xylene), or ketonic solvents (ketone and acetone).

### **Caution against static charge**

As the display uses C-MOS LSI drivers, connect any unused input terminal to VDD or VSS. Do not input any signals before power is turned on. Also, ground your body, work/assembly table and assembly equipment to protect against static electricity.

### **Packaging**

Displays use LCD elements, and must be treated as such. Avoid strong shock and drop from a height. To prevent displays from degradation, do not operate or store them exposed directly to sunshine or high temperature/humidity.

### **Caution during operation**

It is indispensable to drive the display within the specified voltage limit since excessive voltage shortens its life. Direct current causes an electrochemical reaction with remarkable deterioration of the display quality. Give careful consideration to prevent direct current during ON/OFF timing and during operation. Response time is extremely delayed at temperatures lower than the operating temperature range while, at high temperatures, displays become dark. However, this phenomenon is reversible and does not mean a malfunction or a display that has been permanently damaged. If the display area is pushed on hard during operation, some graphics will be abnormally displayed but returns to a normal condition after turning off the display once. Even a small amount of condensation on the contact pads (terminals) can cause an electro-chemical reaction which causes missing rows and columns. Give careful attention to avoid condensation.

### **Storage**

Store the display in a dark place where the temperature is 25°C ± 10°C and the humidity below 50%RH. Store the display in a clean environment, free from dust, organic solvents and corrosive gases.

Do not crash, shake or jolt the display (including accessories).

Product No.	DET026QVNMNT0S-1A	REV. 1.0
-------------	-------------------	----------

Page	27 / 27
------	---------