

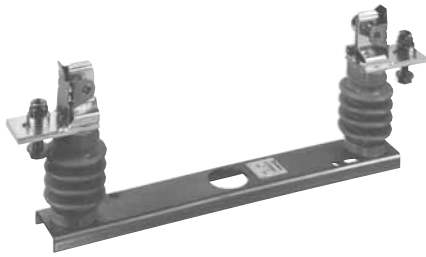

Semiconductor Fuses AC+DC Square-boby Fuse Bases Bases for DC other Blades Fuses - Size 300 & 602: SPV

FUSE HOLDERS FOR BLADE-TYPE CV3 FUSES



- STURDY ASSEMBLY WITH VERY HIGH COLLISION AND TEMPERATURE WITHSTAND
- MOUNTING AS BASES
- FIBER-GLASS POLYESTER OR CERAMIC INSULATORS FOR BASIC APPLICATIONS, IN CORROSIVE ATMOSPHERES OR IN TRACTION
- VERY HIGH COLLISION WITHSTAND FOR TRACTION
- INTERLOCKING OF REPLACEMENT PART
- COMPLYING WITH IEC 77 STANDARD

Main Characteristics

Designation	Catalog Number	Insulation voltage (V) Ui (AC 50/60 Hz & DC)	Current (A)	Dielectric withstand test (kV)		Fire and fumes class
				RMS voltage 1 mn 50/60 Hz	Impulse voltage 1.2/50µs	
SPV 300		7 200	180	20	40	UL 94 VO
SPV 600		7 200	180	20	40	Ceramic insulator

No use limitation for FERRAZ SHAWMUT fuses mounted in the above holders.

Vibration withstand:

Tests with sine vibrations carried out at ambient with scanning each of the three main holder axes.

Spectrum: 1st segment (2 to 16 Hz) constant displacement $x = 5 \text{ mm peak}$.

2nd segment (16 to 250 Hz) constant acceleration $\gamma = 5 \text{ g peak}$.

Exponential scanning speed: 1 octave per minute.

Duration: 2 hours per axis.



Semiconductor Fuses

AC+DC Square-boby Fuse Bases

Bases for DC other Blades Fuses - Size 300 & 602: SPV

FUSE HOLDERS FOR BLADE-TYPE CV3 FUSES

SPV 300

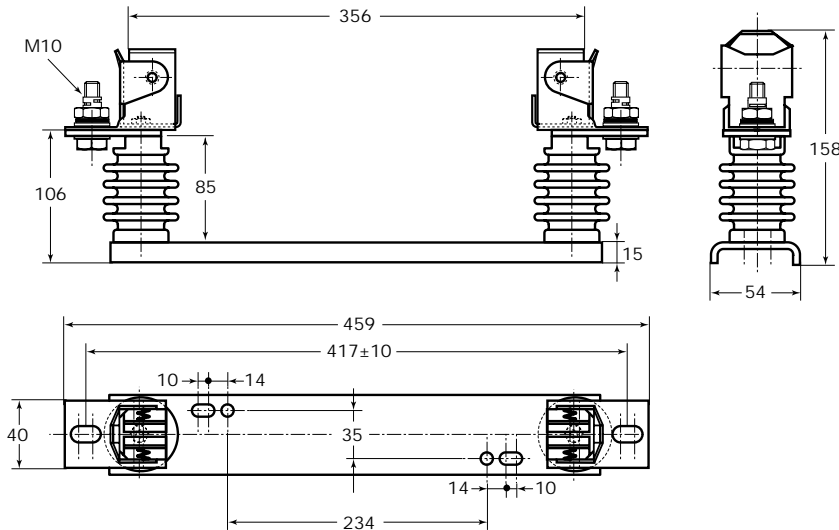

Designation	Ref. Number	Cat. Number	Weight (g)	Packaging
SPV 300	W 098965	SPV300	1 830	1

SPV 600

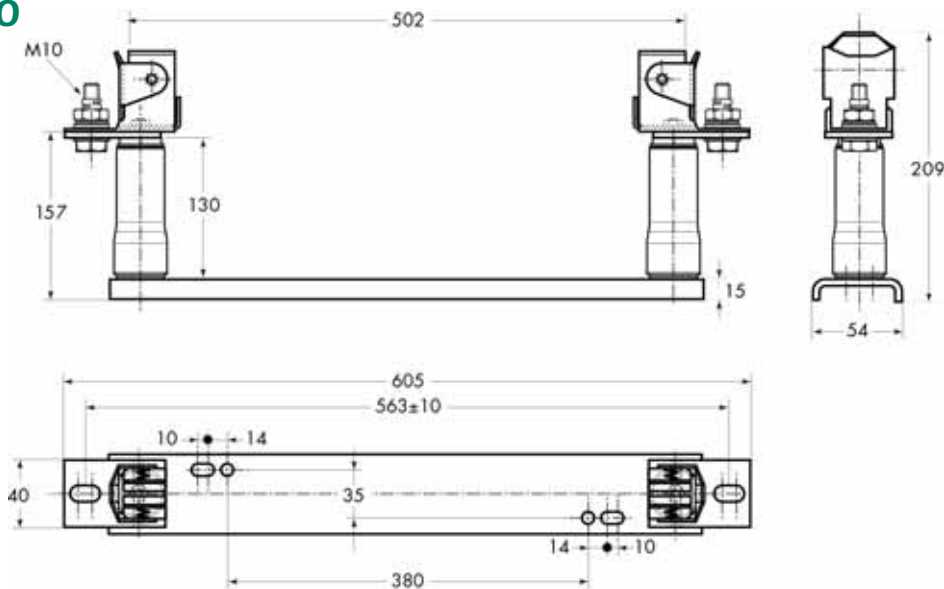

Designation	Ref. Number	Cat. Number	Weight (g)	Packaging
SPV 600	T 098963	SPV600	3 100	1

- Electrical connection of fuseholder and wires by screws made in plated steel 8-8 class (supplied with fuseholder). Maximum recommended tightening torque: 44 ± 1 Nm for M10 screw.

- Fixing of base with M8 screws. Tightening torque $10 \text{ Nm} \pm 2$.



Semiconductor Fuses AC+DC Square-boby Fuse Bases Bases for other DC Bracket Fuses - Size 70 & 602: SQ

FUSEHOLDERS FOR BRACKET STYLE CV3 FUSES

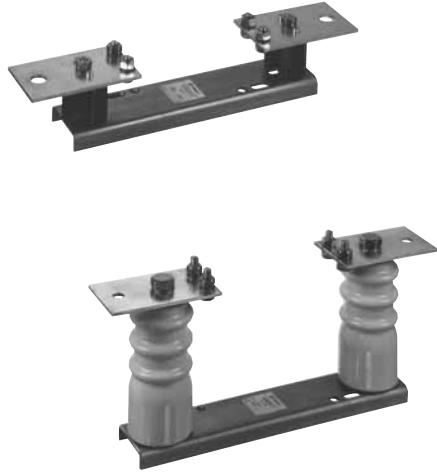

- MOUNTING IN ONE-POLE FUSEHOLDER SIMPLIFIES REPLACEMENT OF FUSES FOR INSTALLATIONS CONNECTED WITH CABLES AND BARS
- FOR BRACKET-TYPE FUSES BOLTED TIGHTENING
- "TRAC" MODELS WITH VERY HIGH COLLISION WITHSTAND FOR TRACTION COMPLYING WITH IEC 77 STANDARD

Main Characteristics

Designation	Catalog Number	Insulation voltage (V) U_i (AC 50/60 Hz & DC)	Current (A)	Dielectric withstand test (kV)		Fire and fumes class
				RMS voltage 1 mn 50/60 Hz	Impulse voltage 1.2/50 μ s	
SQ 70	SQ70	2 500	215	18 Kv	20 Kv	---
SQ 70 BS TRAC	SQ70BSTRAC	2 500	215	18 Kv	20 Kv	UL 94 VO
SQ 72	SQ72	2 500	400	18 Kv	20 Kv	---
SQ 72 BS TRAC	SQ72BSTRAC.	2 500	400	18 Kv	20 Kv	UL 94 VO
SQ 2 x 72	SQ120	2 500	840	18 Kv	20 Kv	---
SQ 2 x 72 BS TRAC	SQ122	2 500	840	18 Kv	20 Kv	Ceramic insulator
SQ 120	SQ85300	2 500	215	18 Kv	20 Kv	---
SQ 122	SQ85302	2 500	420	18 Kv	20 Kv	---
SQ 2 x 122	SQ130/2X302	2 500	900	18 Kv	20 Kv	Ceramic insulator
SQ 85 300	SQ85600	7 200	180	34 Kv	40 Kv	UL 94 VO
SQ 85 302	SQ85602	7 200	400	34 Kv	40 Kv	UL 94 VO
SQ 120 2 x 302	SQ2X72	7 200	400	34 Kv	40 Kv	Ceramic insulator
SQ 85 600	SQ2X72BSTRAC	7 200	150	34 Kv	40 Kv	UL 94 VO
SQ 85 602	SQ2X122	7 200	375	34 Kv	40 Kv	UL 94 VO
SQ 175 2 x 602	SQ1752X602	12 000	750	32 Kv	40 Kv	Ceramic insulator

No use limitation for FERRAZ SHAWMUT fuses mounted in the above holders.

Vibration withstand:

Tests with sine vibrations carried out at ambient with scanning each of the three main axes of the holder.

Spectrum: 1st segment (2 to 16 Hz) constant displacement $x = 5$ mm peak.
2nd segment (16 to 250 Hz) constant acceleration $\gamma = 5$ g peak.

Exponential scanning speed: 1 octave per minute.

Duration: 2 hours per axis.



Semiconductor Fuses

AC+DC Square-boby Fuse Bases

Bases for other DC Bracket Fuses - Size 70 & 602: SQ

Drawing #1

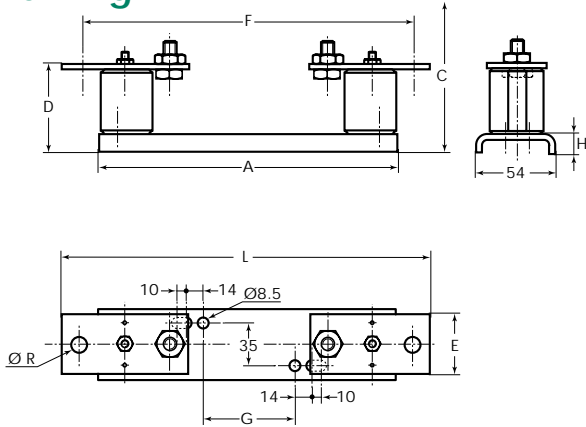

Designation	Ref. Number	Cat. Number	Weight (g)
SQ 70	G 098975		860
SQ 70 BS TRAC	M 221386		1040
SQ 72	H 098976		990
SQ 72 BS TRAC	T 098986		1065
SQ 120	K 098978		940
SQ 122	L 098979		1050
SQ 85 300	V 098481		1480
SQ 85 302	W 098482		1540
SQ 120 2 x 302	P 098982		2800
SQ 85 600	X 098483		1740
SQ 85 602	Y 098484		1935

Pack: 1 piece

Drawing #2

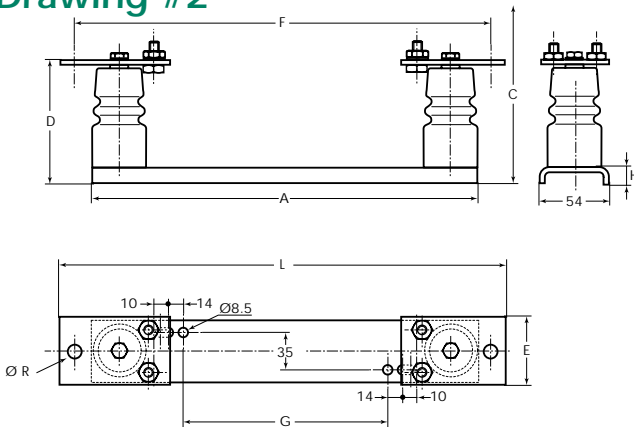

Designation	Ref. Number	Cat. Number	Weight (g)
SQ 2 x 72	J 098977		2620
SQ 2 x 72 BS TRAC	X 098989		2840
SQ 2 x 122	M 098980		2700
SQ 175 2 x 602	Q 092244		3620

Pack: 1 piece

Catalog Number	Drawing #	A	C ⁽¹⁾	D	E	F	G	H	L	Ø R*
SQ 70	1	248	106,5	51	45	293	94	15	323	10,5
SQ 72	2	248	130,5	51	60	298	94	15	333	12,5
SQ 2 x 72	2	272	222,5	148	60	298	119	14	333	12,5
SQ 120	1	302	106,5	51	45	347	148	15	377	10,5
SQ 122	2	302	130,5	51	60	352	148	11	387	12,5
SQ 2 x 122	2	326	227,5	148	60	352	173	15	387	12,5
SQ 85 300	1	377	150	103	45	398	224	15	428	10,5
SQ 85 302	2	377	175	103	60	403	224	15	438	10,5
SQ 120 2 x 302	2	377	225	148	60	403	224	15	438	10,5
SQ 85 600	1	525	150	103	45	546	372	15	576	10,5
SQ 85 602	2	525	265	190	60	551	372	15	586	10,5
SQ 175 2 x 602	2	525	265	190	60	551	372	15	586	10,5

(1) With fuse connected

- Electrical connection of fuse on fuseholder by screws made in plated steel 8-8 class (supplied with fuseholder).

Maximum recommended tightening torque: $22 \begin{smallmatrix} +0 \\ -8 \end{smallmatrix} \text{ Nm}$ for M8 screw.

- Fixing of base with M8 screws. Tightening torque $10 \text{ Nm} \pm 2$.

* Electrical connection of fuseholder and wires by screws made in plated steel 8-8 class at least (supplied in "TRAC" version and not supplied in standard version.)

Maximum recommended tightening torque: $22 \begin{smallmatrix} +0 \\ -8 \end{smallmatrix} \text{ Nm}$ for M8 screw.

$44 \begin{smallmatrix} +0 \\ -8 \end{smallmatrix} \text{ Nm}$ for M10 screw.

$76 \begin{smallmatrix} +0 \\ -8 \end{smallmatrix} \text{ Nm}$ for M12 screw.