

Technical Data Sheet

White SMD Surface Mount Device

67-21UWC/S400-AX/TR8

Features

- Fluorescence Type
- High Luminous Intensity
- High Efficiency
- Emission Color: $x=0.29,y=0.30$

Descriptions

The white LED which was fabricated using a blue LED and a phosphor, and the phosphor is excited by blue light and emits yellow fluorescence. The mixture of blue light and yellow light results in a white emission.

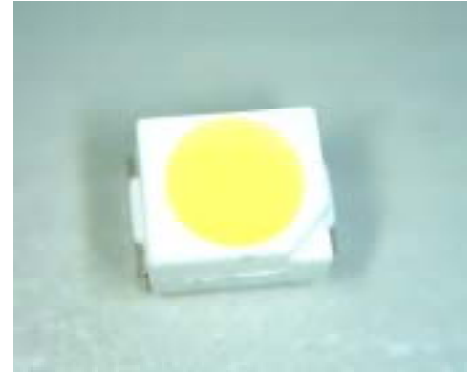

Applications

- OA Equipment
- Backlighting of Full Color LCD
- Automotive Equipment
- Replacement of Conventional Light Bulbs and Fluorescent Lamps

Device Selection Guide

Chip		Lens Color
Material	Emitted Color	
InGaN	White	Water Clear

67-21UWC/S400-AX/TR8

Package Dimensions

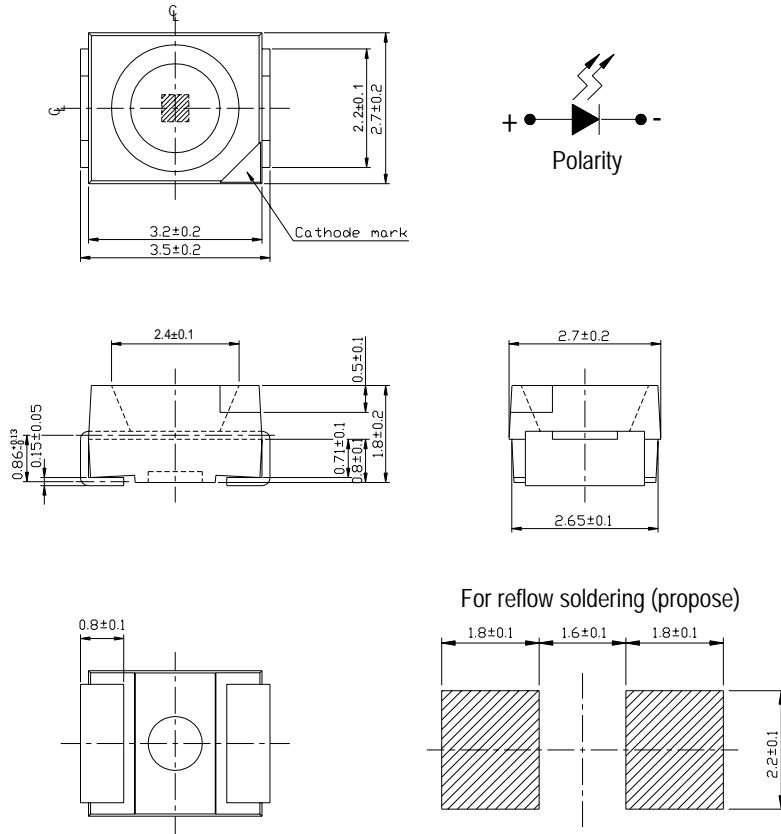

Notes: .All dimensions are in millimeters

Absolute Maximum Ratings (Ta=25)

Parameter	Symbol	Rating	Units
Forward Current	I _F	25	mA
Pulse Forward Current ^{*1}	I _{FP}	100	mA
Reverse Voltage	V _R	5	V
Power Dissipation	P _d	110	mW
Operating Temperature	T _{opr}	-40 ~ +85	
Storage Temperature	T _{stg}	-40 ~ +100	
Soldering Temperature ^{*2}	T _{sol}	260	
Electrostatic Discharge	ESD	150	V

Notes: *1:I_{FP} Conditions--Pulse Width 10msec and Duty 1/10.

*2:Soldering time 5 seconds.

67-21UWC/S400-AX/TR8

Electro-Optical Characteristics (Ta=25)

Parameter	Symbol	*Chip Rank	Min.	Typ.	Max.	Units	Condition
Luminous Intensity	I _V	A4	100	290	--	mcd	I _F =20mA
		A5	200	360	--		
		A6	240	450	--		
Forward Voltage	V _F	--	--	3.5	4.3	V	I _F =20mA
Reverse Current	I _R	--	--	--	10	μ A	V _R =5V
Viewing Angle	2 1/2	--	--	120	--	deg	I _F =20mA
Chromaticity	x	--	--	0.29	--	--	I _F =20mA
Coordinates	y	--	--	0.30	--	--	I _F =20mA

*67-21UWC/S400-AX/TR8

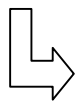

Chip Rank

Notes: *The C.I.E. 1931 chromaticity diagram.

*The products are sensitive to static electricity and care must be fully taken when handling products.

Chromaticity Coordinates Specifications for Bin Grading

Color grading		CIE_x		CIE_y	
		Min	Max	Min	Max
A		0.22	0.27	0.215	0.315
B	B1	0.25	0.285	0.245	0.325
	B2	0.265	0.3	0.255	0.335
C	C1	0.28	0.315	0.265	0.345
	C2	0.295	0.33	0.275	0.355
D		0.31	0.37	0.285	0.385

67-21UWC/S400-AX/TR8

CIE Chromaticity Diagram

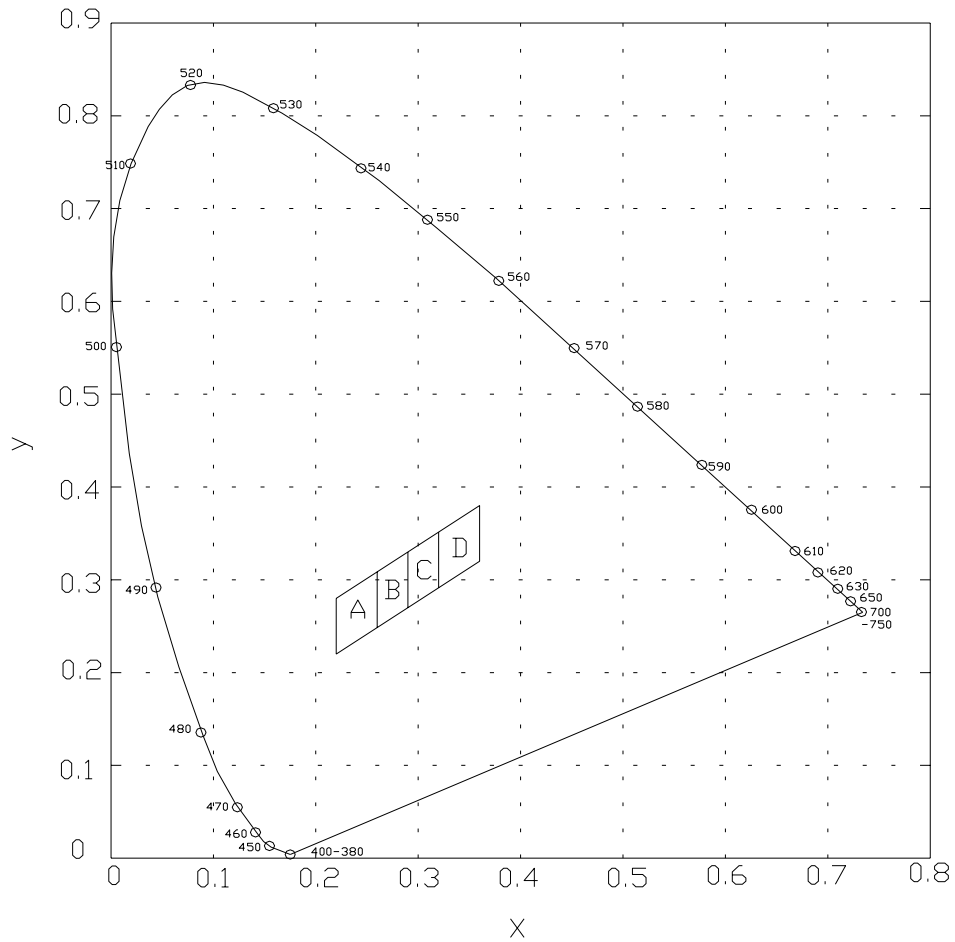

67-21UWC/S400-AX/TR8

Typical Electro-Optical Characteristics Curves

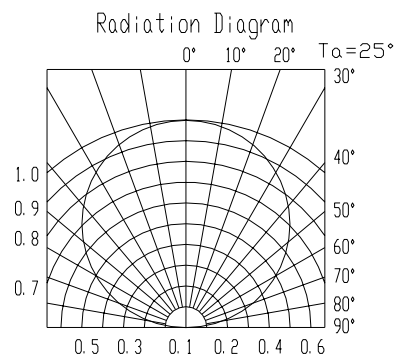
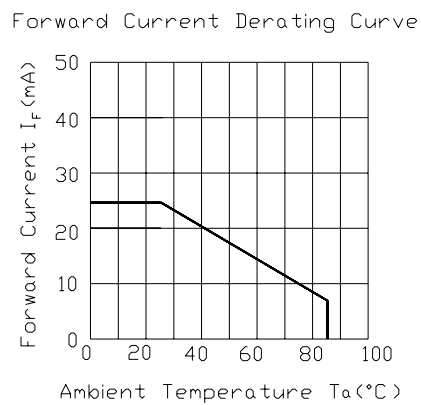
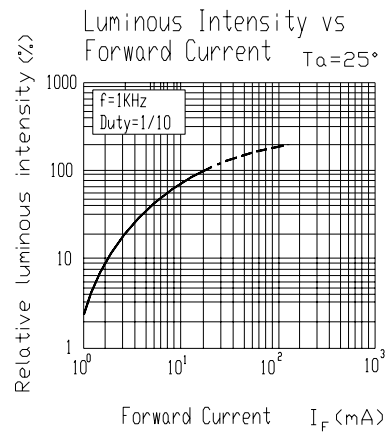
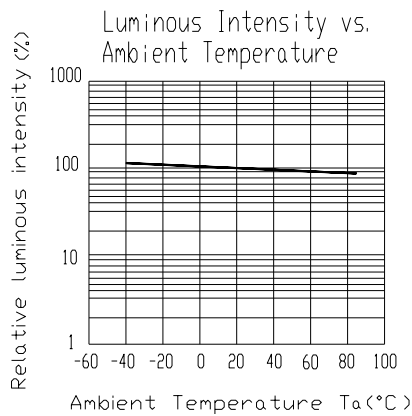
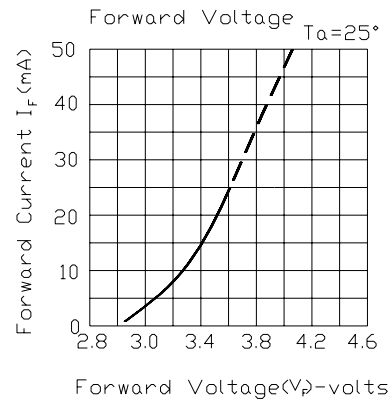
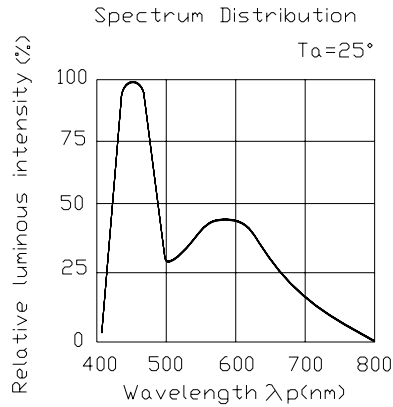

67-21UWC/S400-AX/TR8

Label explanation

CAT: Luminous Intensity Rank

HUE: Dom. Wavelength Rank

REF: Forward Voltage Rank

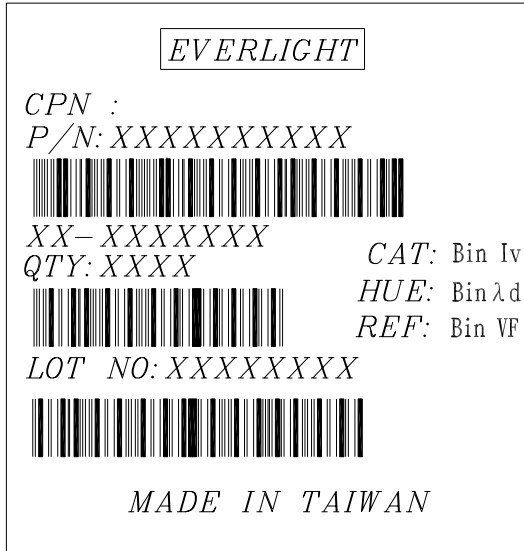

Reel Dimensions

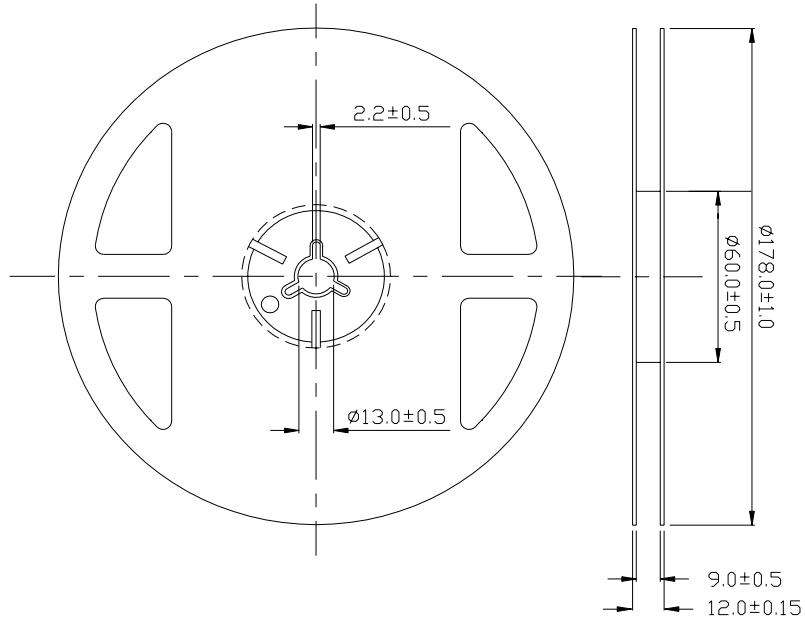

Note: The tolerances unless mentioned is $\pm 0.1\text{mm}$,Unit = mm

67-21UWC/S400-AX/TR8

Carrier Tape Dimensions: Loaded quantity 2000 PCS per reel.

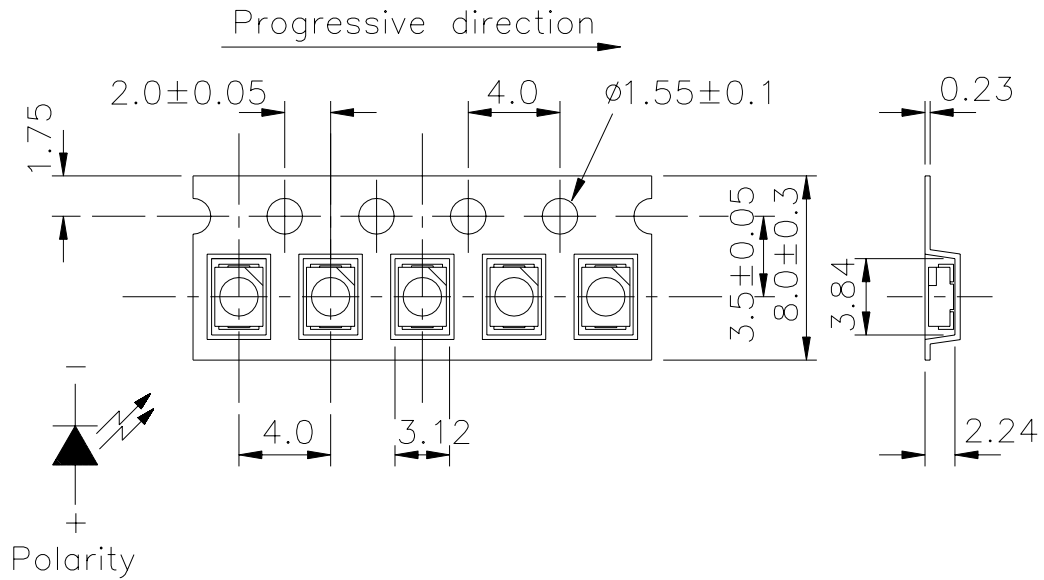

Note: The tolerances unless mentioned is ±0.1mm , Angle±0.5°Unit = mm

Moisture Resistant Packaging

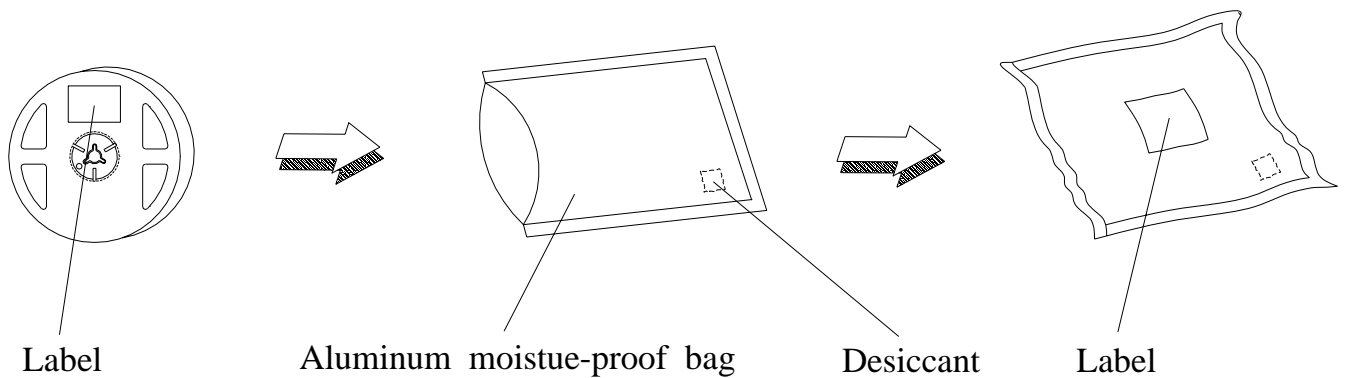

67-21UWC/S400-AX/TR8

Reliability Test Items And Conditions

The reliability of products shall be satisfied with items listed below.

Confidence level : 90%

LTPD : 10%

No.	Items	Test Condition	Test Hours/Cycles	Sample Size	Ac/Re
1	Reflow Soldering	Temp. : 240 ±5 5sec.	6 min	22 PCS.	0/1
2	Temperature Cycle	H : +100 15min 5 min L : -40 15min	300 Cycles	22 PCS.	0/1
3	Thermal Shock	H : +100 5min 10 sec L : -10 5min	300 Cycles	22 PCS.	0/1
4	High Temperature Storage	Temp. : 100	1000 Hrs.	22 PCS.	0/1
5	Low Temperature Storage	Temp. : -40	1000 Hrs.	22 PCS.	0/1
6	DC Operating Life	I _F = 20 mA	1000 Hrs.	22 PCS.	0/1
7	High Temperature / High Humidity	85 /RH85%	1000 Hrs.	22 PCS.	0/1

67-21UWC/S400-AX/TR8

Precautions For Use

1. Over-current-proof

Customer must apply resistors for protection , otherwise slight voltage shift will cause big current change (Burn out will happen).

2. Storage

- 2.1 Do not open moisture proof bag before the products are ready to use.
- 2.2 Before opening the package, the LEDs should be kept at 30 or less and 90%RH or less.
- 2.3 The LEDs should be used within a year.
- 2.4 After opening the package, the LEDs should be kept at 30 or less and 70%RH or less.
- 2.5 The LEDs should be used within 168 hours (7 days) after opening the package.
- 2.6 If the moisture absorbent material (silica gel) has faded away or the LEDs have exceeded the storage time, baking treatment should be performed using the following conditions.
Baking treatment : 60±5 for 24 hours.

3. Soldering Condition

3.1 Lead solder temperature profile

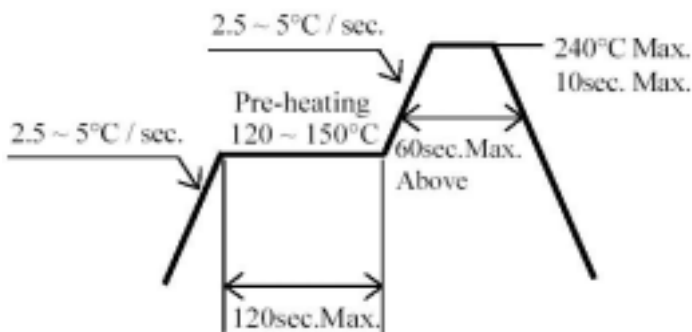

- 3.2 Reflow soldering should not be done more than two times.
- 3.3 When soldering, do not put stress on the LEDs during heating.
- 3.4 After soldering, do not warp the circuit board.

4. Soldering Iron

Each terminal is to go to the tip of soldering iron temperature less than 280 for 3 seconds within once in less than the soldering iron capacity 25W. Leave two seconds and more intervals, and do soldering of each terminal. Be careful because the damage of the product is often started at the time of the hand solder.

67-21UWC/S400-AX/TR8

5.Repairing

Repair should not be done after the LEDs have been soldered. When repairing is unavoidable, a double-head soldering iron should be used (as below figure). It should be confirmed beforehand whether the characteristics of the LEDs will or will not be damaged by repairing.

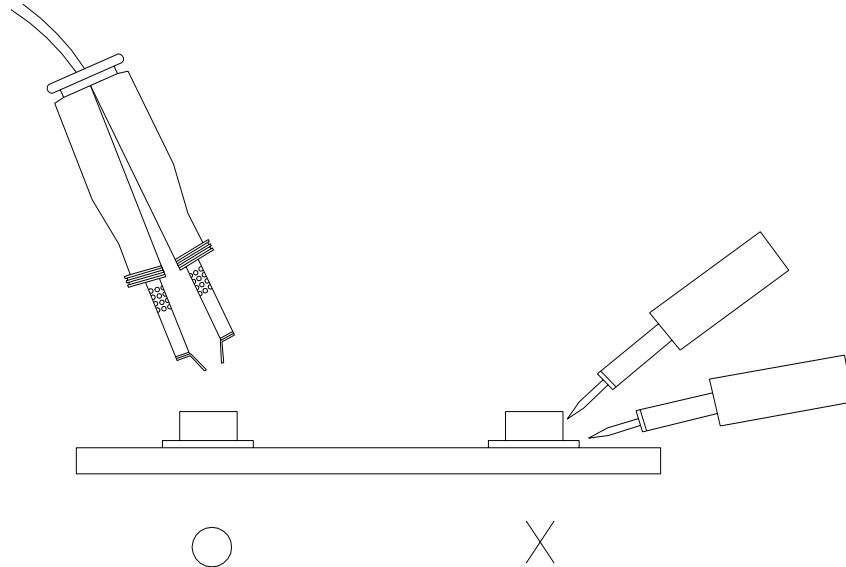

EVERLIGHT ELECTRONICS CO., LTD.
Office: No 25, Lane 76, Sec 3, Chung Yang Rd,
Tucheng, Taipei 236, Taiwan, R.O.C

Tel: 886-2-2267-2000, 2267-9936
Fax: 886-2267-6244, 2267-6189, 2267-6306
<http://www.everlight.com>