

Safety Switches with Plastic Housing



EUCHNER

More than safety.

EUCHNER

More than safety.



Headquarters in Leinfelden-Echterdingen



Logistics center in Leinfelden-Echterdingen



Production location in Unterböhringen

Internationally successful – the EUCHNER company

EUCHNER GmbH + Co. KG is a world-leading company in the area of industrial safety technology. EUCHNER has been developing and producing high-quality switching systems for mechanical and systems engineering for more than 60 years.

The medium-sized family-operated company based in Leinfelden, Germany, employs around 750 people around the world.

18 subsidiaries and other sales partners in Germany and abroad work for our international success on the market.

Quality and innovation – the EUCHNER products

A look into the past shows EUCHNER to be a company with a great inventive spirit. We take the technological and ecological challenges of the future as an incentive for extraordinary product developments.

EUCHNER safety switches monitor safety doors on machines and installations, help to minimize dangers and risks and thereby reliably protect people and processes. Today, our products range from electromechanical and electronic components to intelligent integrated safety solutions. Safety for people, machines and products is one of our dominant themes.

We define future safety technology with the highest quality standards and reliable technology. Extraordinary solutions ensure the great satisfaction of our customers.

The product ranges are subdivided as follows:

- ▶ Transponder-coded Safety Switches
- ▶ Transponder-coded Safety Switches with guard locking
- ▶ Multifunctional Gate Box MGB
- ▶ Access management systems (Electronic-Key-System EKS)
- ▶ Electromechanical Safety Switches
- ▶ Magnetically coded Safety Switches
- ▶ Enabling Switches
- ▶ Safety Relays
- ▶ Emergency Stop Devices
- ▶ Hand-Held Pendant Stations and Handwheels
- ▶ Safety Switches with AS-Interface
- ▶ Joystick Switches
- ▶ Position Switches



Safety Switches with Plastic Housing

General	4
About this catalog	4
How can I find the right switch?	4
Standards and approvals	5
Function and technology used in safety switches	5
Safety switches type 1, plastic housing	13
Safety switches NM	13
Safety switches type 2, plastic housing	21
Safety switches NM..VZ	21
Safety switches NP	25
Safety switches GP	31
Safety switches SGP	35
Safety switches SGA, metal housing	39
Safety switches TP with guard locking and guard locking monitoring	43
Safety switches STP with guard locking and guard locking monitoring	61
Safety switches STA with guard locking and guard locking monitoring, metal housing	75
Safety switches STM with guard locking and guard locking monitoring	83
Safety switches with guard locking pin, plastic housing	85
Safety switches TK with guard locking (without failsafe locking mechanism)	85
Accessories for safety switches	89
Actuators	90
Insertion funnels/adapters	100
Mounting plates	101
Plug connector	103
Cable glands/LED indicators	108
Miscellaneous accessories	110
Bolts for guards	112
Technical data	121
Appendix	152
Glossary	152
Item index	157
Index by item designation	157
Index by order number	162

About this catalog

The *Safety Switches with Plastic Housing* catalog gives you an overview of our safety switches and our rope pull switches. For numerous applications these switches are the right choice due to their economy and flexibility. You will find the technical data after the product overview. There is a reference to the page with the related technical data on the pages listing the products.

At the front of the catalog you will find useful information on the topic of safety switches. We have prepared an overview of the standards and a glossary on this topic in the appendix.

You will find the following series and accessories in this catalog:

Safety switches with plastic housing											TK	Accessories
Type 1	Type 2								TK	Accessories		
NM	Without guard locking				With guard locking and guard locking monitoring						TK	Accessories
	NM..VZ	NP	GP	SGP	SGA ¹⁾	TP	STP	STA ²⁾	STM			
See page 13	See page 21	See page 25	See page 31	See page 35	See page 39	See page 43	See page 61	See page 75	See page 83	See page 85	See page 89	

1) Switch interchangeable with the SGP; in metal housing

2) Switch interchangeable with the STP; in metal housing

How can I find the right switch?

There are two ways you can find the right switch:

1) If you know the order number or the product designation, look for the switch directly in the item index (see page 157 or page 162).

2) If you have specific requirements, refine the selection step-by-step with the aid of the table of contents and the selection tables.

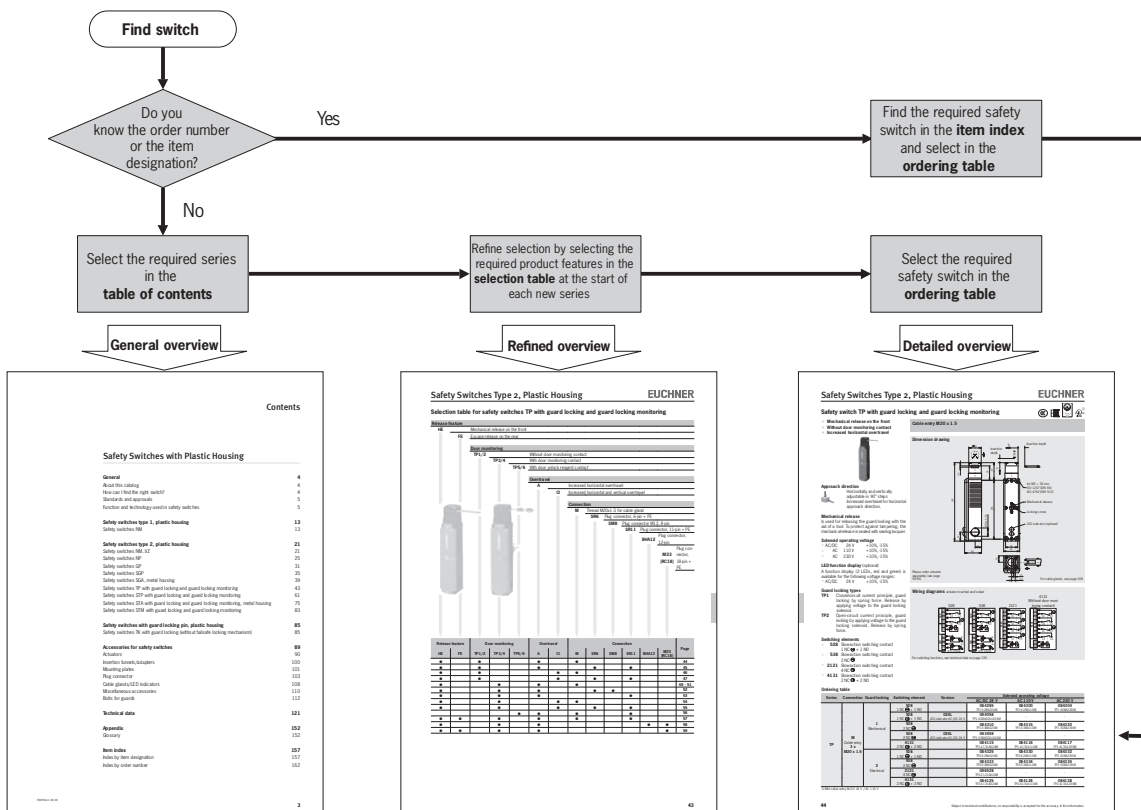

Standards and approvals

Standards

Safety switches must meet the requirements for safety components as per the Machinery Directive. The Machinery Directive has been implemented in national law in the EU member states and, as a result, is binding for all manufacturers.

Detailed requirements for the switches are defined in DIN EN 60947-5-1 (Low-voltage switchgear and controlgear – Part 5-1: Control circuit devices and switching elements. Electromechanical control circuit devices).

If the requirements of this standard are met, conformity with the applicable laws and therefore with the Machinery Directive is assumed. EUCHNER safety switches comply with the relevant standards for safety switchgear and therefore help you to comply with safety requirements during the design of your machinery.



Approvals

To demonstrate conformity, the Machinery Directive also includes the possibility of type examination. Although all relevant standards are taken into account during development, we have all our safety switches subjected to additional type examinations by a notified body.



Many of the safety switches listed in this catalog have been tested by the German Social Accident Insurance association (DGUV), formerly the employers' liability insurance association (BG), and are given in the lists from the DGUV.

Furthermore, numerous switches are listed by Underwriters Laboratories (UL) or other organizations. These switches can be used in countries in which this listing is required. The approval symbols on the individual pages of the catalog indicate which body tested the switches.

With the aid of the approval symbols listed below you can quickly see which approvals are available for the related switches:

	<p>Switches with this symbol have the approval of the German Social Accident Insurance association (DGUV) – formerly the employers' liability insurance association (BG)</p>
	<p>Switches with this symbol are approved by Underwriters Laboratories (UL, Canada and USA)</p>

Special approvals

	<p>Switches with this symbol are approved by DNV GL, formerly Germanischer Lloyd</p>
	<p>Switches with this symbol are approved by the Eurasian Economic Union (EEU)</p>
	<p>Switches with this symbol have CCC certification for the Chinese market.</p>

Function and technology used in safety switches

The task of safety switches

Safety switches have the task of preventing the operation of a machine in the case of a potential hazard. This task is defined in EN ISO 14119 (Safety of machinery. Interlocking devices associated with guards. Principles for design and selection). For this purpose the safety circuit must be opened by the safety switch. Safety switches are therefore key elements of an interlocking device.

In this context an interlocking device is, for example, the interruption of machine operation if the safety door is open – the stop state of the machine is “interlocked” so to speak and unintentional starting is therefore prevented. In relation to movable guards this means that if safety doors or safety flaps are open, the machine or system cannot be operated if the machine or system can produce a hazard. For this reason the safety switch for a guard must be attached such that a malfunction is excluded. Safety switches must also not be tampered with or bypassed. The most important feature of a safety switch is at least one NC contact that is operated positively. The switching contacts are separated positively when the guard is opened.

Safety switch types according to EN ISO 14119

Safety switches in this catalog are divided into two different functional types. Switches type 1 are actuated by an actuator (e.g. a dog or some type of end stop).

For safety switches type 2 a special, coded actuator is required. The actuator therefore has a specific form (similar to a key). Other types are defined in EN ISO 14119.

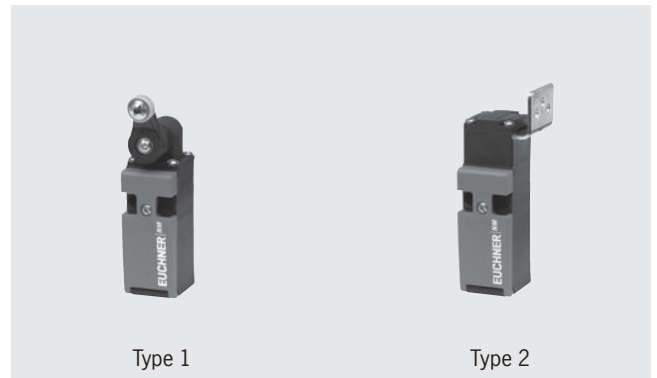

Safety switches type 1

Safety switches type 1 are safety switches on which the actuating element for the switch is coded. The actuating elements are available in various versions (e.g. in the form of a plunger or a lever arm).

To actuate a switch type 1, trip dogs or cams are often used. The switch must be attached such that the switch is actuated if the guard is opened. The positively driven contact in the switching element is opened, and the machine is shut down. A built-in spring in the switch returns the switch to the free position when the guard is closed and the positively driven contact is closed. In this way the safety circuit is enabled again. A trip dog with a defined slope should be used to approach the switch. EUCHNER has various trip dogs in its range.

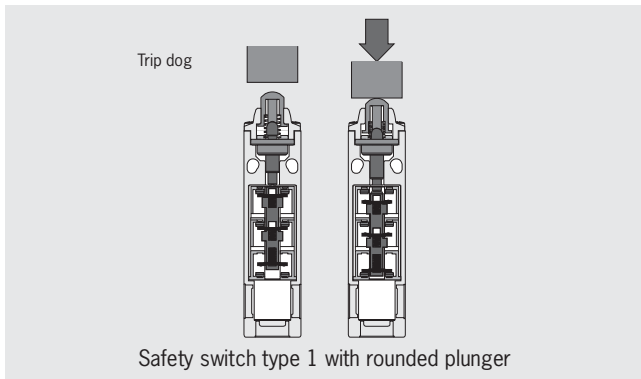

Safety switches type 2

On safety switches type 2, the actuating element for the switch is coded. The actuating elements are available in various versions to suit the guard that is to be monitored.

This catalog contains series NM.VZ, NP, GP, TP, STP and STM switches that are used in combination with separate coded actuating elements. The function of these switches is, apart from the type of actuation, identical to the switches type 1.

Actuating elements for switches type 2

The safety switches NM.VZ, NP, GP, TP, STA, SGP, STP and STM can only be actuated using a special, coded actuating element. The coding is a type of lock and key principle. The safety switch can only be actuated using an actuating element of a specific shape. Unlike a conventional key, the actuating elements for a switch series are always the same shape.

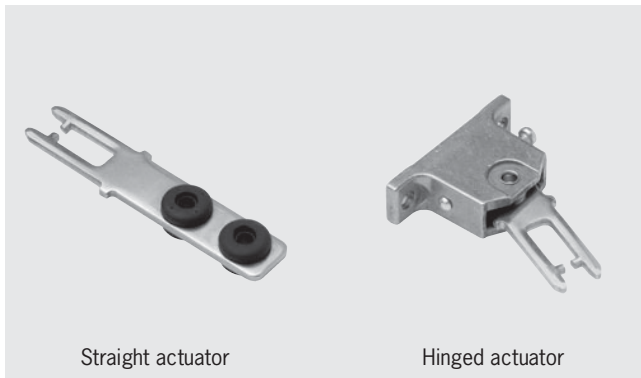

The positively driven contact in the switching element is closed by inserting the actuating element in the switch head. The positively driven contact is reliably opened by the positive application of force when the actuating element is removed – even if the contacts are welded together. In the open state, the machinery or systems are then safely interlocked against starting.

Straight actuators and hinged actuators are available for a wide range of applications in which hinged and sliding doors are used. Hinged actuators are spring-mounted actuators that adjust to the inner contours of the switch on insertion in the actuating head. They are suitable for small hinged doors with a radius from 90 mm. For sliding doors and hinged doors with an adequately large pivoting radius, a straight actuator can be used.

If increased play is required when the door is closed, an actuator with overtravel is available. With this actuator the door can move slightly in the actuating direction when closed. This is important, for example, if safety doors have a rubber end stop. Using an actuator with overtravel, the continuous pressure from the compressed rubber can be reduced. In this way the load is reduced on the switch head and the door mechanism.

Switching elements

Different switching elements are available for the switches offered in the catalog:

- ▶ Single switching element
- ▶ Double switching element with two independent switching contacts
- ▶ Triple switching element with three independent switching contacts
- ▶ Quadruple switching element with four independent switching contacts

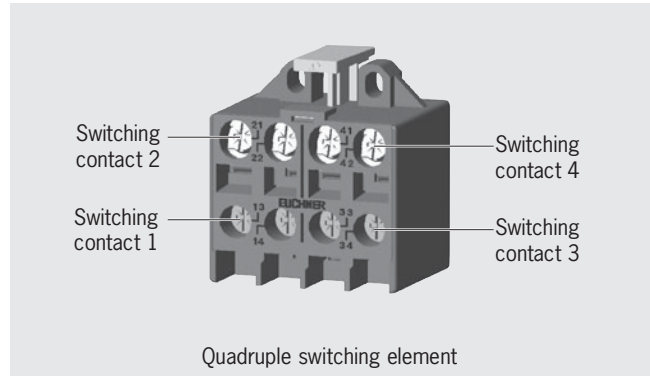

Only one switching element is fitted in each case in switches of the series NM, NP, GP, TP, STA, SGP, STP and TK. Two switching elements are fitted to all series STM safety switches. In this case one of the switching elements is used to monitor the door position (SK) and the other is used to monitor the position of the guard locking solenoid (ÜK).

Switching elements are divided into two types as a function of their switching characteristics:

- ▶ Slow-action switching elements and
- ▶ Snap-action switching elements

Slow-action switching element

Slow-action switching elements are mostly used in safety switches. The opening of the switching element is directly dependent on the position of the actuator. The further the actuator is moved, the further the switching element is opened. The actuator travel is therefore directly proportional to the distance covered by the switching contact in the switching element. From the travel diagrams it can be seen at which point the switching element changes from the closed state to the open state.

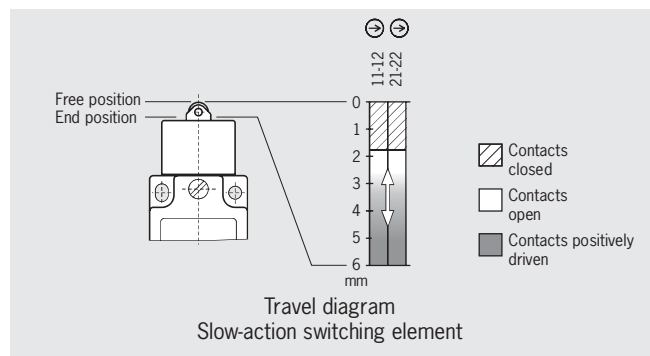

Snap-action switching element

On snap-action switching elements, the change from the completely closed state to the completely open state is made at a defined point. As a result the operating point is at a defined position, unlike on slow-action contact elements. Snap-action switching elements typically have a switching hysteresis. No snap-action switching elements are available for the safety switches in this catalog.

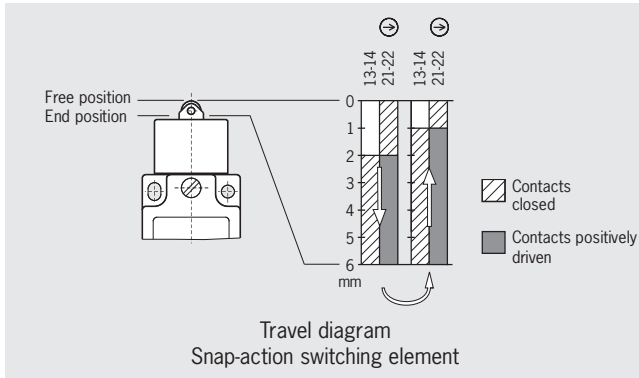

Positively driven contacts

Positively driven contacts are used in the switching elements. These are special switching contacts that are designed to ensure the switching contacts are always reliably separated. Even if contacts are welded together, the connection is opened by the actuating force.

It is a common feature of all safety switching elements that at least one switching contact is designed as a positively driven contact. Often two positively driven contacts are employed to increase safety using the principle of duplicated design (redundancy). This dual-channel design ensures that on the failure of one channel or on a fault in the control circuit (e.g. in the machine wiring), the interlocking can still be provided with the aid of the second channel.

Switches must also meet the requirements of EN 60947-5-1 Annex K.

Guard locking monitoring

The monitoring by the control system must be marked with the symbol shown on the illustration. This switching contact is a positively driven contact. The contacts are opened when guard locking is released.

Explanation of symbols and notation

Symbols and specific notation related to the switches or the switching contact are used time and again in the catalog.

The following example is intended to explain these aspects:

Notation

1 NC + 1 NO

Explanation

Normally closed contacts are represented by NC, normally open contacts by NO. The number defines how many contacts are available. The symbol behind the NC defines that the NC contact is a positively driven contact. This switch therefore has one normally closed contact and one normally open contact; the normally closed contact is a positively driven contact.

Safety contacts

If contacts fulfill safety tasks, positively driven contacts must be used. These contacts are referred to as safety contacts.

Monitoring contacts

Door monitoring contact and interlocking solenoid monitoring contact

In addition to the safety contacts, monitoring contacts are also required, for example, to indicate the position of the guard locking solenoid in the control system, or to indicate whether the guard is open. If these contacts do not have any safety function, either NC or NO contacts can be used.

Door unlock request contact

A special feature of the TP series is the door unlock request contact. When the actuator is in the locked state, positively driven contact 21-22 is opened by pulling the guard and a signal sent to the higher level PLC. Depending on the control concept, the guard can be unlocked automatically – when machine components that were still running have stopped.

Protection against tampering

A safety switch can only ensure that operation is free of hazards if it is not bypassed. To prevent tampering with a separate actuator type 2, the actuator must be positively mounted on the guard. All actuating elements are supplied with safety screws that can be fastened using commonly available tools, but that can only be undone with extreme difficulty. It should be ensured that the screws cannot be undone with simple tools. Increased protection against bypassing safety switches can be achieved by using a covered installation. In this way it can be made more difficult to insert replacement actuators, or this action can be prevented. Suitable for this purpose, for instance, are rear wall mounting or guiding the actuator in a C rail.

Switches type 1 can be installed covered so that the uncoded actuating element cannot be reached.

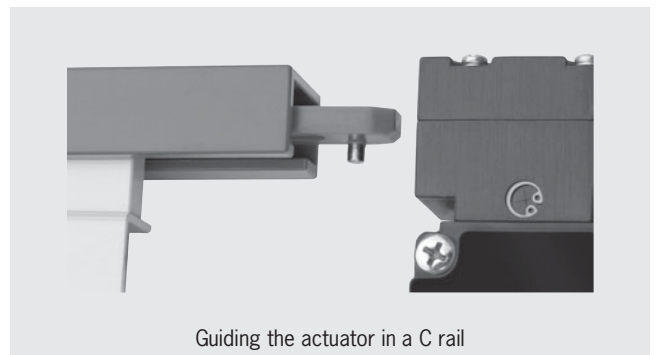

Lockout bar

To prevent the unintentional closing of a guard, lockout bars are available for switches type 2. The lockout bar is inserted in the safety switch instead of the actuator when the guard is open. The lockout bar can then be secured with commercially available padlocks (up to three locks) to protect against removal.

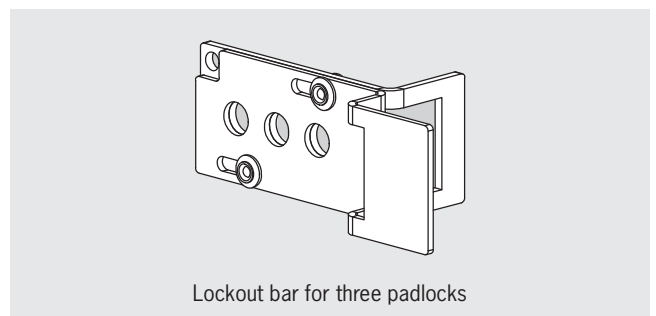

This feature guarantees protection for anyone (e.g. maintenance or service personnel, or cleaning staff) who needs to enter potentially hazardous areas. The switches cannot signal a safe (closed) state with a lockout bar fitted. As a result unintentional starting of the machine is not possible.

Guard locking

Safety switches type 2 are available both with and without guard locking. Guard locking is a feature that prevents the unintentional opening of a door as long as there is a hazard. The door is locked by preventing the removal of the actuator from the safety switch.

The series TP, STA, STP and STM listed in this catalog are safety switches type 2 with guard locking. The safety switch TK also features guard locking but does not have a *failsafe locking mechanism*. It can therefore not be classified as a classic switch type 1 or type 2.

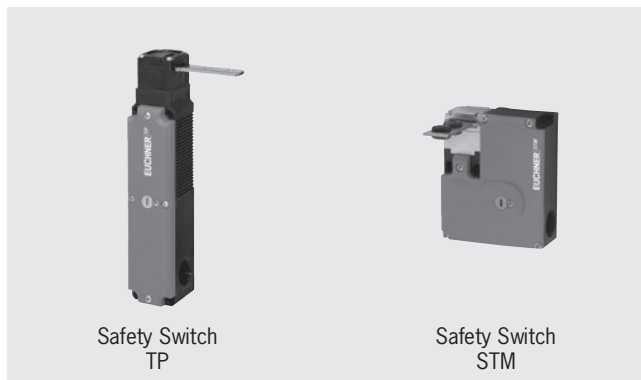

Personnel protection

Guard locking is required if a hazard cannot be removed immediately by shutting down a machine (e.g. due to machine movements with overtravel). In this case fail-safe control of the guard locking solenoid is required. This requirement can, for instance, be achieved by a safe standstill monitor or a safe delay. The safety switch must also provide a facility for monitoring the position of the solenoid.

The series TP, STP, STM and TK feature the *guard locking monitoring* required for this function and can therefore be used for protection of personnel.

Process protection

Often a guard is only to be locked to prevent interruption to the process due to unintentional opening of the guard. In this case the position of the guard locking solenoid does not need to be integrated in the safety circuit.

Housing material and actuating head

The safety switches in this catalog have a housing made of fiber glass reinforced thermoplastic. Due to the durable housing material and the high degree of protection (up to IP 67), these switches can be used even under severe conditions. The degree of protection only applies to the space for the electrical wiring and not to the actuating head.

If there are increased demands on the load capability of the actuating head in operation, it is possible to choose an actuating head made of metal in the STM series. Alternatively, you can choose the STP series, which is equipped with a metal head as standard. This allows you to combine the economy of safety switches with a plastic housing with the ruggedness of safety switches made of metal.

Attaching safety switches type 1, type 2 and the actuators

Certain requirements must be met with respect to attaching the safety switches, e.g. EN ISO 14119 *Safety of machinery - Interlocking devices associated with guards - Principles for design and selection*.

Any installation position can be used. However, the safety switches must be attached such that their position cannot be changed in operation. However, it must be possible to replace the switches at any time, if necessary, without renewed adjustment.

These requirements are achieved by using reliable attachments that can only be undone using tools. To prevent a change to the position, there must also be no movement in the joint (e.g. by using dowel pins).

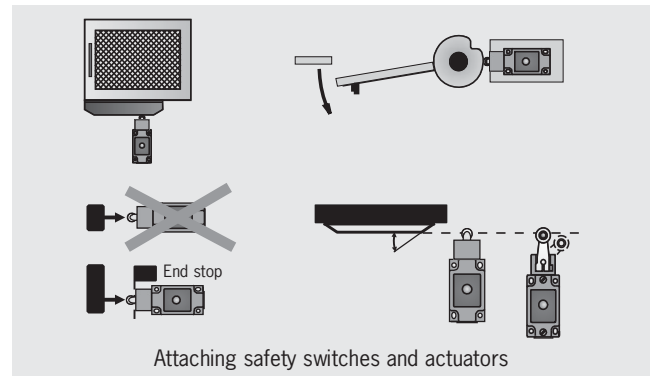

The same applies to the actuators for switches type 2 and trip dogs for switches type 1. A joint without movement is also required here. Above all else, loosening must be prevented. In addition, it must be ensured that cams and trip dogs can only be mounted in the correct position.

To prevent tampering, safety screws can also be used for the attachment of safety switches and trip dogs.

Changing the approach direction

Often the actuator approach direction does not match the standard alignment of the actuating head as delivered. For this reason, the actuating heads on the safety switches NM, NP, GP, TP, STA, SGP and STP can be very easily adjusted to the required direction.

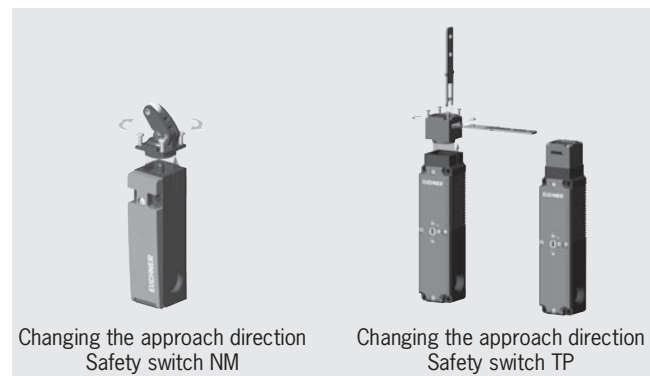

After undoing the four fixing screws, the actuating head can be rotated in 90° steps. If for reasons of protection against tampering, renewed removal of the actuating head is to be prevented, the actuating head can be fastened to the basic housing using safety screws. You will find appropriate fixing material in the accessories section of this catalog.

Changing the switching direction

In addition, in the case of the NM.HB series, the actuating direction can be adjusted such that the actuator only switches in one direction.

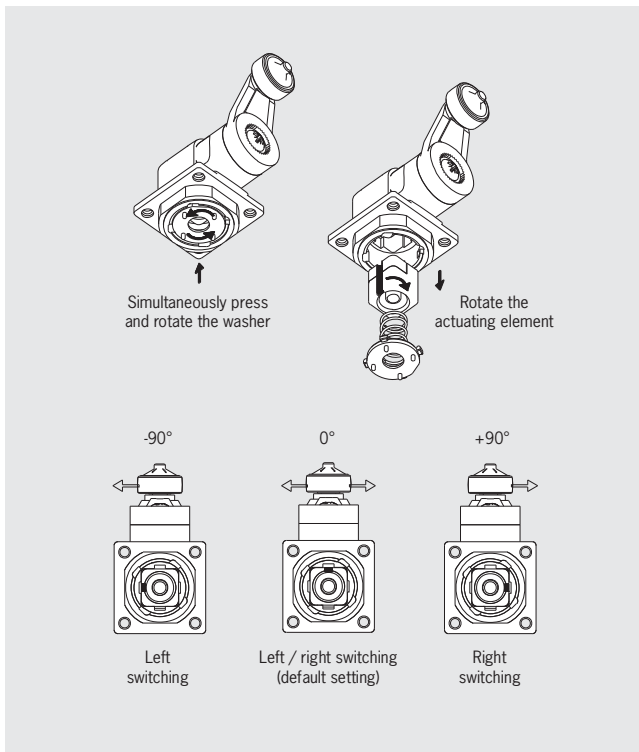

Electrical connection

On switches with cable entry there is a large space envelope for making the electrical connection. Modern wiring concepts increasingly utilize plug-in connections. A switch with plug connectors can be easily replaced during servicing work. This configuration results in short downtimes. The safety switches in this catalog are available with various plug connectors. The corresponding mating connectors are also available as accessories with permanently connected cables of different lengths.

Switch layout for STM series

- ▶ Locking arm
The locking arm ensures that the switch is guard locked by the solenoid. It acts directly on the switching element ÜK; the positively driven contacts can only be closed in the locked state (see *Failsafe locking mechanism*, page 11).
- ▶ SK
The position of the switching contacts of the SK switching element is dependent on the position of the actuator or the guard. This situation means that the positively driven contacts on the SK switching element are only closed if the actuator is in the switch head.
- ▶ ÜK
The position of the switching contacts of the ÜK switching element is dependent on the position of the actuator or the guard and the position of the solenoid or the guard locking.

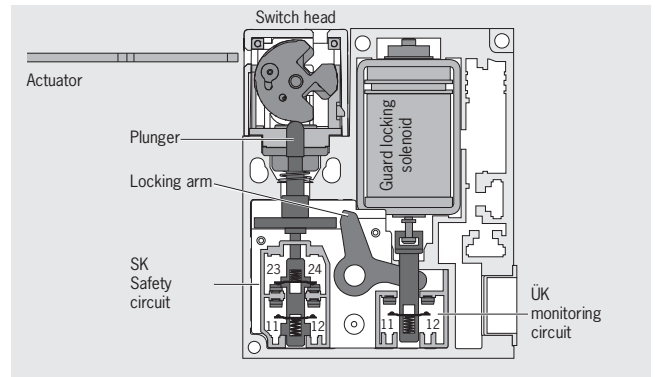

Principle of operation of STM

The sectional drawings show the safety switch STM in its three switch states:

- 1 Door open and not locked
In the initial state (actuator removed/guard open) all positively driven contacts (SK and ÜK) are open. The NO contact 23-24 is closed and signals the condition *Door open and not locked*. Unintentional closing of the contacts on switching element ÜK is impossible due to the switch mechanism (see *Failsafe locking mechanism*, page 11).

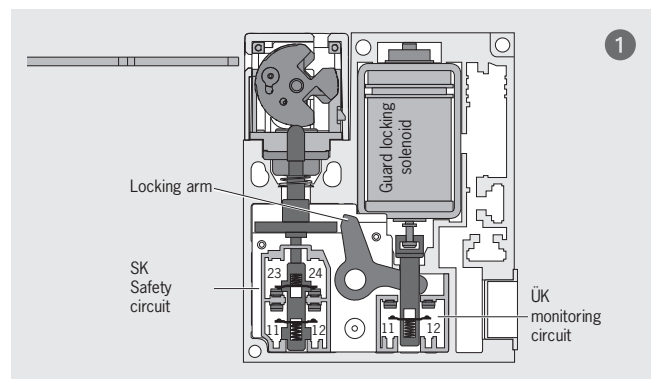

- 2 Door closed and not locked
The plunger is released by inserting the actuator into the switch head. The contacts 11-12 on switching element SK are closed, the contacts 23-24 are opened. The contacts 11-12 of the switching element ÜK remain open as before.

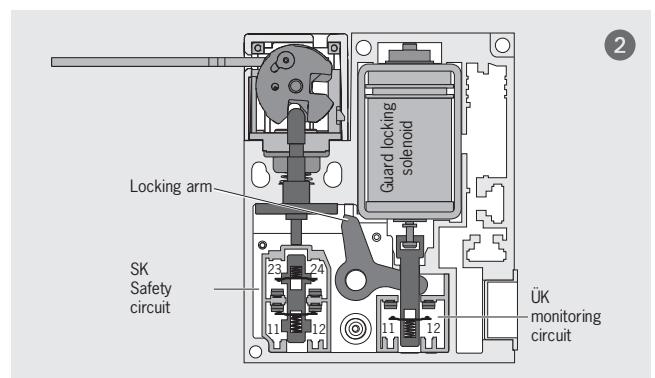

3 Door closed and locked

After the actuator has been inserted, it is possible to activate the switch's guard locking. If the guard locking solenoid is activated, the locking arm locks the plunger and actuates the switching element ÜK. The contacts 11-12 are closed on this switching element. The contacts 11-12 on the switching element SK continue to remain closed. In this position the positively driven contacts 11-12 on the two switching elements SK and ÜK are safely locked, the monitoring contact 23-24 is open. The actuator and the guard are locked. This means that the machine connected to the safety circuit can be started.

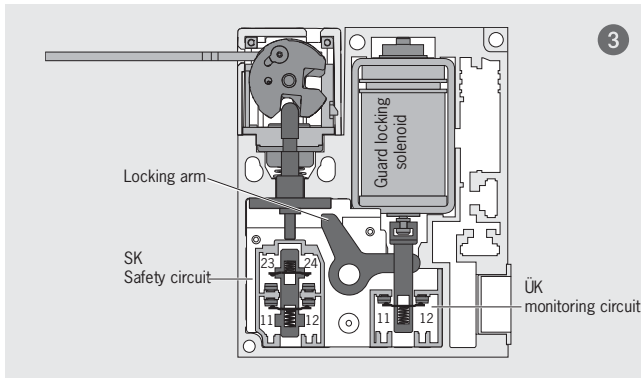

Principle of operation of TP/STA/STP

The sectional drawings show the safety switch TP/STP in its three switch states:

1 Door open and not locked

In the initial state (actuator removed/guard open) all positively driven contacts (here: 21-22 and 41-42) are open. The NO contact 13-14 is closed and signals the condition *Door open*. The NO contact 33-34 is also closed and signals the condition *Not locked*. Unintentional closing of the contacts 21-22 and 41-42 is impossible due to the switch mechanism (see *Failsafe locking mechanism*, page 11).

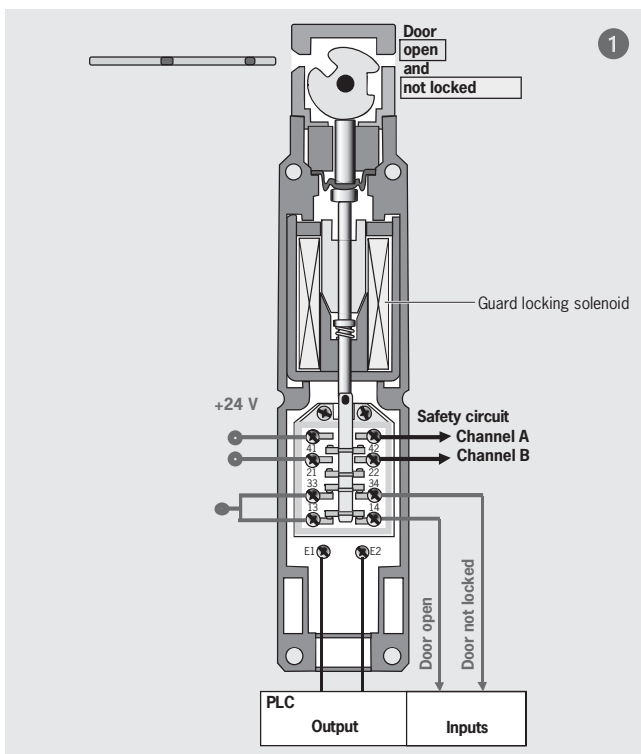

2 Door closed and not locked

The plunger is released by inserting the actuator into the switch head. The NO contact 13-14 is now open and signals the condition *Door closed*. The NO contact 33-34 remains closed and signals the condition *Not locked* as before. The positively driven contacts 21-22 and 41-42 remain open as before.

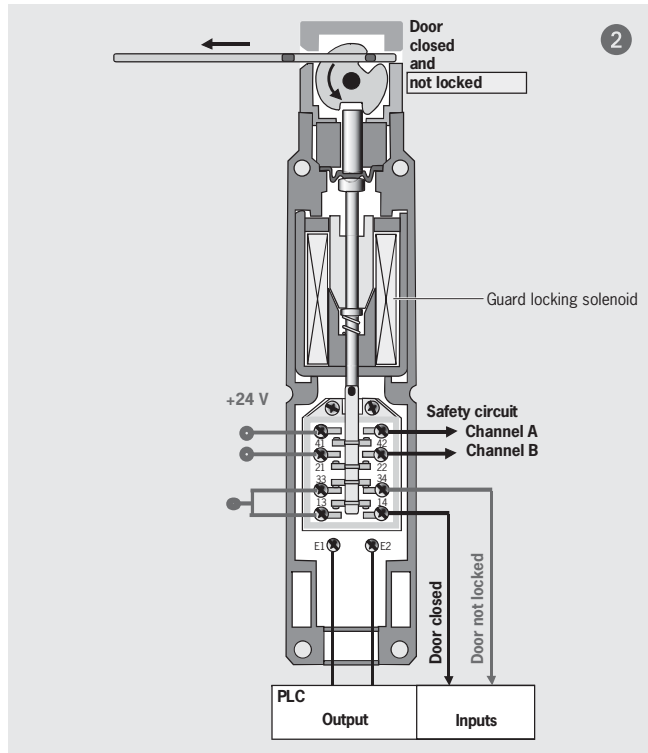

3 Door closed and locked

After the actuator has been inserted, it is possible to activate the switch's guard locking. When the guard locking solenoid is activated, NO contact 33-34 is opened and signals the condition *Locked*. The NO contact 13-14 signals the condition *Door closed* as before. The positively driven contacts 21-22 and 41-42 were closed when the guard locking solenoid was activated. The actuator and the guard are locked. This means that the machine connected to the safety circuit can be started.

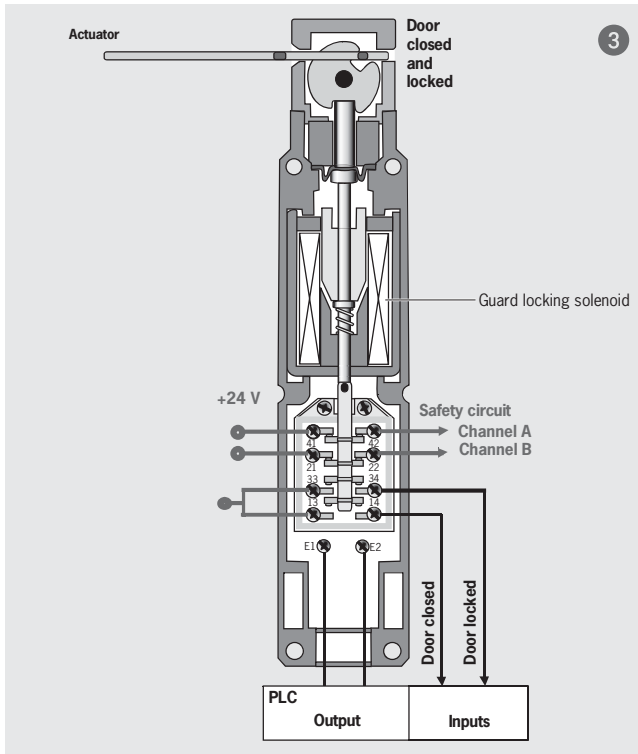

Principle of operation, BiState version

The switch has, in addition to the mechanical/electrical guard locking, fixing for the guard locking pin. The guard locking pin is held in its current position if the operating voltage is not present. The guard locking pin can be moved only by applying the operating voltage.

In case of interruption of the power supply (operating voltage) for the switch or if the machine is switched off for servicing, for example, the guard locking pin is held in its last position. As a result the safety door is either completely locked or it can be closed and opened as often as required without activating the guard locking.

In this case (the guard locking is inactive and the power supply fails), BiState switches therefore ensure that there is no risk of persons being unintentionally trapped in the danger zone if the safety door closes.

In other words, there is no chance of getting locked in.

Principle of operation, Twin version

The switch has two actuating heads. They permit, depending on the series, the simultaneous monitoring, locking or unlocking of two movable guards.

The sectional drawings show the function of the Twin version:

1 One door closed

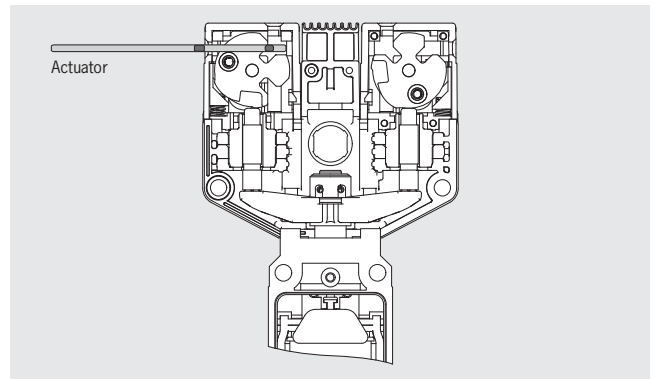

The first guard locking pin is released by inserting the actuator into the actuating head. Due to the rigid connection between the two plungers, a switching operation is not triggered by this action.

2 Both doors closed

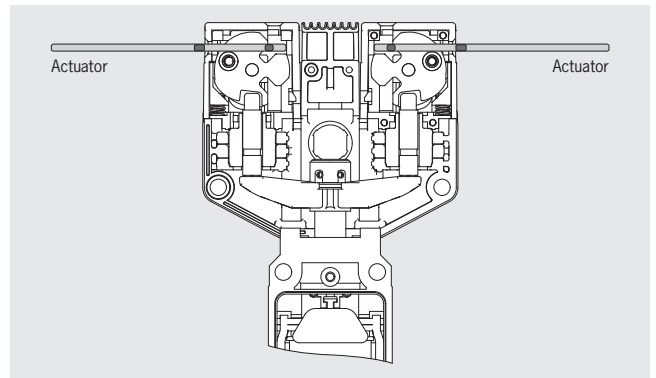

The second guard locking pin is released by inserting the actuator into the actuating head. The switching operation is triggered and the safety doors, depending on the version, monitored or locked.

Failsafe locking mechanism

The design feature of a guard locking which ensures that the locking mechanism (solenoid plunger) cannot go into the locking position if the guard is open is also referred to in DGUV Information 203-079 as failsafe locking mechanism.

The failsafe locking mechanism on an interlocking device with guard locking mechanically prevents the safety switch changing to the locked position with the guard open and therefore signaling a safe state.

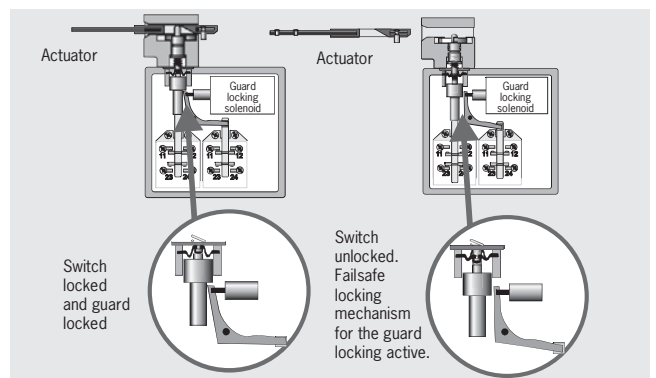

Selection table for safety switches NM type 1

Actuating element															
								Connection		Housing		Switching element			
WO	RB	KB	HB	AV	AL	AG	AK	M	SM4	Short	Long	1 contact	2 contacts	3 contacts	Page
												1 NC ⊖			14
													1 NC ⊖ +		14
													1 NO,		15
													2 NC ⊖		15
													2 NC ⊖ +		16
													1 NO,		16
													3 NC ⊖		17
															17
															18
															18
															18
															19
															19
															19
															20
															20

Safety switch NM..WO with rounded plunger



Approach direction



Vertical

Switching elements

- ▶ **ES01** Slow-action switching contact
1 NC ⊖
- ▶ **ES11** Slow-action switching contact
1 NC ⊕ + 1 NO
- ▶ **ES02** Slow-action switching contact
2 NC ⊖
- ▶ **ES12** Slow-action switching contact
2 NC ⊕ + 1 NO
- ▶ **ES03** Slow-action switching contact
3 NC ⊖

Cable entry M16 x 1.5
Short housing

Dimension drawing

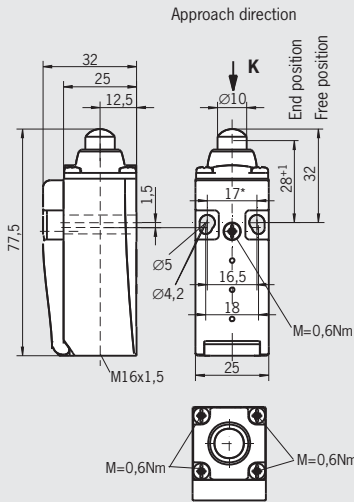

For cable glands, see page 108

Cable entry M16 x 1.5
Long housing

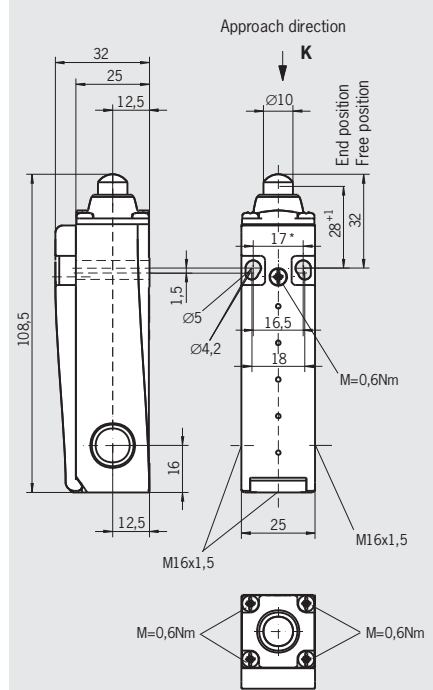

For cable glands, see page 108

Wiring diagrams Switch not actuated

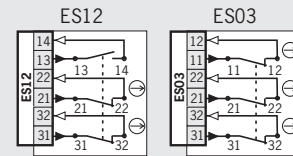
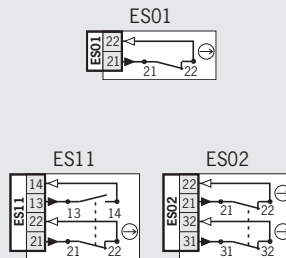

Ordering table

Series	Actuator	Connection	Housing	Switching element	Order no./item
NM	WO rounded plunger	Cable entry 1 x M16 x 1.5	Short 	01 1 NC ⊖	084495 NM01WOK-M
				11 1 NC ⊕ + 1 NO	095375 NM11WOK-MC2069
				02 2 NC ⊖	095374 NM02WOK-MC2069
		Cable entry 3 x M16 x 1.5	Long 	12 2 NC ⊕ + 1 NO	084498 NM12WOK-M
				03 3 NC ⊖	084499 NM03WOK-M

Safety switch NM..RB with roller plunger



Approach direction

Horizontal
Adjustable in 90° steps

Switching elements

- ▶ **ES01** Slow-action switching contact
1 NC ⊖
- ▶ **ES11** Slow-action switching contact
1 NC ⊖ + 1 NO
- ▶ **ES02** Slow-action switching contact
2 NC ⊖
- ▶ **ES12** Slow-action switching contact
2 NC ⊖ + 1 NO
- ▶ **ES03** Slow-action switching contact
3 NC ⊖

Cable entry M16 x 1.5
Short housing

Dimension drawing

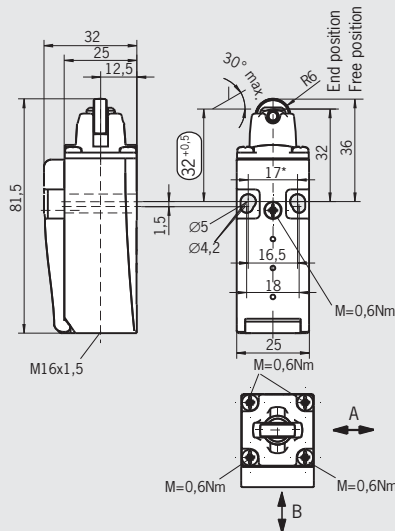

For cable glands, see page 108

Cable entry M16 x 1.5
Long housing

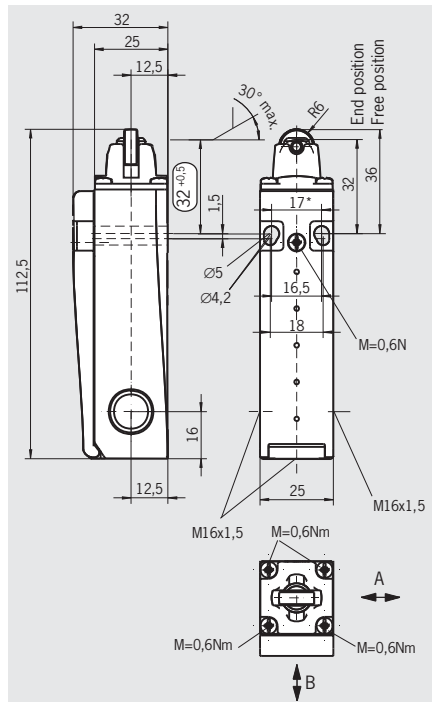

For cable glands, see page 108

Wiring diagrams Switch not actuated

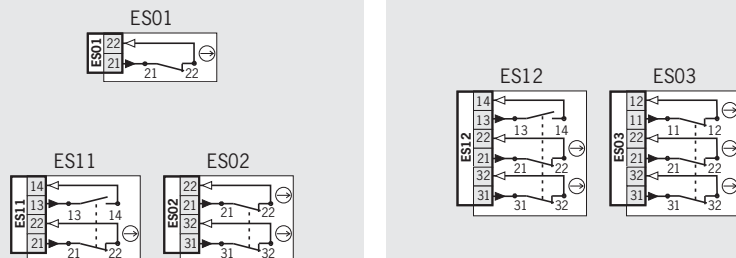

Ordering table

Series	Actuator	Connection	Housing	Switching element	Order no./item
NM	RB Roller plunger	Cable entry 1 x M16 x 1.5	Short 	01 1 NC ⊖	084515 NM01RBA-M
				11 1 NC ⊖ + 1 NO	095373 NM11RBA-MC2069
				02 2 NC ⊖	095372 NM02RBA-MC2069
		Cable entry 3 x M16 x 1.5	Long 	12 2 NC ⊖ + 1 NO	084518 NM12RBA-M
				03 3 NC ⊖	084519 NM03RBA-M

Safety switch NM..KB with roller arm



Approach direction



Horizontal
Adjustable in 90° steps

Switching elements

- ▶ **ES01** Slow-action switching contact
1 NC ⊖
- ▶ **ES11** Slow-action switching contact
1 NC ⊕ + 1 NO
- ▶ **ES02** Slow-action switching contact
2 NC ⊖
- ▶ **ES12** Slow-action switching contact
2 NC ⊕ + 1 NO
- ▶ **ES03** Slow-action switching contact
3 NC ⊖

Cable entry M16 x 1.5 Short housing

Dimension drawing

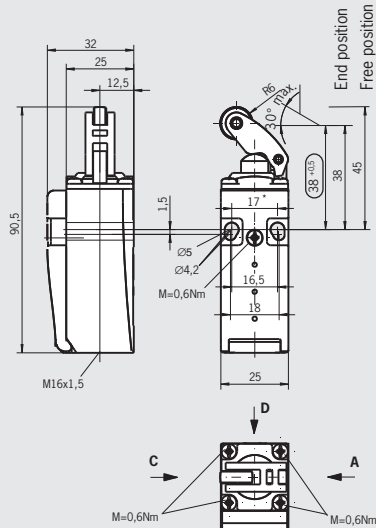

For cable glands, see page 108

Cable entry M16 x 1.5 Long housing

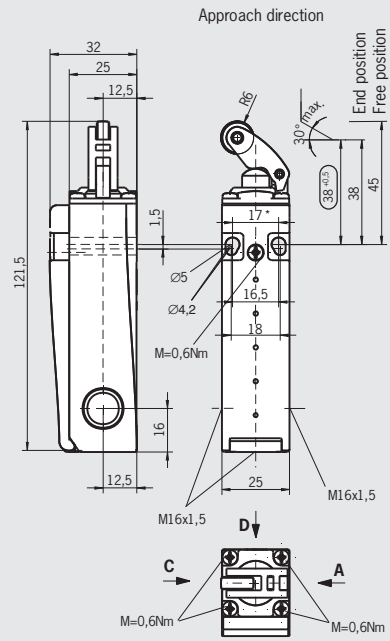

For cable glands, see page 108

Wiring diagrams Switch not actuated

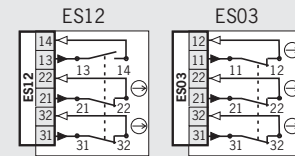
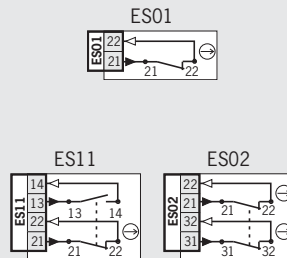

Ordering table

Series	Actuator	Connection	Housing	Switching element	Order no./item
NM	KB Roller arm	Cable entry 1 x M16 x 1.5	Short	01 1 NC ⊖	084522 NM01KBA-M
				11 1 NC ⊕ + 1 NO	095371 NM11KBA-MC2069
		Cable entry 3 x M16 x 1.5	Long	02 2 NC ⊖	095370 NM02KBA-MC2069
				12 2 NC ⊕ + 1 NO	084525 NM12KBA-M
			03 3 NC ⊖	084526 NM03KBA-M	

Safety switch NM..HB with lever arm



Approach direction

Horizontal
Adjustable in 90° steps

Switching elements

- ▶ **ES01** Slow-action switching contact
1 NC ⊖
- ▶ **ES11** Slow-action switching contact
1 NC ⊖ + 1 NO
- ▶ **ES02** Slow-action switching contact
2 NC ⊖
- ▶ **ES12** Slow-action switching contact
2 NC ⊖ + 1 NO
- ▶ **ES03** Slow-action switching contact
3 NC ⊖

Cable entry M16 x 1.5
Short housing

Dimension drawing

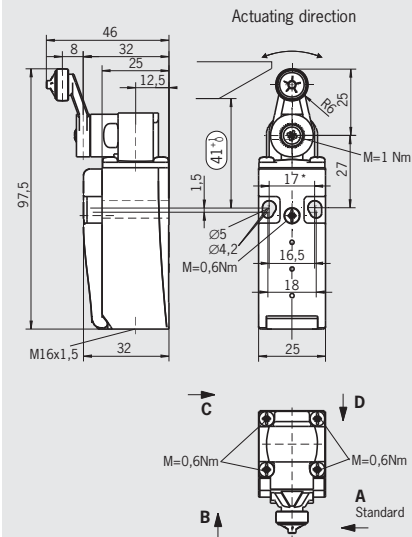

For cable glands, see page 108

Cable entry M16 x 1.5
Long housing

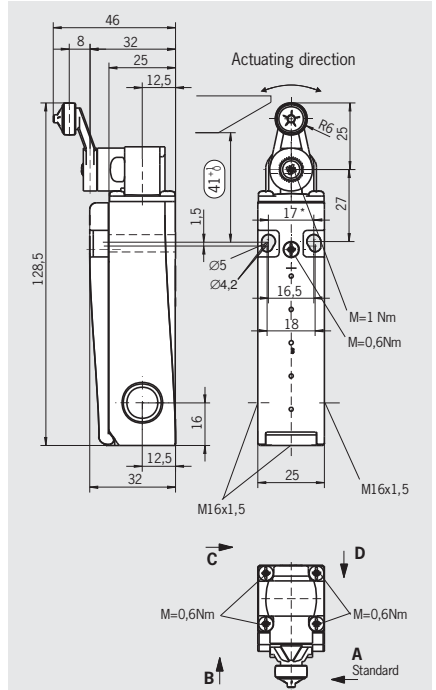

For cable glands, see page 108

Wiring diagrams Switch not actuated

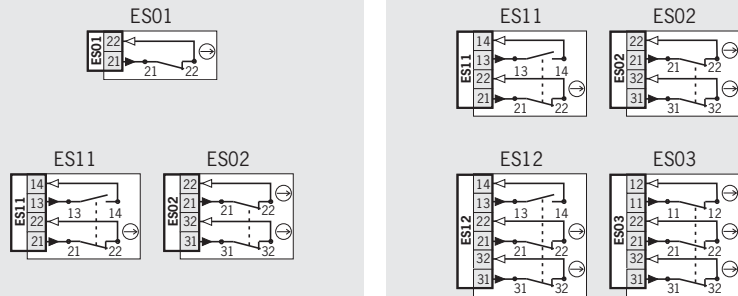

Ordering table

Series	Actuator	Connection	Housing	Switching element	Order no./item
NM	HB Lever arm	Cable entry 1 x M16 x 1.5	Short 	01 1 NC ⊖	084527 NM01HBA-M
				11 1 NC ⊖ + 1 NO	095369 NM11HBA-MC2069
				02 2 NC ⊖	095368 NM02HBA-MC2069
		Cable entry 3 x M16 x 1.5	Long 	12 2 NC ⊖ + 1 NO	084530 NM12HBA-M
				03 3 NC ⊖	084531 NM03HBA-M

Safety Switches Type 1, Plastic Housing

EUCHNER

Safety switch NM..AV/NM..AL



- ▶ Hinged actuator as solid shaft
- ▶ Shaft length 75 mm or 110 mm



Switching elements

- ▶ **ES01** Slow-action switching contact 1 NC ⊖
- ▶ **ES11** Slow-action switching contact 1 NC ⊖ + 1 NO
- ▶ **ES02** Slow-action switching contact 2 NC ⊖
- ▶ **ES12** Slow-action switching contact 2 NC ⊖ + 1 NO
- ▶ **ES03** Slow-action switching contact 3 NC ⊖

Cable entry M16 x 1.5 Short housing

Dimension drawing

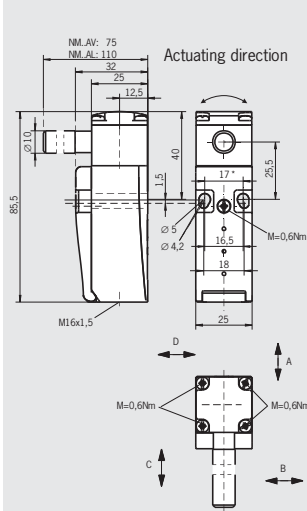

For cable glands, see page 108

Cable entry M16 x 1.5 Long housing

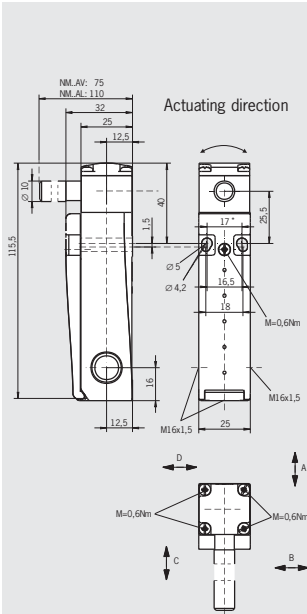

For cable glands, see page 108

Plug connector SM4 Plug M12, 4-pin, long housing

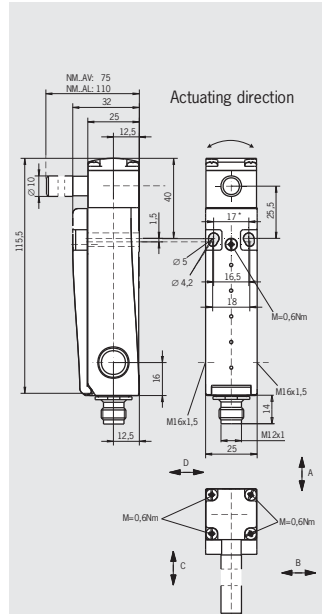

For plug connectors, see page 103

Wiring diagrams Switch not actuated

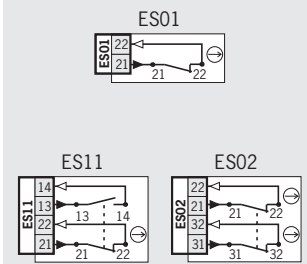

Ordering table

Series	Actuator	Connection	Housing	Switching element	Order no./item
NM	AV Hinged actuator Solid shaft Length 75 mm	Cable entry 1 x M16 x 1.5	Short	01 1 NC ⊖	084545 NM01AV-M
				11 1 NC ⊖ + 1 NO	095367 NM11AV-MC2069
				02 2 NC ⊖	095366 NM02AV-MC2069
	AL Hinged actuator Solid shaft Length 110 mm	Cable entry 3 x M16 x 1.5	Long	12 2 NC ⊖ + 1 NO	084548 NM12AV-M
				03 3 NC ⊖	084549 NM03AV-M
				12 2 NC ⊖ + 1 NO	079120 NM12AL-M
		SM4 Plug connector M12	Long	02 2 NC ⊖	093246 NM02AL-SM4

Safety switch NM..AG

- ▶ Hinged actuator as hollow shaft
- ▶ Internal diameter 10.2 mm



Switching elements

- ▶ **ES01** Slow-action switching contact 1 NC ⊖
- ▶ **ES11** Slow-action switching contact 1 NC ⊖ + 1 NO
- ▶ **ES02** Slow-action switching contact 2 NC ⊖
- ▶ **ES12** Slow-action switching contact 2 NC ⊖ + 1 NO
- ▶ **ES03** Slow-action switching contact 3 NC ⊖

Cable entry M16 x 1.5
Short housing

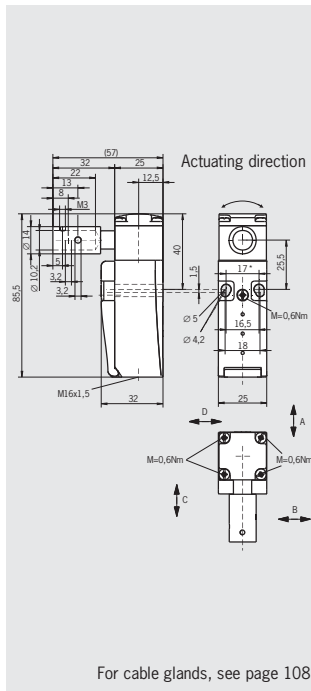

Cable entry M16 x 1.5
Long housing

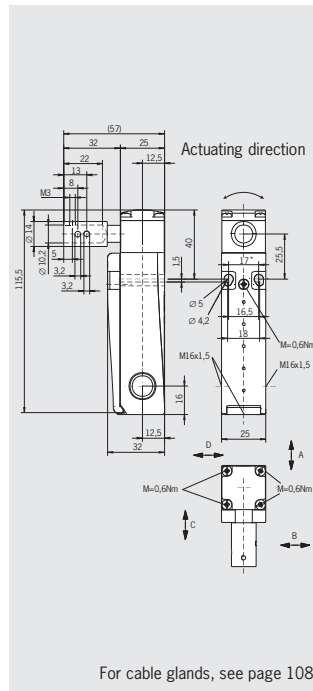

Plug connector SM4
Plug M12, 4-pin, long housing

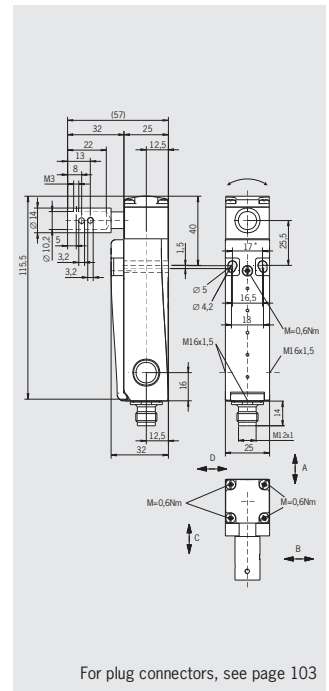

Wiring diagrams Switch not actuated

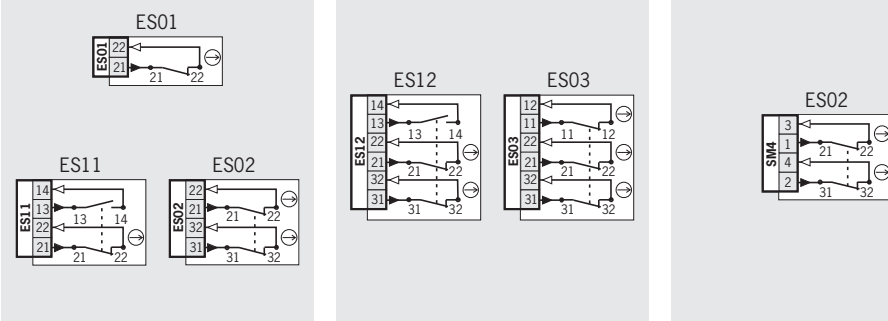

Ordering table

Series	Actuator	Connection	Housing	Switching element	Order no./item
NM	AG Hinged actuator Hollow shaft ∅ 10.2 mm	Cable entry 1 x M16 x 1.5		01 1 NC ⊖	084553 NM01AG-M
				11 1 NC ⊖ + 1 NO	095361 NM11AG-MC2069
				02 2 NC ⊖	095360 NM02AG-MC2069
		Cable entry 3 x M16 x 1.5		12 2 NC ⊖ + 1 NO	084556 NM12AG-M
				03 3 NC ⊖	084557 NM03AG-M
				02 2 NC ⊖	084565 NM02AG-SM4
SM4 Plug connector M12					

Safety switch NM..AK

- ▶ Hinged actuator as hollow shaft
- ▶ Internal diameter 8.2 mm



Switching elements

- ▶ **ES01** Slow-action switching contact
1 NC ⊖
- ▶ **ES11** Slow-action switching contact
1 NC ⊕ + 1 NO
- ▶ **ES02** Slow-action switching contact
2 NC ⊖
- ▶ **ES12** Slow-action switching contact
2 NC ⊕ + 1 NO
- ▶ **ES03** Slow-action switching contact
3 NC ⊖

Cable entry M16 x 1.5 Short housing

Dimension drawing

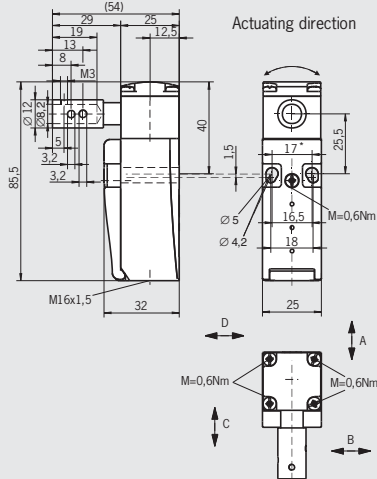

For cable glands, see page 108

Cable entry M16 x 1.5 Long housing

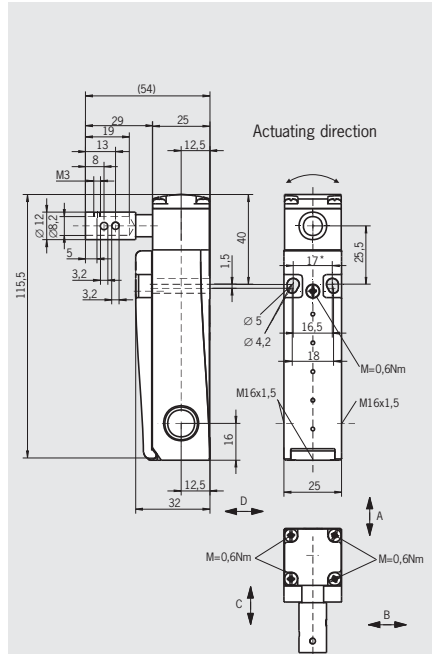

For cable glands, see page 108

Wiring diagrams Switch not actuated

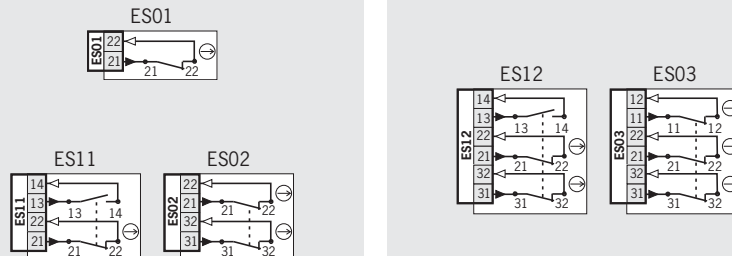

Ordering table

Series	Actuator	Connection	Housing	Switching element	Order no./item
NM	AK Hinged actuator Hollow shaft ∅ 8.2 mm	Cable entry 1 x M16 x 1.5	Short 	01 1 NC ⊖	084559 NM01AK-M
				11 1 NC ⊕ + 1 NO	095363 NM11AK-MC2069
		Cable entry 3 x M16 x 1.5	Long 	02 2 NC ⊖	095362 NM02AK-MC2069
				12 2 NC ⊕ + 1 NO	084562 NM12AK-M
				03 3 NC ⊖	084563 NM03AK-M

Safety switch NM..VZ

- ▶ Cable entry M16 x 1.5
- ▶ Plug connector M12 optional



Approach direction

Horizontally and vertically adjustable in 90° steps



Switching elements

- ▶ **ES01** Slow-action switching contact
1 NC ⊖
- ▶ **ES11** Slow-action switching contact
1 NC ⊖ + 1 NO
- ▶ **ES02** Slow-action switching contact
2 NC ⊖
- ▶ **ES12** Slow-action switching contact
2 NC ⊖ + 1 NO
- ▶ **ES03** Slow-action switching contact
3 NC ⊖

Cable entry M16 x 1.5 Short housing

Dimension drawing

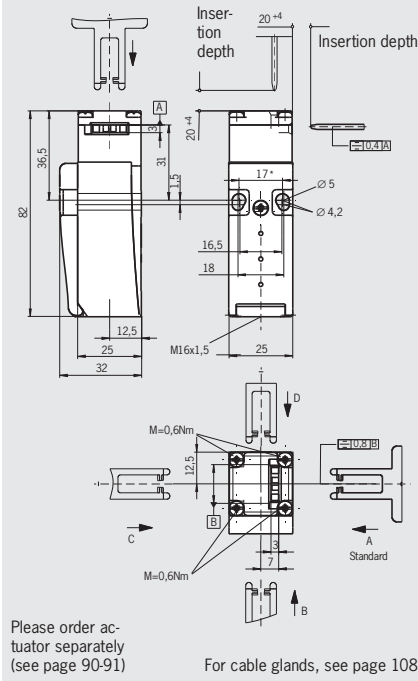

Cable entry M16 x 1.5 Long housing

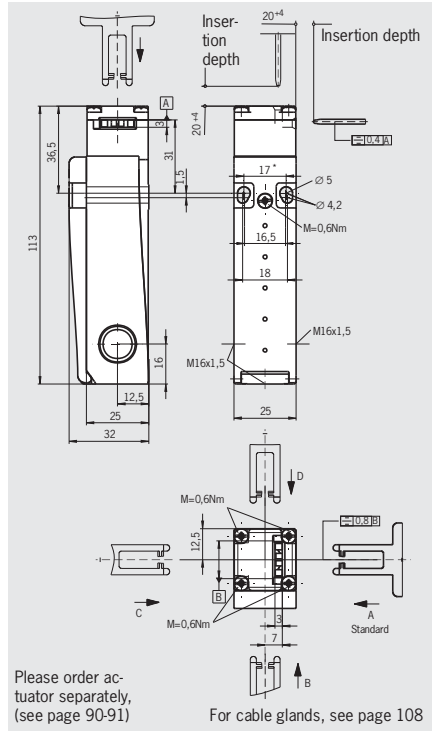

Wiring diagrams actuator inserted

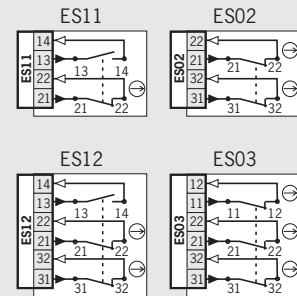
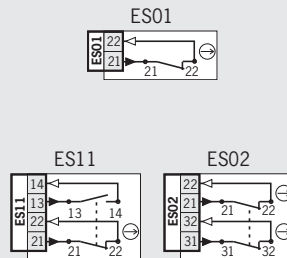

Ordering table

Series	Actuator	Connection	Housing	Switching element	Order no./item
NM	VZ Separate actuator	Cable entry 1 x M16 x 1.5		01 1 NC ⊖	084451 NMO1VZA-M
				11 1 NC ⊖ + 1 NO	094471 NM11VZA-MC2069
				02 2 NC ⊖	094470 NMO2VZA-MC2069
		Cable entry 3 x M16 x 1.5		11 1 NC ⊖ + 1 NO	084452 NM11VZA-M
				02 2 NC ⊖	084453 NMO2VZA-M
				12 2 NC ⊖ + 1 NO	084454 NM12VZA-M
				03 3 NC ⊖	084455 NMO3VZA-M



Safety switch NP

- ▶ Mounting to DIN EN 50047
- ▶ Cable entry M20 x 1.5
- ▶ Plug connector optional



Approach direction



Horizontally and vertically adjustable in 90° steps

Switching elements

- ▶ **618** Slow-action switching contact
1 NC ⊖
- ▶ **628** Slow-action switching contact
1 NC ⊖ + 1 NO
- ▶ **638** Slow-action switching contact
2 NC ⊖
- ▶ **648** Slow-action switching contact
2 NC ⊖ + 1 NO

Cable entry M20 x 1.5

Dimension drawing

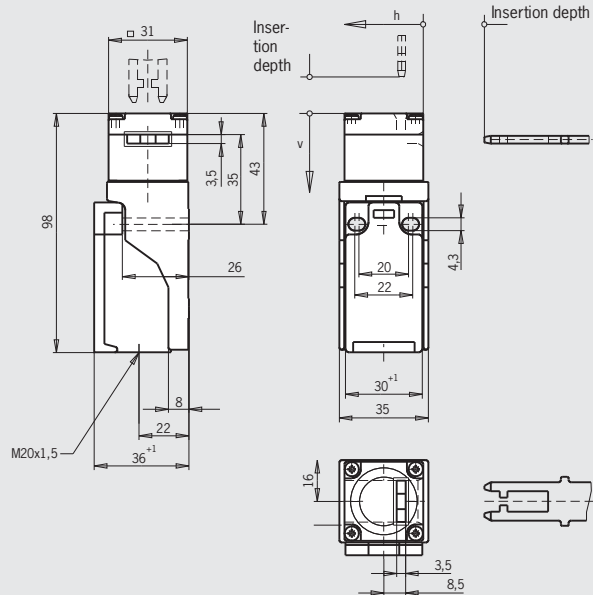

Please order actuator separately (see page 92-95)

For cable glands, see page 108

Wiring diagrams actuator inserted

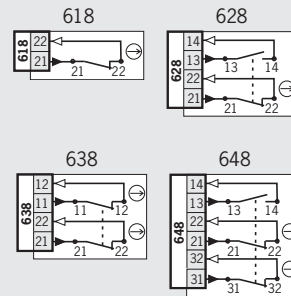

Ordering table

Series	Installation	Connection	Switching element	Order no./item
NP	AS According to DIN EN 50047	1 Cable entry 1 x M20 x 1.5	618 1 NC ⊖	083685 NP1-618AS-M
			628 1 NC ⊖ + 1 NO	083688 NP1-628AS-M
			638 2 NC ⊖	083691 NP1-638AS-M
			648 ¹⁾ 2 NC ⊖ + 1 NO	082280¹⁾ NP1-648AS-M

1) No CE approval



Plug connector SM4 Plug M12, 4-pin

Plug connector SR6 6-pin + PE

Dimension drawing

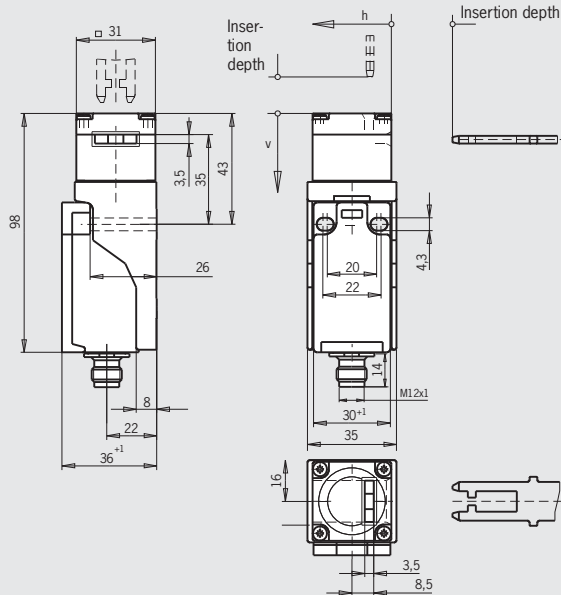

Please order actuator separately (see page 92-95)

For plug connectors, see page 103

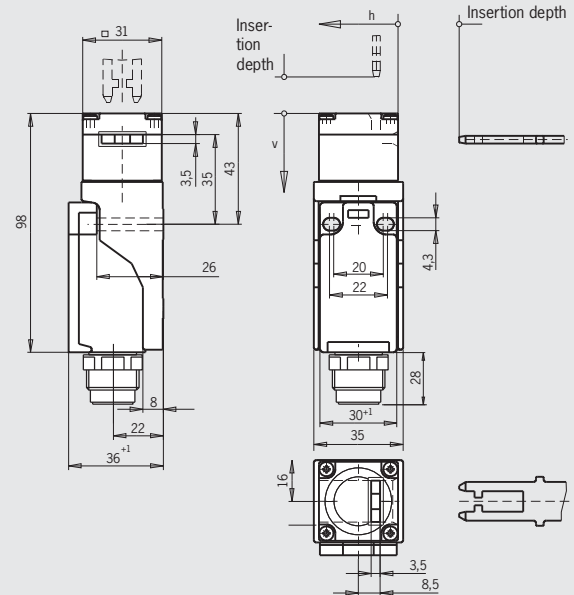

Please order actuator separately (see page 92-95)

For plug connectors, see page 104

Wiring diagrams actuator inserted

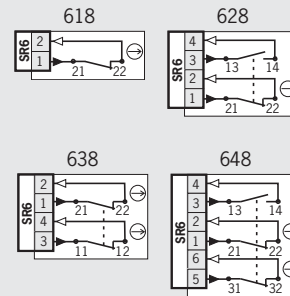
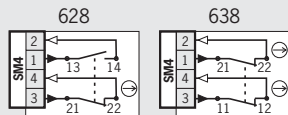

Ordering table

Series	Installation	Connection	Switching element	Order no./item
NP	AS According to DIN EN 50047	3 SM4 Plug connector M12	628 1 NC \rightarrow + 1 NO	098633 NP3-628AS
			638 2 NC \rightarrow	084400 NP3-638AS
		2 Plug connector SR6	618 1 NC \rightarrow	059445 NP2-618AS
			628 1 NC \rightarrow + 1 NO	059447 NP2-628AS
			638 2 NC \rightarrow	059449 NP2-638AS
			648 2 NC \rightarrow + 1 NO	088924 NP2-648AS



Safety switch NP

- ▶ Mounting with 40 mm spacing
- ▶ Cable entry M20 x 1.5
- ▶ Plug connector optional



Approach direction

Horizontally and vertically adjustable in 90° steps

Switching elements

- ▶ **618** Slow-action switching contact
1 NC ⊖
- ▶ **628** Slow-action switching contact
1 NC ⊖ + 1 NO
- ▶ **638** Slow-action switching contact
2 NC ⊖
- ▶ **648** Slow-action switching contact
2 NC ⊖ + 1 NO

Cable entry M20 x 1.5

Dimension drawing

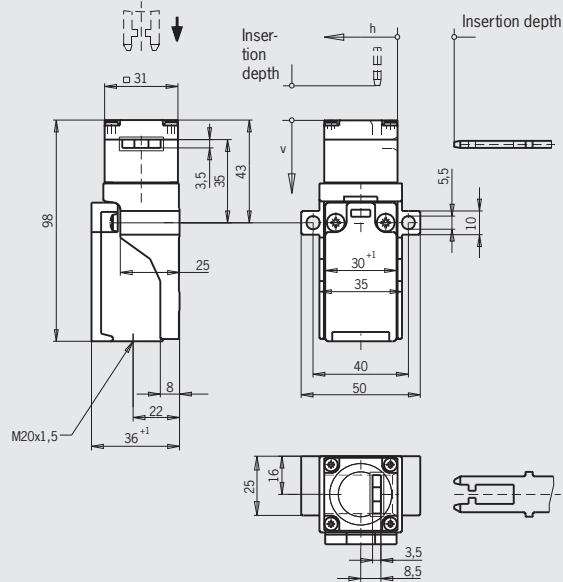

Please order actuator separately (see page 92-95)

For cable glands, see page 108

Wiring diagrams actuator inserted

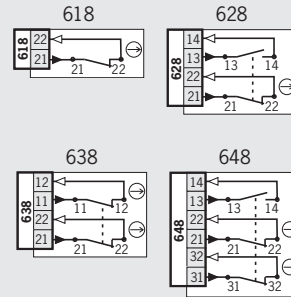

Ordering table

Series	Installation	Connection	Switching element	Order no./item
NP	AB with 40 mm spacing	1 Cable entry 1 x M20 x 1.5	618 1 NC ⊖	083680 NP1-618AB-M
			628 1 NC ⊖ + 1 NO	083686 NP1-628AB-M
			638 2 NC ⊖	083690 NP1-638AB-M
			648 ¹⁾ 2 NC ⊖ + 1 NO	082276 ¹⁾ NP1-648AB-M

1) No CE approval



Plug connector SM4 Plug M12, 4-pin

Plug connector SR6 6-pin + PE

Dimension drawing

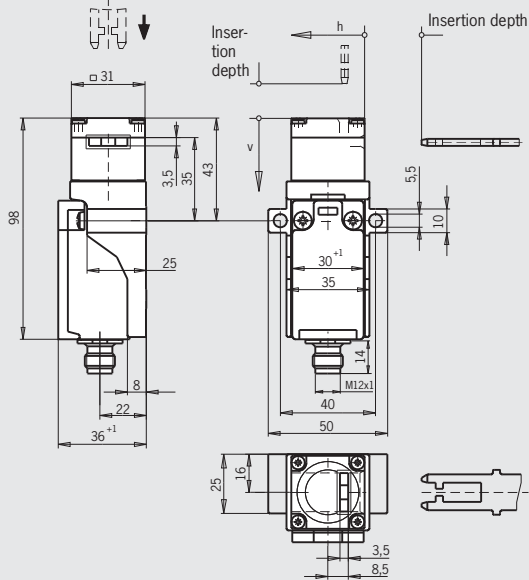

Please order actuator separately (see page 92-95)

For plug connectors, see page 103

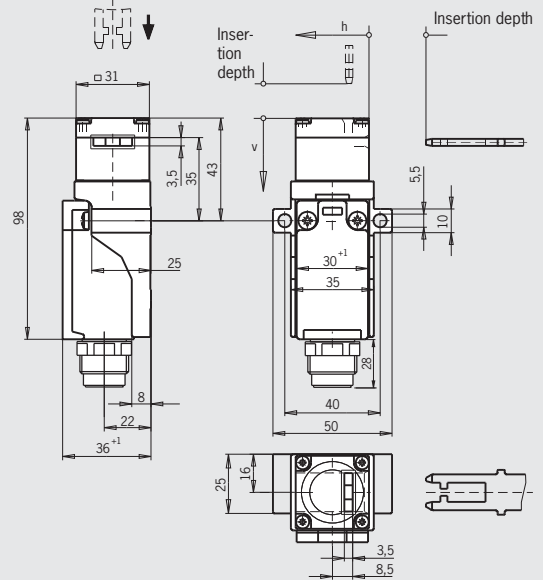

Please order actuator separately (see page 92-95)

For plug connectors, see page 104

Wiring diagrams actuator inserted

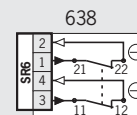
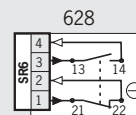
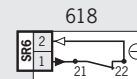
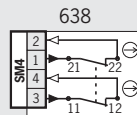

Ordering table

Series	Installation	Connection	Switching element	Order no./item
NP	AB with 40 mm spacing	3 SM4 Plug connector M12	638 2 NC ⊖	094509 NP3-638AB
		2 Plug connector SR6	618 1 NC ⊖	059446 NP2-618AB
			628 1 NC ⊖ + 1 NO	059448 NP2-628AB
			638 2 NC ⊖	059450 NP2-638AB

Selection table for safety switches GP

Connection				
M				Thread M20 x 1.5 for cable gland
	SR11			Plug connector, 11-pin + PE
		Switching element		
		2 contacts		1 NC ⊖ + 1 NO, 2 NC ⊖
			4 contacts	2 NC ⊖ + 2 NO, 3 NC ⊖ + 1 NO, 4 NC ⊖



Connection		Switching element		Page
M	SR11	2 contacts	4 contacts	
●		●	●	32
	●		●	33



Safety switch GP

- ▶ Cable entry M20 x 1.5
- ▶ Plug connector optional



Approach direction



Horizontally and vertically adjustable in 90° steps

Switching elements

- ▶ **528** Slow-action switching contact
1 NC \ominus + 1 NO
- ▶ **538** Slow-action switching contact
2 NC \ominus
- ▶ **2121** Slow-action switching contact
4 NC \ominus
- ▶ **2131** Slow-action switching contact
3 NC \ominus + 1 NO
- ▶ **3131** Slow-action switching contact
2 NC \ominus + 2 NO

Cable entry M20 x 1.5

Dimension drawing

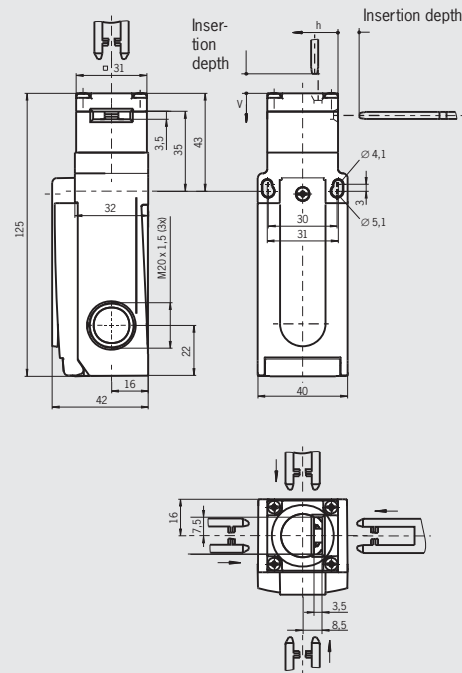

Please order actuator separately (see page 92-95)

For cable glands, see page 108

Wiring diagrams actuator inserted

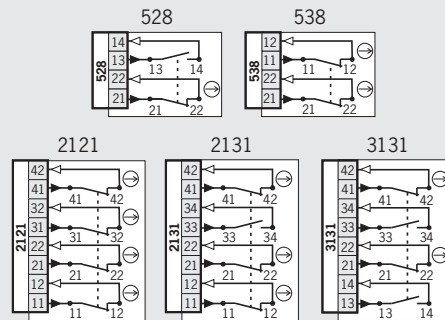

Ordering table

Series	Connection	Switching element	Order no./item
GP	1 Cable entry 3 x M20 x 1.5	528 1 NC \ominus + 1 NO	089725 GP1-528A-M
		538 2 NC \ominus	090250 GP1-538A-M
		2121 4 NC \ominus	090252 GP1-2121A-M
		2131 3 NC \ominus + 1 NO	090255 GP1-2131A-M
		3131 2 NC \ominus + 2 NO	090258 GP1-3131A-M



Plug connector SR11 11-pin + PE

Dimension drawing

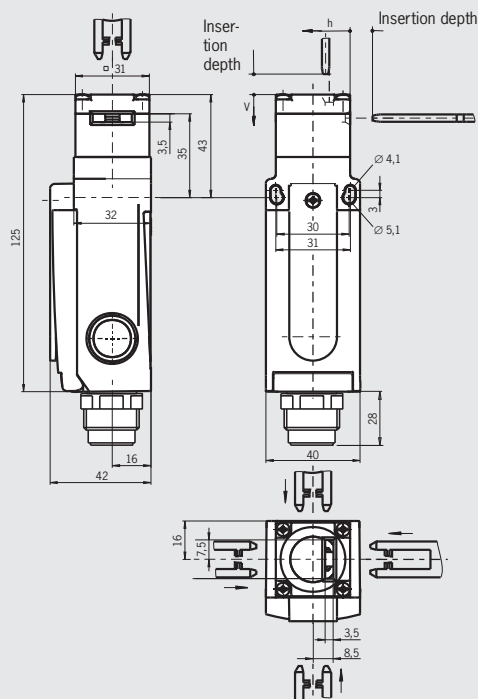

Please order actuator separately (see page 92-95)

For plug connectors, see page 104

Wiring diagrams actuator inserted

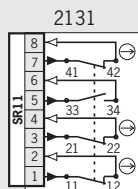

Ordering table

Series	Connection	Switching element	Order no./item
GP	2 Plug connector SR11	2131 3 NC ⊕ + 1 NO	096227 GP2-2131ASR11

For technical data, see page 121

Selection table for safety switches SGP

Version						
Standard		TW				
		Mounting to DIN EN 50047				
		Mounting with 40 mm spacing				
Connection						
		M		SR6		SR11
		Thread M20 x 1.5 for cable gland		Plug connector SR6, 6-pin + PE		Plug connector SR11, 11-pin + PE
Switching element						
		4 contacts				
		2 NC ⊖ + 2 NO,				
		3 NC ⊖ + 1 NO,				
		4 NC ⊖				
Version		Connection			Switching element	Page
Standard	TW	M	SR6	SR11	4 contacts	
●		●			●	36
●			●	●	●	37
	●	●			●	38

Safety switch SGP

- ▶ Actuating head made of metal
- ▶ Cable entry M20 x 1.5
- ▶ Plug connector optional



Approach direction



Horizontally and vertically adjustable in 90° steps

Switching elements

- ▶ **538** Slow-action switching contact
2 NC ⊖
- ▶ **2121** Slow-action switching contact
4 NC ⊖
- ▶ **2131** Slow-action switching contact
3 NC ⊖ + 1 NO
- ▶ **3131** Slow-action switching contact
2 NC ⊖ + 2 NO

Cable entry M20 x 1.5

Dimension drawing

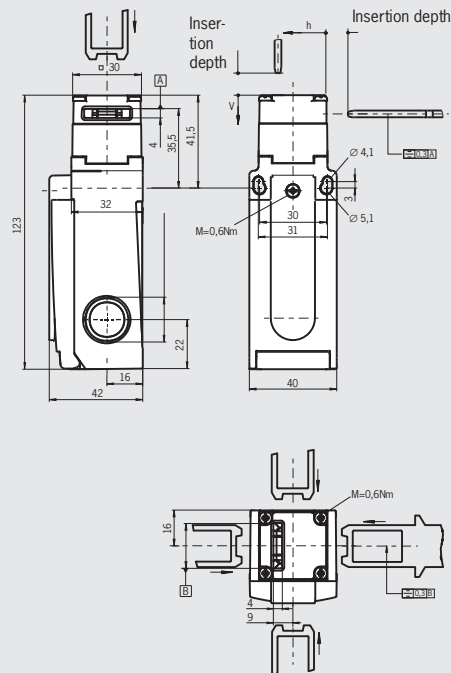

Please order actuator separately (see page 96-99)

For cable glands, see page 108

Wiring diagrams actuator inserted

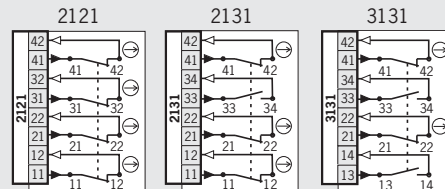

Ordering table

Series	Connection	Switching element	Order no./item
SGP	1 Cable entry 3 x M20 x 1.5	2121 4 NC ⊖	097705 SGP1E-2121A-M
		2131 3 NC ⊖ + 1 NO	097706 SGP1E-2131A-M
		3131 2 NC ⊖ + 2 NO	097707 SGP1E-3131A-M



Plug connector SR6 6-pin + PE

Plug connector SR11 11-pin + PE

Dimension drawing

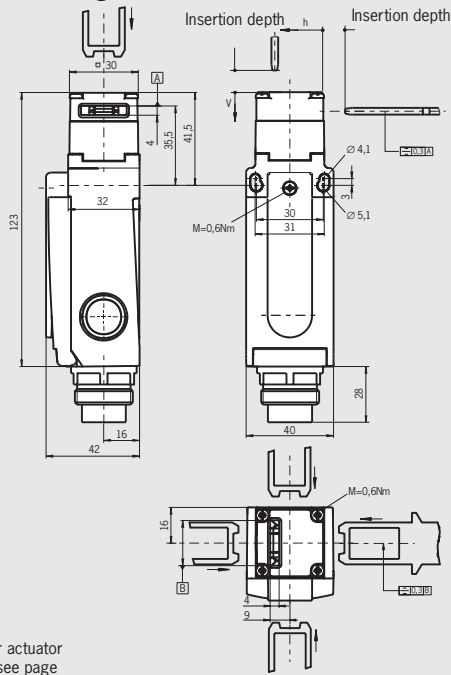

Please order actuator separately (see page 96-99)

For plug connectors, see page 104

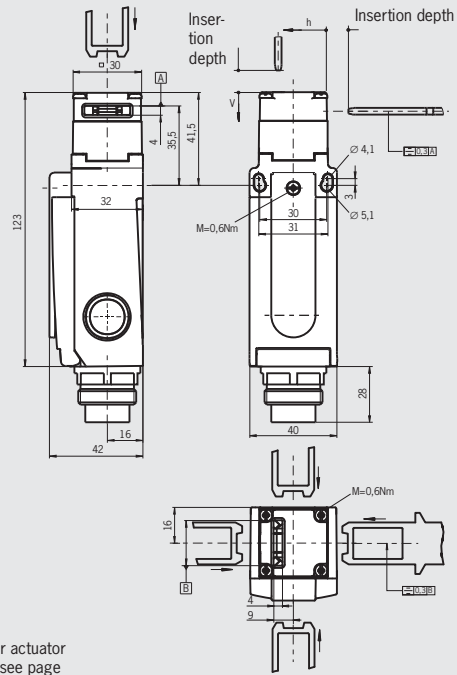

Please order actuator separately (see page 96-99)

For plug connectors, see page 104

Wiring diagrams actuator inserted

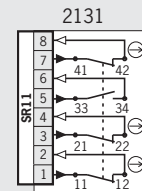
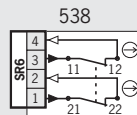

Ordering table

Series	Connection	Switching element	Order no./item
SGP	2 Plug connector SR6	538 2 NC ⊖	104022 SGP2E-538ASR6
	2 Plug connector SR11	2131 3 NC ⊖ + 1 NO	099084 SGP2E-2131ASR11



Safety switch SGP-TW

- ▶ Actuating heads made of metal
- ▶ Simultaneous monitoring of two safety doors
- ▶ Lock function with state indication (optional)
- ▶ Cable entry M20 x 1.5



Approach direction



Horizontally and vertically adjustable in 90° steps

Switching elements

- ▶ **2131** Slow-action switching contact
3 NC \ominus + 1 NO

Cable entry M20 x 1.5

Dimension drawing

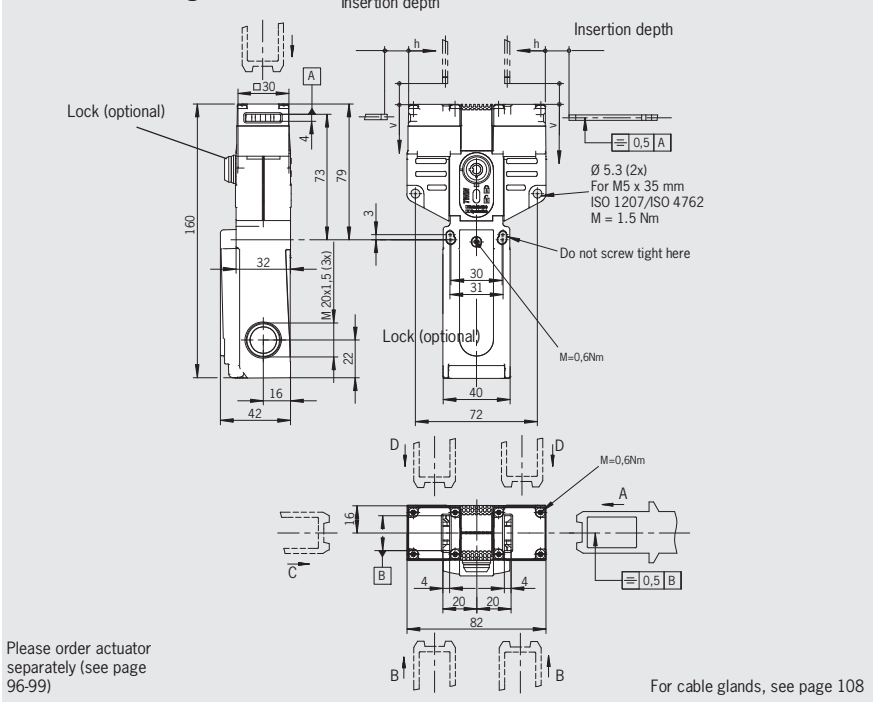

Wiring diagrams actuator inserted

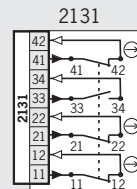

Ordering table

Series	Connection	Switching element	Version	Order no./item
SGP-TW	1 Cable entry 3 x M20 x 1.5	2131 3 NC \ominus + 1 NO	Without lock function	100809 SGP-TW-1E-2131AC-M
			Lock function with state indication	099900 SGP-TW-1E-2131AC-M-S1

Selection table for safety switches SGA

Version						
Standard		One actuating head made of metal				
Connection						
M		SR11		M23 (RC18)		
				Thread M20x1.5 for cable glands		
				Plug connector 11-pin + PE		
				Plug connector 18-pin + PE		
Switching element						
				2 contacts		2 NC ⊖
						3 NC ⊖ + 1 NO,
				4 contacts		4 NC ⊖
Version Standard	M	Connection		Switching element		Page
		SR11	M23 (RC18)	2 contacts	4 contacts	
●	●				●	40
●		●			●	41
●			●		●	42



Safety switch SGA

- ▶ Metal housing with metal actuating head
- ▶ Cable entry M20 x 1.5
- ▶ Plug connector optional



Approach direction

Horizontally and vertically adjustable in 90° steps

Switching elements

- ▶ **2121** Slow-action switching contact
4 NC ⊖
- ▶ **2131** Slow-action switching contact
3 NC ⊖ + 1 NO

Cable entry M20 x 1.5

Dimension drawing

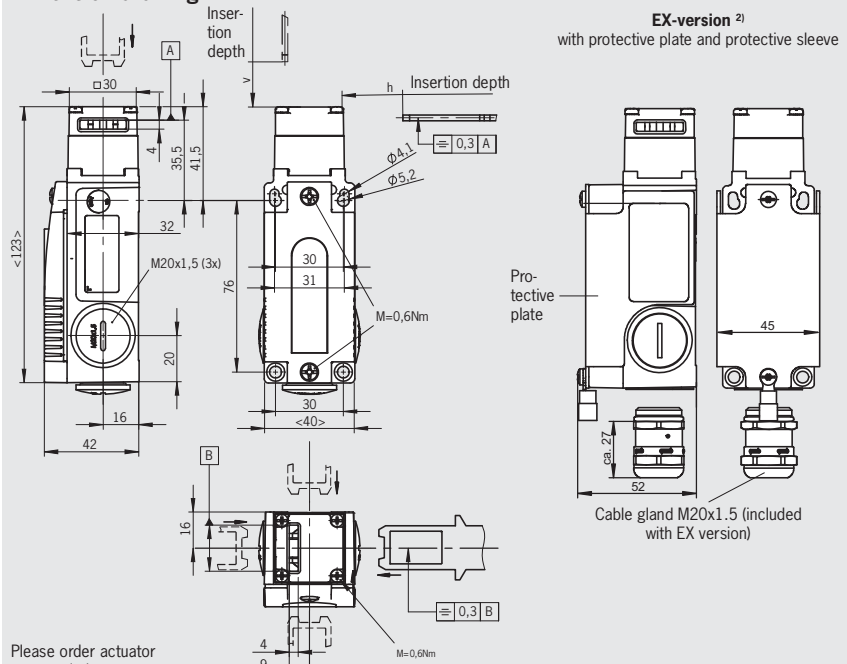

For cable glands, see page 108

Wiring diagrams actuator inserted

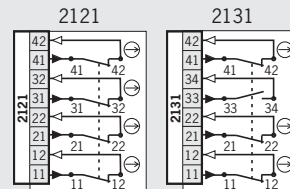

Ordering table

Series	Connection	Switching element	Version	Order no./item
SGA	1 Cable entry 3 x M20 x 1.5	2121 4 NC ⊖		103725 SGA1A-2121A-M
		2131 3 NC ⊖ + 1 NO		106307 SGA1A-2131A-M
			ATEX incl. cable gland	123460 ¹⁾ SGA1A-2131A-M-EX

1) ⊕ II 3 G Ex nRB T5 Gc / ⊕ II 3 D Ex tc IIIC T90° Dc X



Safety switch SGA

- ▶ Metal housing with metal actuating head
- ▶ 2 illuminated pushbuttons
- ▶ Plug connector M23 (RC18)



Approach direction



Horizontally and vertically adjustable in 90° steps

Switching elements

- ▶ **2121** Slow-action switching contact 4 NC ⊖

Plug connector M23 (RC18)

18-pin + PE

Dimension drawing

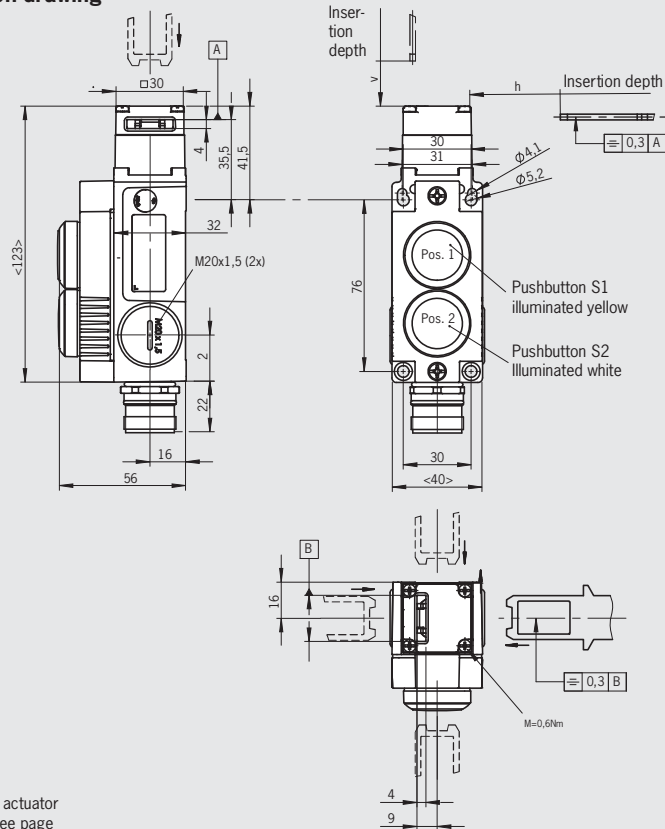

Please order actuator separately (see page 96-99)

For plug connectors, see page 105-106

Wiring diagrams actuator inserted

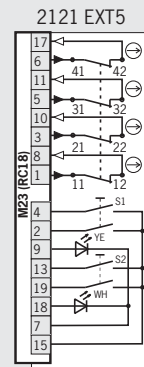

Ordering table

Series	Connection	Switching element	Version	Order no./item
SGA	2 Plug connector M23 (RC18)	2121 4 NC ⊖	Pos. 1: yellow pushbutton Pos. 2: white pushbutton	104012 SGA2A-2121ARC18-EXT5

Selection table for safety switches TP with guard locking and guard locking monitoring

Release feature													
HE		Mechanical release on the front											
FE		Escape release on the rear											
Door monitoring													
TP1/2		Without door monitoring contact											
TP3/4		With door monitoring contact											
TP5/6		With door unlock request contact											
Overtravel													
A		Increased horizontal overtravel											
CI		Increased horizontal and vertical overtravel											
Connection													
M		Thread M20x1.5 for cable gland											
SR6		Plug connector, 6-pin + PE											
SM8		Plug connector M12, 8-pin											
SR11		Plug connector, 11-pin + PE											
BHA12		Plug connector, 12-pin											
M23 (RC18)		Plug connector, 18-pin + PE											
Release feature		Door monitoring			Overtravel		Connection						Page
HE	FE	TP1/2	TP3/4	TP5/6	A	CI	M	SR6	SM8	SR11	BHA12	M23 (RC18)	
●		●			●		●						44
●		●			●			●		●			45
●		●				●	●	●					46
●		●				●	●	●		●			47
●			●		●		●						48 - 51
●			●		●			●	●				52
●			●		●					●			53
●			●			●	●	●					54
●			●			●	●	●		●			55
●				●	●		●			●			56
●	●		●		●		●			●			57
●			●		●						●	●	58
●	●		●		●							●	59

Safety switch TP with guard locking and guard locking monitoring



- ▶ Mechanical release on the front
- ▶ Without door monitoring contact
- ▶ Increased horizontal overtravel



Approach direction

Horizontally and vertically adjustable in 90° steps
Increased overtravel for horizontal approach direction.

Mechanical release

Is used for releasing the guard locking with the aid of a tool. To protect against tampering, the mechanical release is sealed with sealing lacquer.

Solenoid operating voltage

- ▶ AC/DC 24 V +10%, -15%
- ▶ AC 110 V +10%, -15%
- ▶ AC 230 V +10%, -15%

LED function display (optional)

A function display (2 LEDs, red and green) is available for the following voltage ranges:

- ▶ AC/DC 24 V +10%, -15%

Guard locking types

TP1 Closed-circuit current principle, guard locking by spring force. Release by applying voltage to the guard locking solenoid.

TP2 Open-circuit current principle, guard locking by applying voltage to the guard locking solenoid. Release by spring force.

Switching elements

- ▶ **528** Slow-action switching contact
1 NC ⊕ + 1 NO
- ▶ **538** Slow-action switching contact
2 NC ⊕
- ▶ **2121** Slow-action switching contact
4 NC ⊕
- ▶ **4131** Slow-action switching contact
2 NC ⊕ + 2 NO

Cable entry M20 x 1.5

Dimension drawing

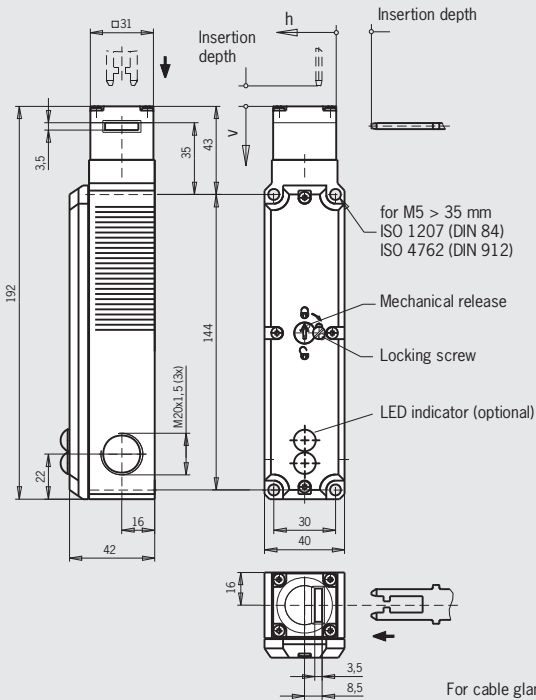

Please order actuator separately (see page 92-95)

For cable glands, see page 108

Wiring diagrams actuator inserted and locked

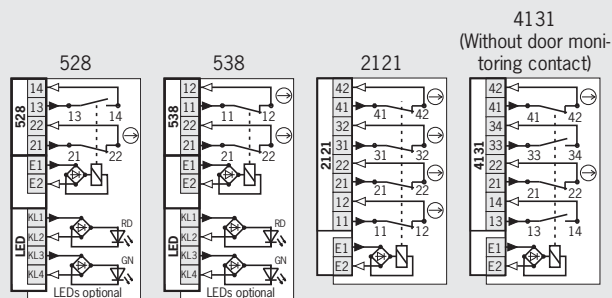

For switching functions, see technical data on page 135

Ordering table

Series	Connection	Guard locking	Switching element	Version	Solenoid operating voltage		
					AC/DC 24 V	AC 110 V	AC 230 V
TP	M Cable entry 3 x M20 x 1.5	1 Mechanical	528 1 NC ⊕ + 1 NO		084295 TP1-528A024M	084300 TP1-528A110M	084304 TP1-528A230M
			528 1 NC ⊕ + 1 NO	024L LED indicator AC/DC 24 V	094058 TP1-528A024L024M	-	-
			538 2 NC ⊕		084310 TP1-538A024M	084315 TP1-538A110M	084320 TP1-538A230M
			538 2 NC ⊕	024L LED indicator AC/DC 24 V	093459 TP1-538A024L024M	-	-
			4131 2 NC ⊕ + 2 NO		084115 TP1-4131A024M	084116 TP1-4131A110M	084117 TP1-4131A230M
			4131 2 NC ⊕ + 2 NO		084125 TP2-4131A024M	084126 TP2-4131A110M	084128 TP2-4131A230M
		2 Electrical	528 1 NC ⊕ + 1 NO		084325 TP2-528A024M	084330 TP2-528A110M	084332 TP2-528A230M
			538 2 NC ⊕		084333 TP2-538A024M	084334 TP2-538A110M	084335 TP2-538A230M
			2121 4 NC ⊕		096528 TP2-2121A024M	-	-
			4131 2 NC ⊕ + 2 NO		084125 TP2-4131A024M	084126 TP2-4131A110M	084128 TP2-4131A230M
			4131 2 NC ⊕ + 2 NO		084125 TP2-4131A024M	084126 TP2-4131A110M	084128 TP2-4131A230M
			4131 2 NC ⊕ + 2 NO		084125 TP2-4131A024M	084126 TP2-4131A110M	084128 TP2-4131A230M

1) With cable entry M, DC 24 V / AC 110 V



Plug connector SR6 6-pin + PE

Plug connector SR11 11-pin + PE

Dimension drawing

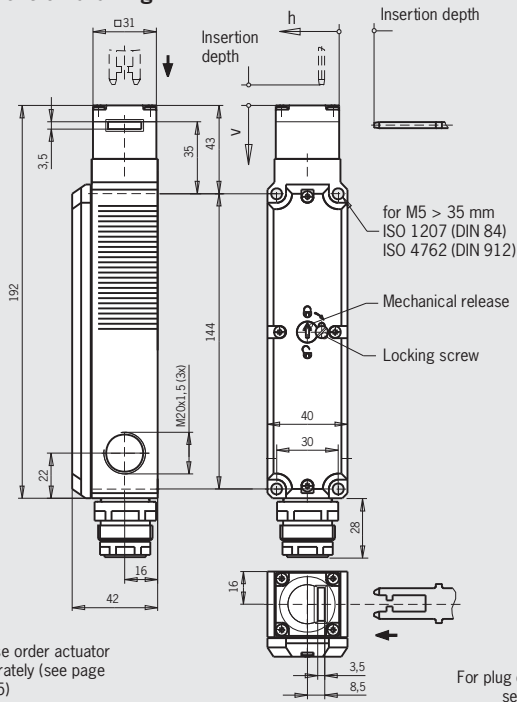

Please order actuator separately (see page 92-95)

For plug connectors, see page 104

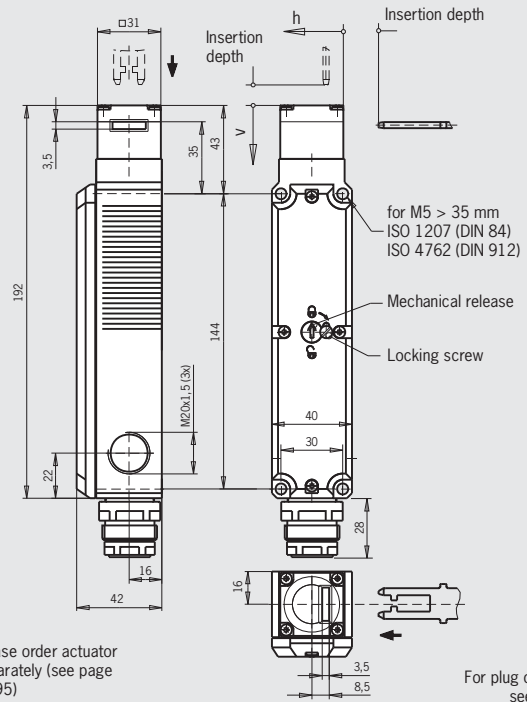

Please order actuator separately (see page 92-95)

For plug connectors, see page 104

Wiring diagrams actuator inserted and locked

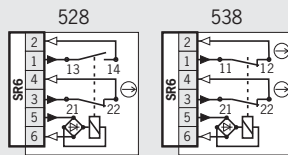

For switching functions, see technical data on page 135

4131 (Without door monitoring contact)

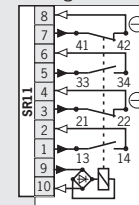

For switching functions, see technical data on page 135

Ordering table

Series	Connection	Guard locking	Switching element	Solenoid operating voltage		
				AC/DC 24 V	AC 110 V	AC 230 V
TP	SR6 Plug connector	1 Mechanical	528 1 NC ⊖ + 1 NO	087431 TP1-528A024SR6	087435 TP1-528A110SR6	087438 TP1-528A230SR6
			538 2 NC ⊖	087433 TP1-538A024SR6	087436 TP1-538A110SR6	087439 TP1-538A230SR6
		2 Electrical	528 1 NC ⊖ + 1 NO	087441 TP2-528A024SR6	087444 TP2-528A110SR6	087448 TP2-528A230SR6
			538 2 NC ⊖	087442 TP2-538A024SR6	087446 TP2-538A110SR6	087449 TP2-538A230SR6
	SR11 Plug connector	1 Mechanical	4131 2 NC ⊖ + 2 NO	088202 TP1-4131A024SR11	-	-
		2 Electrical	4131 2 NC ⊖ + 2 NO	088203 TP2-4131A024SR11	-	-

2) Only with solenoid operating voltage AC/DC 24 V

Safety switch TP with guard locking and guard locking monitoring



- ▶ Mechanical release on the front
- ▶ Without door monitoring contact
- ▶ Increased overtravel for horizontal and vertical approach direction.



Approach direction



Horizontally and vertically adjustable in 90° steps
Increased overtravel for horizontal and vertical approach direction.

Mechanical release

Is used for releasing the guard locking with the aid of a tool. To protect against tampering, the mechanical release is sealed with sealing lacquer.

Solenoid operating voltage

- ▶ AC/DC 24 V +10%, -15%
- ▶ AC 110 V +10%, -15%
- ▶ AC 230 V +10%, -15%

Guard locking types

- TP1** Closed-circuit current principle, guard locking by spring force. Release by applying voltage to the guard locking solenoid.
- TP2** Open-circuit current principle, guard locking by applying voltage to the guard locking solenoid. Release by spring force.

Switching elements

- ▶ **528** Slow-action switching contact
1 NC ⊕ + 1 NO
- ▶ **538** Slow-action switching contact
2 NC ⊕
- ▶ **4131** Slow-action switching contact
2 NC ⊕ + 2 NO

Ordering table

Series	Connection	Guard locking	Switching element	Solenoid operating voltage		
				AC/DC 24 V	AC 110 V	AC 230 V
TP	M Cable entry 3 x M20 x 1.5	1 Mechanical	528 1 NC ⊕ + 1 NO	084342 TP1-528K024M	-	-
			538 2 NC ⊕	084343 TP1-538K024M	-	-
			4131 2 NC ⊕ + 2 NO	084150 TP1-4131K024M	084254 TP1-4131K110M	084255 TP1-4131K230M
		2 Electrical	528 1 NC ⊕ + 1 NO	084344 TP2-528K024M	-	-
			538 2 NC ⊕	084346 TP2-538K024M	-	-
			4131 2 NC ⊕ + 2 NO	084253 TP2-4131K024M	-	-

1) With cable entry M, DC 24 V / AC 110 V

Cable entry M20 x 1.5

Dimension drawing

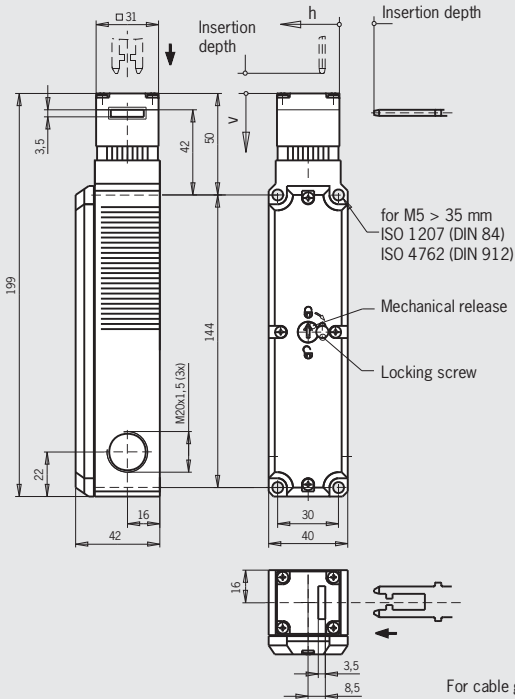

Wiring diagrams actuator inserted and locked

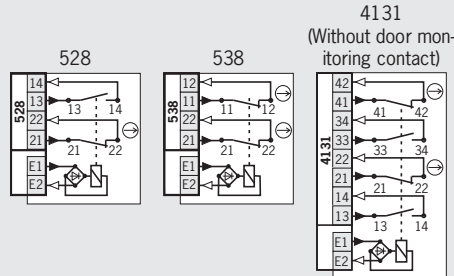

For switching functions, see technical data on page 135



Plug connector SR6 6-pin + PE

Dimension drawing

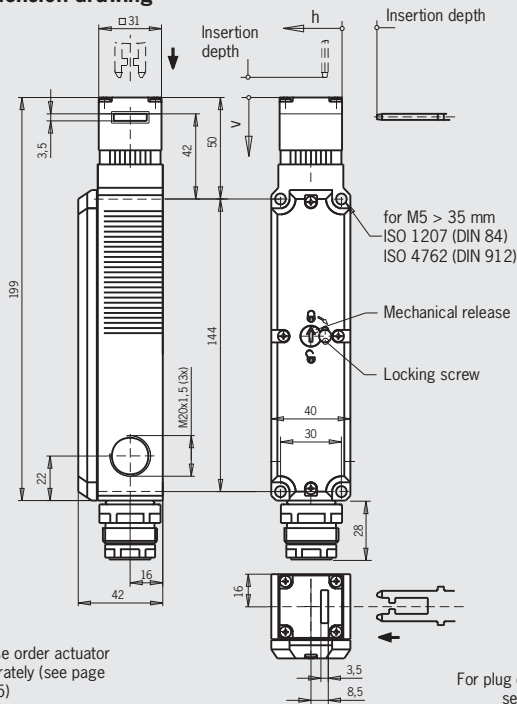

Plug connector SR11 11-pin + PE

Dimension drawing

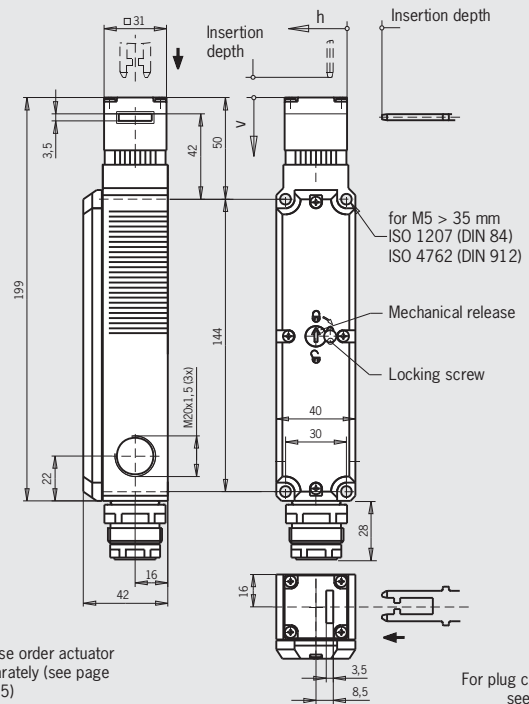

Wiring diagrams actuator inserted and locked

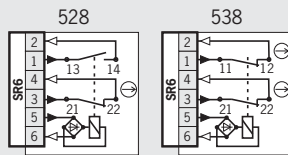

For switching functions, see technical data on page 135

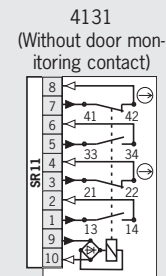

For switching functions, see technical data on page 135

Ordering table

Series	Connection	Guard locking	Switching element	Solenoid operating voltage	
				AC/DC 24 V	
TP	SR6 Plug connector	1 Mechanical	528 1 NC ⊖ + 1 NO	088210 TP1-528K024SR6	
			538 2 NC ⊖	088212 TP1-538K024SR6	
		2 Electrical	528 1 NC ⊖ + 1 NO	088214 TP2-528K024SR6	
			538 2 NC ⊖	088215 TP2-538K024SR6	
	SR11 Plug connector	1 Mechanical	4131 2 NC ⊖ + 2 NO	088217 TP1-4131K024SR11	
		2 Electrical	4131 2 NC ⊖ + 2 NO	088218 TP2-4131K024SR11	

Safety switch TP with guard locking and guard locking monitoring



- ▶ Mechanical release on the front
- ▶ With door monitoring contact
- ▶ Increased horizontal overtravel



Approach direction



Horizontally and vertically adjustable in 90° steps
Increased overtravel for horizontal approach direction.

Mechanical release

Is used for releasing the guard locking with the aid of a tool. To protect against tampering, the mechanical release is sealed with sealing lacquer.

Solenoid operating voltage

- ▶ AC/DC 24 V +10%, -15%
- ▶ AC 110 V +10%, -15%
- ▶ AC 230 V +10%, -15%

Guard locking types

TP3 Closed-circuit current principle, guard locking by spring force. Release by applying voltage to the guard locking solenoid.

TP4 Open-circuit current principle, guard locking by applying voltage to the guard locking solenoid. Release by spring force.

Switching elements

- ▶ **537** Slow-action switching contact
1 NC ⊖ + 1 NC (door monitoring contact)
- ▶ **2131** Slow-action switching contact
2 NC ⊖ + 1 NO + 1 NC (door monitoring contact)
- ▶ **4121** Slow-action switching contact
2 NC ⊖ + 1 NC / 1 NO (door monitoring contact)
- ▶ **4131** Slow-action switching contact
2 NC ⊖ + 1 NO + 1 NO (door monitoring contact)
- ▶ **4141** Slow-action switching contact
2 NC ⊖ + 2 NC ⊖ (door monitoring contact)

Cable entry M20 x 1.5

Dimension drawing

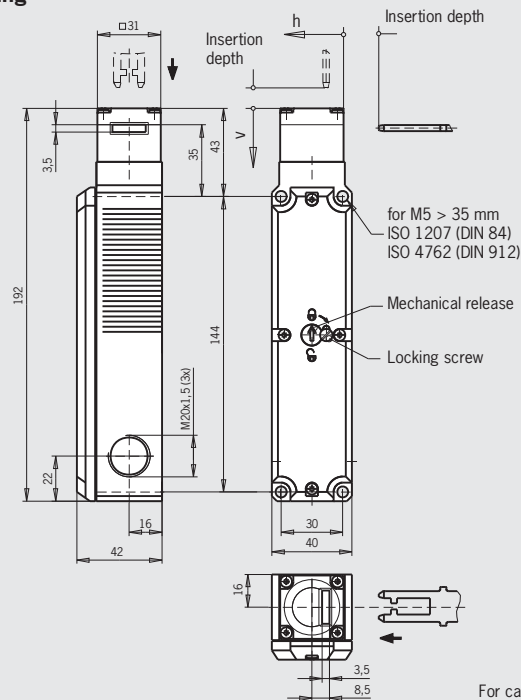

Wiring diagrams actuator inserted and locked

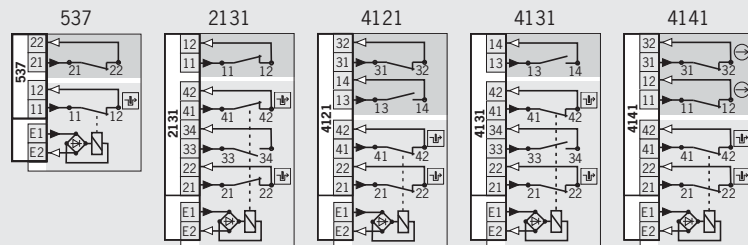

For switching functions, see technical data on page 136

- Solenoid monitoring
- Door monitoring

Ordering table

Series	Connection	Guard locking	Switching element	Version	Solenoid operating voltage		
					AC/DC 24 V	AC 110 V	AC 230 V
TP	M Cable entry 3 x M20 x 1.5	3 Mechanical	537 1 NC ⊖ + 1 NC	C1761 Cable gland in rear of housing	084336 TP3-537A024M	084337 TP3-537A110M	084338 TP3-537A230M
			2131 2 NC ⊖ + 1 NO + 1 NC		084142 TP3-2131A024M	084143 TP3-2131A110M	084144 TP3-2131A230M
			2131 2 NC ⊖ + 1 NO + 1 NC		084290 ²⁾ TP3-2131A024MC1761	-	-
			4121 2 NC ⊖ + 1 NC / 1 NO		084135 TP3-4121A024M	084137 TP3-4121A110M	084138 TP3-4121A230M
			4131 2 NC ⊖ + 1 NO + 1 NO		084129 TP3-4131A024M	084130 TP3-4131A110M	084131 TP3-4131A230M
			4141 2 NC ⊖ + 2 NC ⊖		084270 TP3-4141A024M	088264 TP3-4141A110M	-

1) With cable entry M, DC 24 V / AC 110 V 2) No approvals



Cable entry M20 x 1.5

Dimension drawing
(Version C1761, see ordering table page 48)

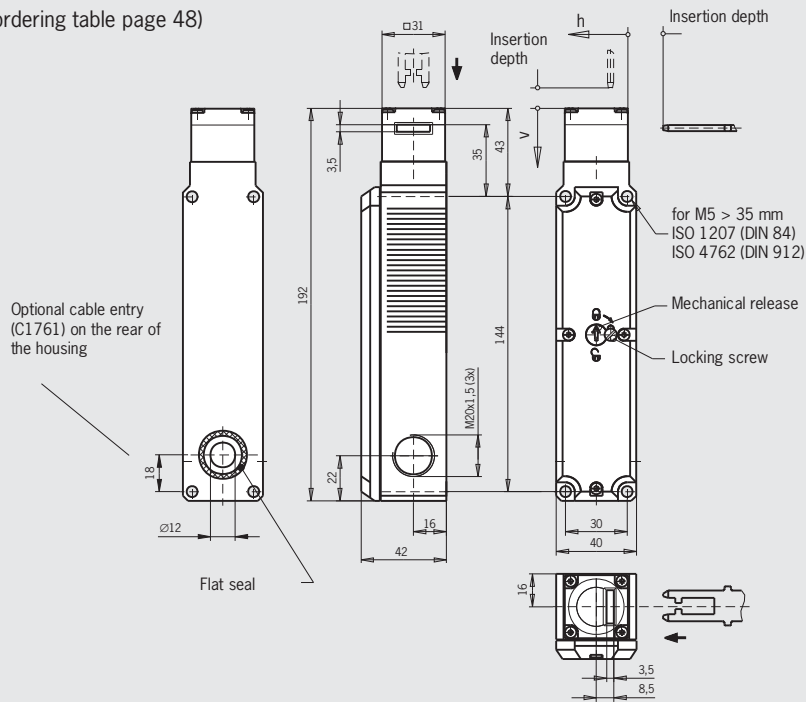

Please order actuator separately (see page 92-95)

For cable glands, see page 108

Wiring diagrams actuator inserted and locked

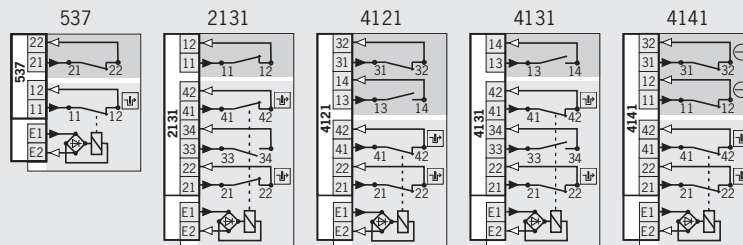

- Solenoid monitoring
- Door monitoring

For switching functions, see technical data on page 136

Ordering table

Series	Connection	Guard locking	Switching element	Version	Solenoid operating voltage		
					AC/DC 24 V	AC 110 V	AC 230 V
TP	M Cable entry 3 x M20 x 1.5	4 Electrical	537 1 NC \overline{E} + 1 NC		084339 TP4-537A024M	084340 TP4-537A110M	084341 TP4-537A230M
			2131 2 NC \overline{E} + 1 NO + 1 NC		084145 TP4-2131A024M	084147 TP4-2131A110M	084148 TP4-2131A230M
			4121 2 NC \overline{E} + 1 NC / 1 NO		084139 TP4-4121A024M	084140 TP4-4121A110M	084141 TP4-4121A230M
			4131 2 NC \overline{E} + 1 NO + 1 NO		084132 TP4-4131A024M	084133 TP4-4131A110M	084134 TP4-4131A230M
			4141 2 NC \overline{E} + 2 NC \ominus		084275 TP4-4141A024M	-	-

1) With cable entry M, DC 24 V / AC 110 V

Safety switch TP with guard locking and guard locking monitoring



- ▶ Mechanical release on the front
- ▶ With door monitoring contact
- ▶ Increased horizontal overtravel



Approach direction



Horizontally and vertically adjustable in 90° steps
Increased overtravel for horizontal approach direction.

Mechanical release

Is used for releasing the guard locking with the aid of a tool. To protect against tampering, the mechanical release is sealed with sealing lacquer.

Solenoid operating voltage

- ▶ AC/DC 24 V +10%, -15%

LED function display

A function display (2 LEDs, red and green) is available for the following voltage ranges:

- ▶ AC/DC 24 V +10%, -15%

Guard locking types

TP3 Closed-circuit current principle, guard locking by spring force. Release by applying voltage to the guard locking solenoid.

TP4 Open-circuit current principle, guard locking by applying voltage to the guard locking solenoid. Release by spring force.

Switching elements

- ▶ **537** Slow-action switching contact
1 NC ⊖ + 1 NC (door monitoring contact)
- ▶ **2131** Slow-action switching contact
2 NC ⊖ + 1 NO + 1 NC (door monitoring contact)
- ▶ **4121** Slow-action switching contact
2 NC ⊖ + 1 NC / 1 NO (door monitoring contact)
- ▶ **4131** Slow-action switching contact
2 NC ⊖ + 1 NO + 1 NO (door monitoring contact)
- ▶ **4141** Slow-action switching contact
2 NC ⊖ + 2 NC ⊖ (door monitoring contact)

Cable entry M20 x 1.5

Dimension drawing

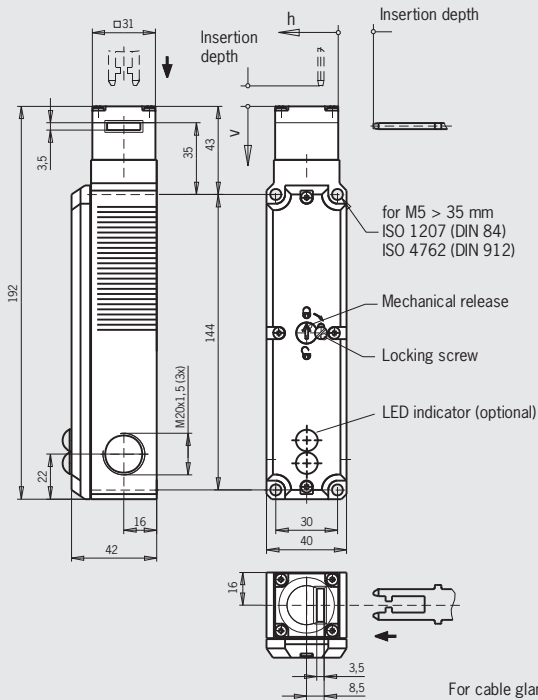

Please order actuator separately (see page 92-95)

For cable glands, see page 108

Wiring diagrams actuator inserted and locked

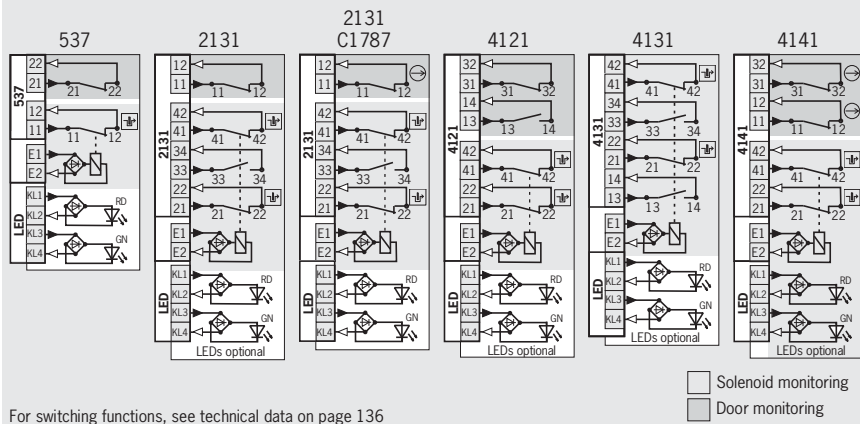

For switching functions, see technical data on page 136

Ordering table

Series	Connection	Guard locking	Switching element	Version	Solenoid operating voltage
					AC/DC 24 V
TP	M Cable entry 3 x M20 x 1.5	3 Mechanical	537 1 NC ⊖ + 1 NC	024L LED indicator AC/DC 24 V	093460 TP3-537A024L024M
			2131 2 NC ⊖ + 1 NO + 1 NC	024L LED indicator AC/DC 24 V	093634 TP3-2131A024L024M
			2131 2 NC ⊖ + 1 NO + 1 NC ⊖	C1787 3 positively driven contacts	084289 TP3-2131A024M1787
			4121 2 NC ⊖ + 1 NC / 1 NO	024L LED indicator AC/DC 24 V	093636 TP3-4121A024L024M
			4131 2 NC ⊖ + 1 NO + 1 NO	024L LED indicator AC/DC 24 V	098403 TP3-4131A024L024M
			4141 2 NC ⊖ + 2 NC ⊖	024L LED indicator AC/DC 24 V	137709 TP3-4141A024L024M



Cable entry M20 x 1.5

Dimension drawing

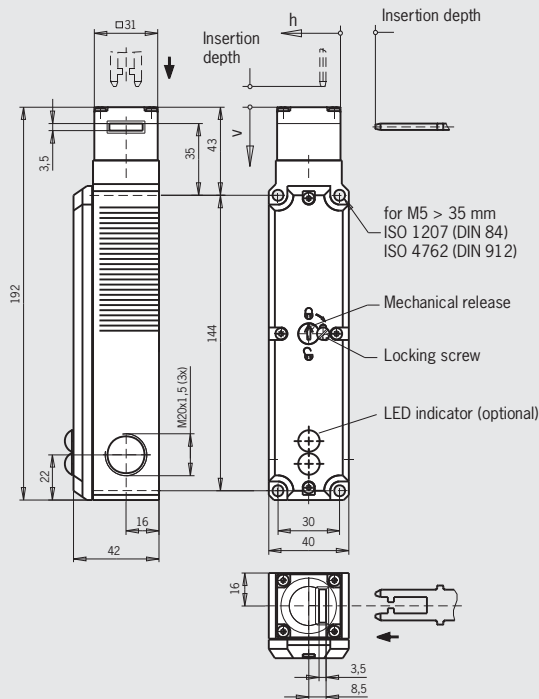

Please order actuator separately (see page 92-95)

For cable glands, see page 108

Wiring diagrams actuator inserted and locked

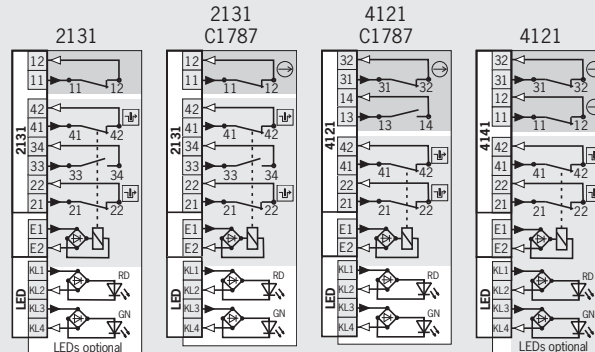

- Solenoid monitoring
- Door monitoring

For switching functions, see technical data on page 136

Ordering table

Series	Connection	Guard locking	Switching element	Version	Solenoid operating voltage
					AC/DC 24 V
TP	M Cable entry 3 x M20 x 1.5	4 Electrical	2131 2 NC $\overline{\text{I}}$ + 1 NO + 1 NC	024L LED indicator AC/DC 24 V	093635 TP4-2131A024L024M
			2131 2 NC $\overline{\text{I}}$ + 1 NO + 1 NC \ominus	C1787 3 positively driven contacts	084159 TP4-2131A024MC1787
			4121 2 NC $\overline{\text{I}}$ + 1 NC / 1 NO	024L LED indicator AC/DC 24 V	093637 TP4-4121A024L024M
			4121 2 NC $\overline{\text{I}}$ + 1 NC \ominus + 1 NO	C1787 3 positively driven contacts	084160 TP4-4121A024MC1787

Safety switch TP with guard locking and guard locking monitoring

- ▶ Mechanical release on the front
- ▶ With door monitoring contact
- ▶ Increased horizontal overtravel



Approach direction



Horizontally and vertically adjustable in 90° steps
Increased overtravel for horizontal approach direction.

Mechanical release

Is used for releasing the guard locking with the aid of a tool. To protect against tampering, the mechanical release is sealed with sealing lacquer.

Solenoid operating voltage

- ▶ AC/DC 24 V +10%, -15%
- ▶ AC 110 V +10%, -15%
- ▶ AC 230 V +10%, -15%

Guard locking types

- TP3** Closed-circuit current principle, guard locking by spring force. Release by applying voltage to the guard locking solenoid.
- TP4** Open-circuit current principle, guard locking by applying voltage to the guard locking solenoid. Release by spring force.

Switching elements

- ▶ **537** Slow-action switching contact
1 NC ⊖ + 1 NC (door monitoring contact)
- ▶ **2131** Slow-action switching contact
2 NC ⊖ + 1 NO + 1 NC (door monitoring contact)
- ▶ **4121** Slow-action switching contact
2 NC ⊖ + 1 NC / 1 NO (door monitoring contact)
- ▶ **4131** Slow-action switching contact
2 NC ⊖ + 1 NO + 1 NO (door monitoring contact)
- ▶ **4141** Slow-action switching contact
2 NC ⊖ + 2 NC ⊖ (door monitoring contact)

Ordering table

Series	Connection	Guard locking	Switching element	Version	Solenoid operating voltage		
					AC/DC 24 V	AC 110 V	AC 230 V
TP	SR6 Plug connector	3 Mechanical	537 1 NC ⊖ + 1 NC		087434 TP3-537A024SR6	087437 TP3-537A110SR6	087440 TP3-537A230SR6
		4 Electrical	537 1 NC ⊖ + 1 NC		087443 TP4-537A024SR6	087447 TP4-537A110SR6	087450 TP4-537A230SR6
	SM8 Plug connector M12	3 Mechanical	4141 2 NC ⊖ + 2 NC ⊖	C1992 Direct connection to safe bus module	087377 TP3-4141A024SM8C1992	-	-
		4 Electrical	4141 2 NC ⊖ + 2 NC ⊖	C1992 Direct connection to safe bus module	087378 TP4-4141A024SM8C1992	-	-

1) Only with solenoid operating voltage AC/DC 24 V



Plug connector SR6 6-pin + PE

Dimension drawing

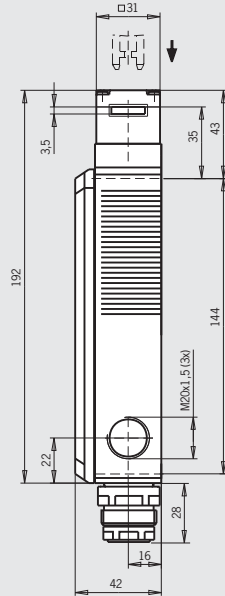

Please order actuator separately (see page 92-95)

For plug connectors, see page 104

Plug connector SM8 Plug M12, 8-pin

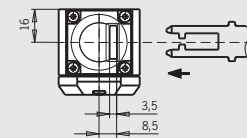
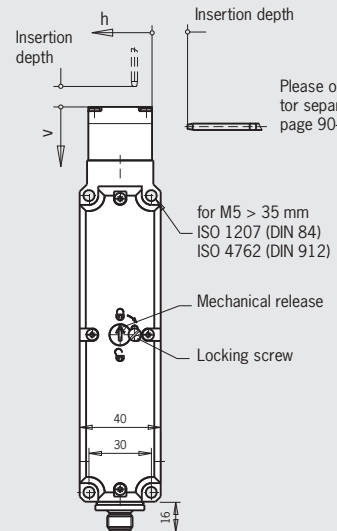

For plug connectors, see page 103

Wiring diagrams actuator inserted and locked

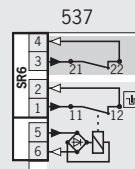

- Solenoid monitoring
- Door monitoring

For switching functions, see technical data on page 136

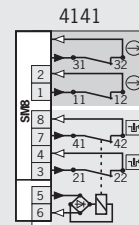

- Solenoid monitoring
- Door monitoring

For switching functions, see technical data on page 136



Plug connector SR11
11-pin + PE

Dimension drawing

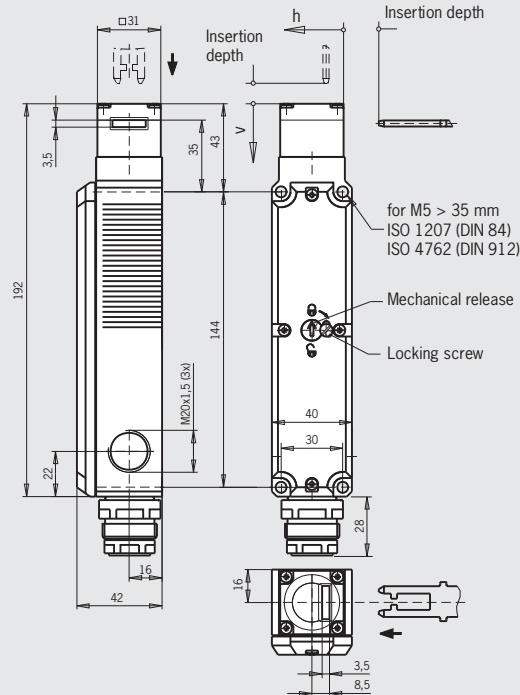

Please order actuator separately (see page 92-95)

For plug connectors, see page 104

Wiring diagrams actuator inserted and locked

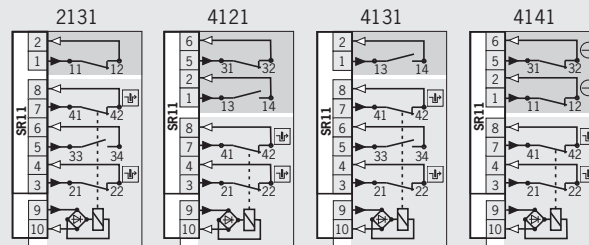

□ Solenoid monitoring
■ Door monitoring

For switching functions, see technical data on page 136

Ordering table

Series	Connection	Guard locking	Switching element	Solenoid operating voltage	
				AC/DC 24 V	
TP	SR11 Plug connector	3 Mechanical	2131 2 NC + 1 NO + 1 NC	088205 TP3-2131A024SR11	
			4121 2 NC + 1 NC / 1 NO	088206 TP3-4121A024SR11	
			4131 2 NC + 1 NO + 1 NO	088204 TP3-4131A024SR11	
			4141 2 NC + 2 NC	088922 TP3-4141A024SR11	
		4 Electrical	2131 2 NC + 1 NO + 1 NC	088208 TP4-2131A024SR11	
			4121 2 NC + 1 NC / 1 NO	088209 TP4-4121A024SR11	
			4131 2 NC + 1 NO + 1 NO	088207 TP4-4131A024SR11	
			4141 2 NC + 2 NC	088923 TP4-4141A024SR11	

1) Only with solenoid operating voltage AC/DC 24 V

Safety switch TP with guard locking and guard locking monitoring



- ▶ Mechanical release on the front
- ▶ With door monitoring contact
- ▶ Increased overtravel for horizontal and vertical approach direction.



Approach direction



Horizontally and vertically adjustable in 90° steps
Increased overtravel for horizontal and vertical approach direction.

Mechanical release

Is used for releasing the guard locking with the aid of a tool. To protect against tampering, the mechanical release is sealed with sealing lacquer.

Solenoid operating voltage

- ▶ AC/DC 24 V +10%, -15%
- ▶ AC 110 V +10%, -15%
- ▶ AC 230 V +10%, -15%

Guard locking types

- TP3** Closed-circuit current principle, guard locking by spring force. Release by applying voltage to the guard locking solenoid.
- TP4** Open-circuit current principle, guard locking by applying voltage to the guard locking solenoid. Release by spring force.

Switching elements

- ▶ **537** Slow-action switching contact
1 NC ⊕ + 1 NC (door monitoring contact)
- ▶ **2131** Slow-action switching contact
2 NC ⊕ + 1 NO + 1 NC (door monitoring contact)
- ▶ **4121** Slow-action switching contact
2 NC ⊕ + 1 NC / 1 NO (door monitoring contact)
- ▶ **4131** Slow-action switching contact
2 NC ⊕ + 1 NO + 1 NO (door monitoring contact)
- ▶ **4141** Slow-action switching contact
2 NC ⊕ + 2 NC ⊕ (door monitoring contact)

Cable entry M20 x 1.5

Dimension drawing

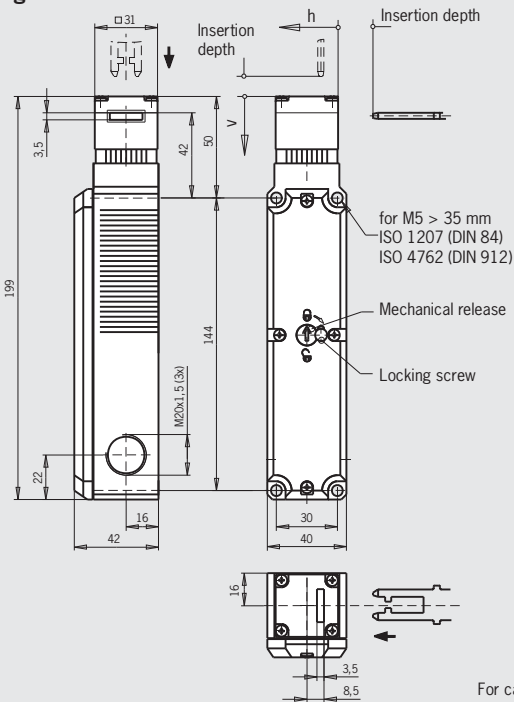

Please order actuator separately (see page 92-95)

For cable glands, see page 108

Wiring diagrams actuator inserted and locked

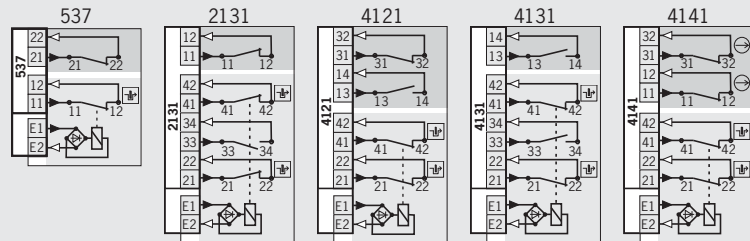

For switching functions, see technical data on page 136

- Solenoid monitoring
- Door monitoring

Ordering table

Series	Connection	Guard locking	Switching element	Version	Solenoid operating voltage		
					AC/DC 24 V	AC 110 V	AC 230 V
TP	M Cable entry 3 x M20 x 1.5	3 Mechanical	537 1 NC ⊕ + 1 NC		084347 TP3-537K024M	-	-
			2131 2 NC ⊕ + 1 NO + 1 NC		084264 TP3-2131K024M	-	084265 TP3-2131K230M
			4121 2 NC ⊕ + 1 NC / 1 NO		084260 TP3-4121K024M	084261 TP3-4121K110M	084262 TP3-4121K230M
			4131 2 NC ⊕ + 1 NO + 1 NO		084256 TP3-4131K024M	084257 TP3-4131K110M	084258 TP3-4131K230M
			4141 2 NC ⊕ + 2 NC ⊕		100684 TP3-4141K024M	-	-
			537 1 NC ⊕ + 1 NC		084348 TP4-537K024M	084349 TP4-537K110M	-
		4 Electrical	2131 2 NC ⊕ + 1 NO + 1 NC		084266 TP4-2131K024M	-	-
			4121 2 NC ⊕ + 1 NC / 1 NO		084263 TP4-4121K024M	084380 TP4-4121K110M	-
			4131 2 NC ⊕ + 1 NO + 1 NO		084259 TP4-4131K024M	-	-
			4141 2 NC ⊕ + 2 NC ⊕		096296 TP4-4141K024M	-	-
			537 1 NC ⊕ + 1 NC		084348 TP4-537K024M	084349 TP4-537K110M	-
			2131 2 NC ⊕ + 1 NO + 1 NC		084266 TP4-2131K024M	-	-

1) With cable entry M, DC 24 V / AC 110 V



Plug connector SR6 6-pin + PE

Plug connector SR11 11-pin + PE

Dimension drawing

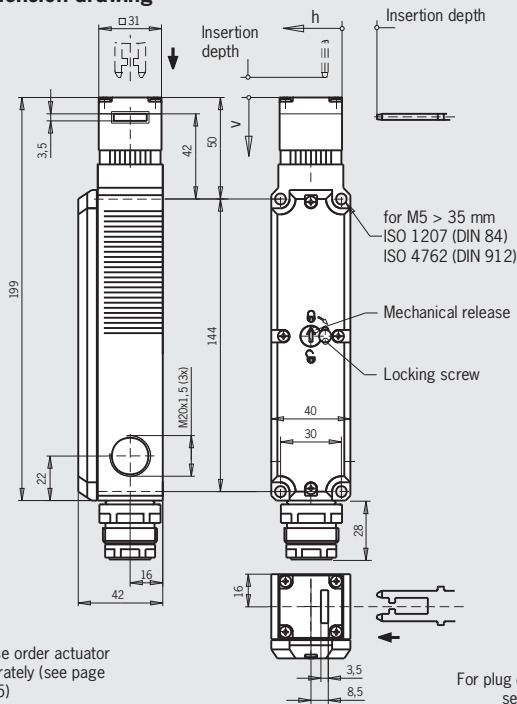

Please order actuator separately (see page 92-95)

For plug connectors, see page 104

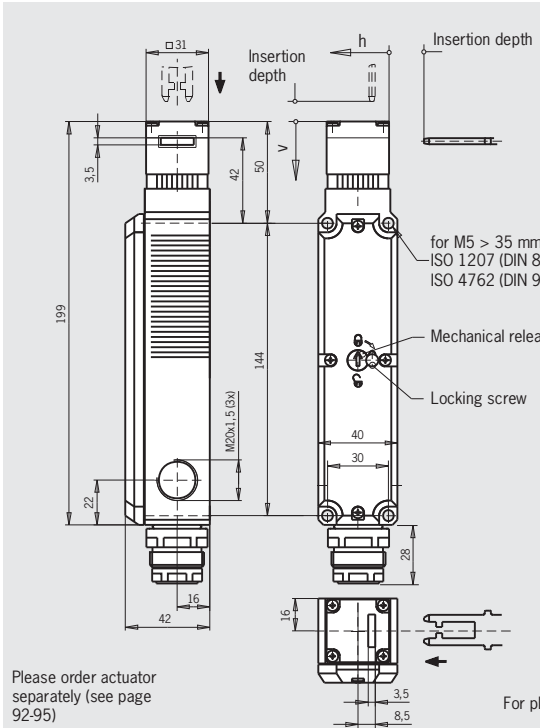

Please order actuator separately (see page 92-95)

For plug connectors, see page 104

Wiring diagrams actuator inserted and locked

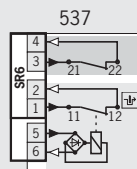

Solenoid monitoring
 Door monitoring

For switching functions, see technical data on page 136

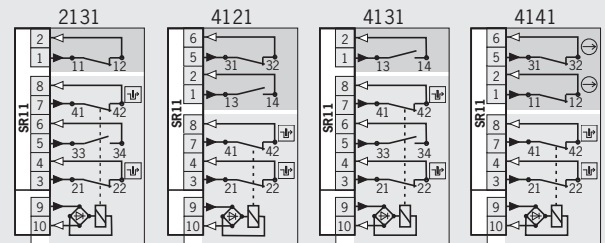

Solenoid monitoring
 Door monitoring

For switching functions, see technical data on page 136

Ordering table

Series	Connection	Guard locking	Switching element	Solenoid operating voltage	
				AC/DC 24 V	
TP	SR6 Plug connector	3 Mechanical	537 1 NC $\overline{\text{tr}}$ + 1 NC	088213 TP3-537K024SR6	
		4 Electrical	537 1 NC $\overline{\text{tr}}$ + 1 NC	088216 TP4-537K024SR6	
	SR11 Plug connector	3 Mechanical	2131 2 NC $\overline{\text{tr}}$ + 1 NO + 1 NC	088220 TP3-2131K024SR11	
			4121 2 NC $\overline{\text{tr}}$ + 1 NC / 1 NO	088221 TP3-4121K024SR11	
			4131 2 NC $\overline{\text{tr}}$ + 1 NO + 1 NO	088219 TP3-4131K024SR11	
		4 Electrical	2131 2 NC $\overline{\text{tr}}$ + 1 NO + 1 NC	088223 TP4-2131K024SR11	
			4121 2 NC $\overline{\text{tr}}$ + 1 NC / 1 NO	088224 TP4-4121K024SR11	
			4131 2 NC $\overline{\text{tr}}$ + 1 NO + 1 NO	088222 TP4-4131K024SR11	
			4141 2 NC $\overline{\text{tr}}$ + 2 NC \ominus	088230 TP4-4141K024SR11	

Safety switch TP with guard locking and guard locking monitoring



- ▶ Auxiliary shutdown feature on the front
- ▶ With door unlock request contact
- ▶ Increased horizontal overtravel



Approach direction



Horizontally and vertically adjustable in 90° steps
Increased overtravel for horizontal approach direction.

Auxiliary shutdown feature

When actuated, positively driven contacts 21-22 are opened. The guard remains locked. The auxiliary shutdown feature must be sealed to prevent tampering (for example with sealing lacquer).

Door unlock request contact

When the actuator is in the locked state positively driven contact 21-22 is opened by pulling the guard (6 mm actuator stroke) as a result of which a signal is forwarded to the controlling PLC. Depending on the control concept, the guard can be unlocked automatically when machine components that were still running have stopped.

Solenoid operating voltage

- ▶ AC/DC 24 V +10%, -15%
- ▶ AC 230 V +10%, -15%

LED function display (optional)

A function display (2 LEDs, red and green) is available for the following voltage ranges:

- ▶ AC/DC 24 V +10%, -15%

Guard locking types

- TP5** Closed-circuit current principle, guard locking by spring force. Release by applying voltage to the guard locking solenoid.
- TP6** Open-circuit current principle, guard locking by applying voltage to the guard locking solenoid. Release by spring force.

Switching elements

- ▶ **4120** Slow-action switching contact
1 NC ⊖ (door unlock request contact) + 1 NC ⊕ + 1 NO (solenoid monitoring contact)

Cable entry M20 x 1.5

Dimension drawing

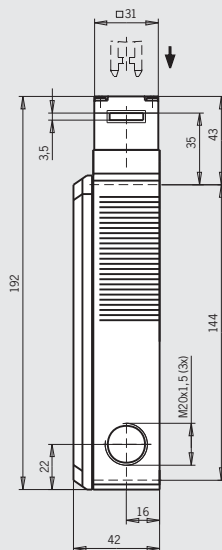

Please order actuator separately (see page 92-95)

For cable glands, see page 108

Plug connector SR11

11-pin + PE

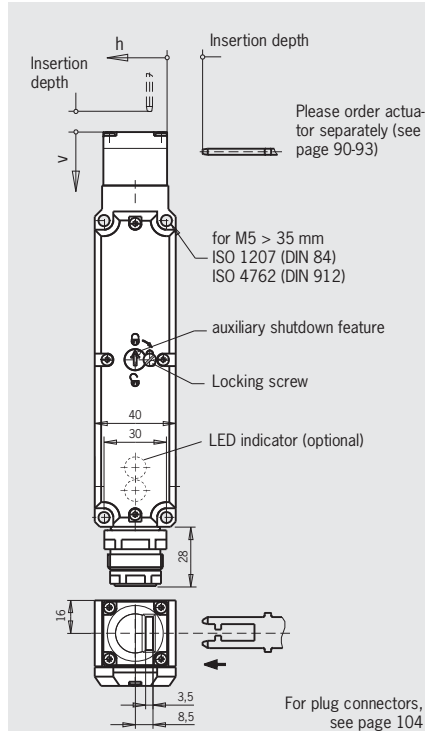

Wiring diagrams actuator inserted and locked

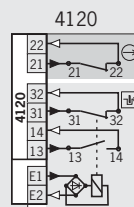

- Solenoid monitoring
- Door unlock request contact

For switching functions, see technical data on page 136

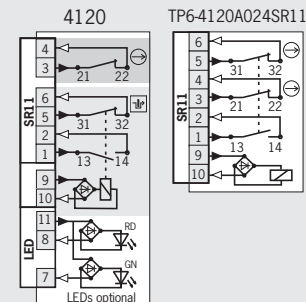

- Solenoid monitoring
- Door unlock request contact

For switching functions, see technical data on page 136

Ordering table

Series	Connection	Guard locking	Switching element	Version	Solenoid operating voltage	
					AC/DC 24 V	AC 230 V
TP	M Cable entry 3 x M20 x 1.5	5 Mechanical	4120 1 NC ⊖ + 1 NC ⊕ + 1 NO		084279 TP5-4120A024M	088241 TP5-4120A230M
		6 Electrical	4120 1 NC ⊖ + 1 NC ⊕ + 1 NO		084280 TP6-4120A024M	-
	SR11 Plug connector	5 Mechanical	4120 1 NC ⊖ + 1 NC ⊕ + 1 NO		094895 TP5-4120A024SR11	-
		5 Mechanical	4120 1 NC ⊖ + 1 NC ⊕ + 1 NO	024L LED indicator AC/DC 24 V	094902 TP5-4120A024L024SR11	-
		6 Electrical	4120 1 NC ⊖ + 1 NC ⊕ + 1 NO		096204 TP6-4120A024SR11	-

Safety switch TP with guard locking and guard locking monitoring

- ▶ Escape release from the rear
- ▶ With door monitoring contact
- ▶ Increased horizontal overtravel



Approach direction



Horizontally and vertically adjustable in 90° steps
Increased overtravel for horizontal approach direction.

Escape release

This is used for manual release of guard locking from within the danger zone without tools. With identification of On/Off position.

Solenoid operating voltage

- ▶ AC/DC 24 V +10%, -15%

Guard locking types

TP3 Closed-circuit current principle, guard locking by spring force. Release by applying voltage to the guard locking solenoid.

Switching elements

- ▶ **2131** Slow-action switching contact
2 NC \ominus + 1 NO + 1 NC (door monitoring contact)
- ▶ **4121** Slow-action switching contact
2 NC \ominus + 1 NC / 1 NO (door monitoring contact)
- ▶ **4131** Slow-action switching contact
2 NC \ominus + 1 NO + 1 NO (door monitoring contact)
- ▶ **4141** Slow-action switching contact
2 NC \ominus + 2 NC \ominus (door monitoring contact)

Cable entry M20 x 1.5

Dimension drawing

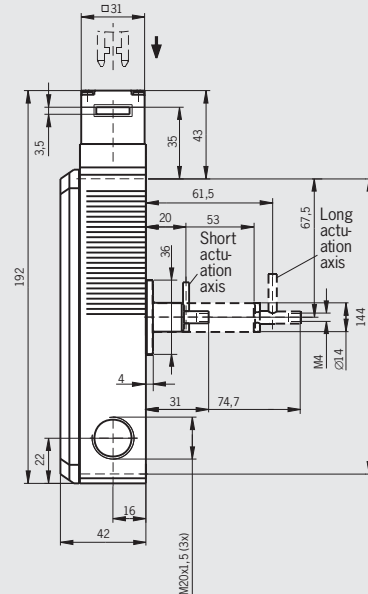

Please order actuator separately (see page 92-95)

For cable glands, see page 108

Plug connector SR11

11-pin + PE

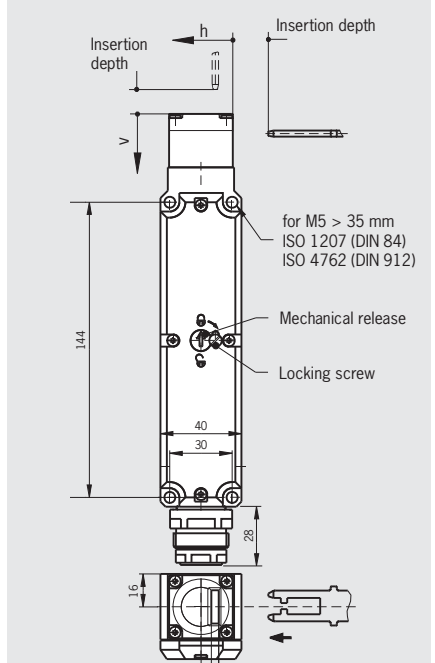

Please order actuator separately (see page 92-95)

For plug connectors, see page 104

Wiring diagrams actuator inserted and locked

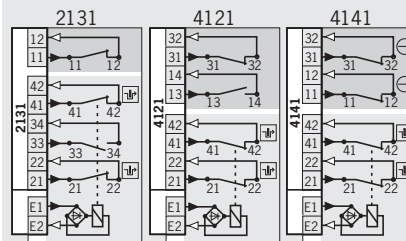

- Solenoid monitoring
- Door monitoring

For switching functions, see technical data on page 136

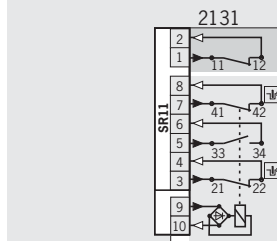

- Solenoid monitoring
- Door monitoring

For switching functions, see technical data on page 136

Ordering table

Series	Connection	Guard locking	Switching element	Version	Solenoid operating voltage	
					AC/DC 24 V	
TP	M Cable entry 3 x M20 x 1.5	3 Mechanical	2131 2 NC \ominus + 1 NO + 1 NC	C1743 Short actuator shaft	084285 TP3-2131A024MC1743	
				C1993 Long actuator shaft	087400 TP3-2131A024MC1993	
			4121 2 NC \ominus + 1 NC / 1 NO	C1743 Short actuator shaft	087427 TP3-4121A024MC1743	
				C1993 Long actuator shaft	106155 TP3-4131A024MC1993	
	SR11 Plug con- nector	3 Mechanical	2131 2 NC \ominus + 2 NC \ominus	C1743 Short actuator shaft	086165 TP3-4141A024MC1743	
				C1993 Long actuator shaft	097897 TP3-2131A024SR11C1993	

Safety switch TP with guard locking and guard locking monitoring

- ▶ Mechanical release on the front
- ▶ Pushbutton and cover for indicators
- ▶ With door monitoring contact
- ▶ Increased horizontal overtravel



Approach direction



Horizontally and vertically adjustable in 90° steps
Increased overtravel for horizontal approach direction.

Mechanical release

Is used for releasing the guard locking with the aid of a tool. To protect against tampering, the mechanical release is sealed with sealing lacquer.

Solenoid operating voltage

- ▶ AC/DC 24 V +10%, -15%

Cover for indicators

A cover for indicators (1 LED, green) is available for the following voltage ranges:

- ▶ DC 24 V +10%, -15%

Guard locking types

TP3 Closed-circuit current principle, guard locking by spring force. Release by applying voltage to the guard locking solenoid.

Switching elements

- ▶ **4121** Slow-action switching contact
2 NC ⊖ + 1 NC / 1 NO (door monitoring contact)
- ▶ **4141** Slow-action switching contact
2 NC ⊖ + 2 NC ⊖ (door monitoring contact)

Plug connector BHA12 12-pin

Dimension drawing

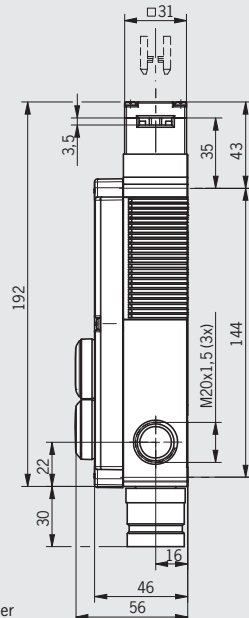

Please order actuator separately (see page 92-95)

For plug connectors, see page 107

Plug connector M23 (RC18) 18-pin + PE

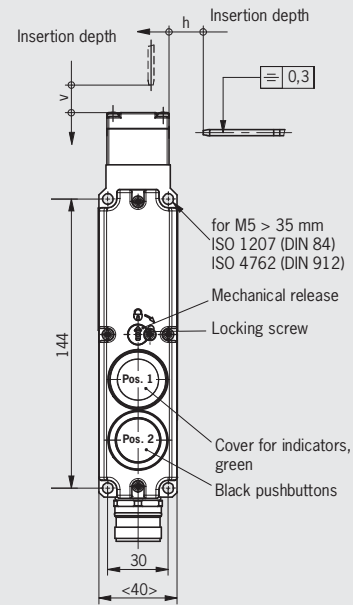

Please order actuator separately (see page 92-95)

For plug connectors, see page 105/106

Wiring diagrams actuator inserted and locked

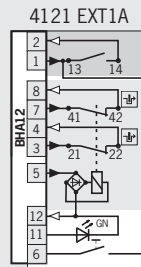

- Solenoid monitoring
- Door monitoring

For switching functions, see technical data on page 136

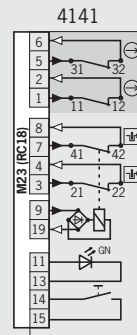

- Solenoid monitoring
- Door monitoring

For switching functions, see technical data on page 132

Ordering table

Series	Connection	Guard locking	Switching element	Version	Solenoid operating voltage
					AC/DC 24 V
TP	BHA12 Plug connector	3 Mechanical	4121 2 NC ⊖ + 1 NC / 1 NO	Pos. 1 Cover for indicators, green Pos. 2 Black pushbuttons	105388 TP3-4121A024BHA12EXT1A
	M23 (RC18) Plug connector	3 Mechanical	4141 2 NC ⊖ + 2 NC ⊖	Pos. 1 Cover for indicators, green Pos. 2 Black pushbuttons	103339 TP3-4141A024RC18EXT1

Safety switch TP with guard locking and guard locking monitoring



- ▶ Escape release from the rear
- ▶ 2 illuminated pushbuttons
- ▶ With door monitoring contact
- ▶ Increased horizontal overtravel



Approach direction



Horizontally and vertically adjustable in 90° steps
Increased overtravel for horizontal approach direction.

Escape release

This is used for manual release of guard locking from within the danger zone without tools. With identification of On/Off position.

Solenoid operating voltage

- ▶ AC/DC 24 V +10%, -15%

Pushbutton LED

A cover for indicators (1 LED, green) is available for the following voltage ranges:

- ▶ DC 24 V +10%, -15%

Guard locking types

TP3 Closed-circuit current principle, guard locking by spring force. Release by applying voltage to the guard locking solenoid.

Switching elements

- ▶ **2131** Slow-action switching contact
2 NC \ominus + 1 NO + 1 NC (door monitoring contact)

Plug connector M23 (RC18)
18-pin + PE

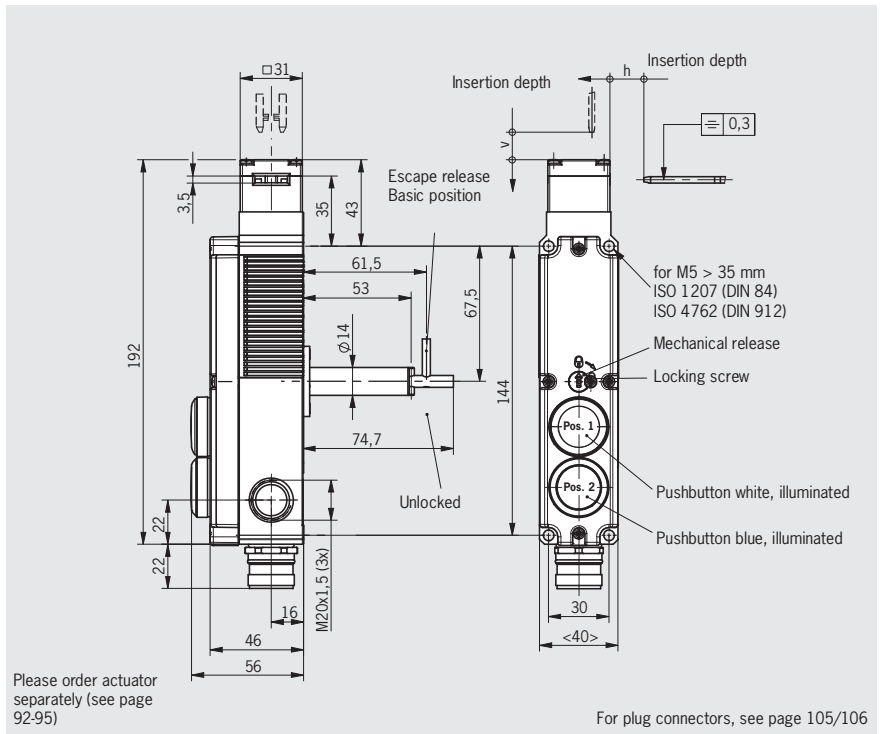

Wiring diagrams actuator inserted and locked

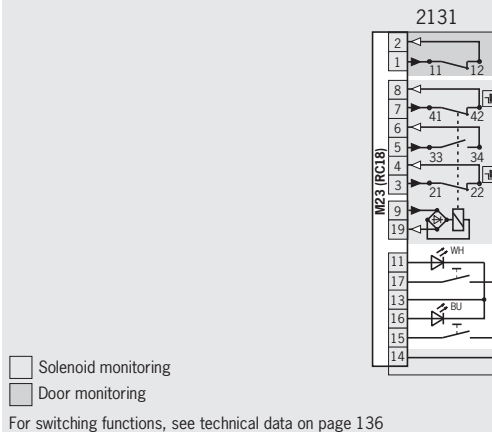

Ordering table

Series	Connection	Guard locking	Switching element	Version	Solenoid operating voltage
					AC/DC 24 V
TP	M23 (RC18) Plug connector	3 Mechanical	2131 2 NC \ominus + 1 NO + 1 NC	C1993 Long actuator shaft Pos. 1 White pushbutton Pos. 2 Blue pushbutton	105546 TP3-2131A024RC18C1993EXT2

Selection table for safety switches STP with guard locking and guard locking monitoring

Version										
Standard			One actuating head made of metal							
BI			BiState, with additional safety function							
TW			TWIN, 2 actuating heads made of metal							
Release feature										
HE			Mechanical release on the front							
FE			Escape release on the rear							
Door monitoring										
STP3/4			With door monitoring contact							
STP1/2			Without door monitoring contact							
Connection										
M			Thread M20x1.5 for cable gland							
SR11			Plug connector 11-pin + PE							
M23 (RC18)			Plug connector 18-pin + PE							
Version		Release feature			Door monitoring		Connection			Page
Standard	BI	TW	HE	FE	STP3/4	STP1/2	M	SR11	M23 (RC18)	
●			●		●		●	●	●	62 - 65
●			●			●	●			66
●			●	●	●		●	●		67
●			●	●	●	●			●	68 - 70
	●		●		●			●		71
		●	●		●		●	●		72 - 73

Safety switch STP with guard locking and guard locking monitoring



- ▶ Actuating head made of metal
- ▶ Mechanical release on the front
- ▶ With door monitoring contact



Approach direction

Horizontally and vertically adjustable in 90° steps

Mechanical release

Is used for releasing the guard locking with the aid of a tool. To protect against tampering, the mechanical release is sealed with sealing lacquer.

Solenoid operating voltage

- ▶ AC/DC 24 V +10%, -15%
- ▶ AC 110 V +10%, -15%
- ▶ AC 230 V +10%, -15%

LED function display (optional)

A function display (2 LEDs, red and green) is available for the following voltage ranges:

- ▶ AC/DC 24 V +10%, -15%

Guard locking types

STP3 Closed-circuit current principle, guard locking by spring force. Release by applying voltage to the guard locking solenoid.

STP4 Open-circuit current principle, guard locking by applying voltage to the guard locking solenoid. Release by spring force.

Switching elements

- ▶ **537** Slow-action switching contact
1 NC ⊖ + 1 NC (door monitoring contact)
- ▶ **2131** Slow-action switching contact
2 NC ⊖ + 1 NO + 1 NC (door monitoring contact)
- ▶ **4121** Slow-action switching contact
2 NC ⊖ + 1 NC / 1 NO (door monitoring contact)
- ▶ **4131** Slow-action switching contact
2 NC ⊖ + 1 NO + 1 NO (door monitoring contact)
- ▶ **4141** Slow-action switching contact
2 NC ⊖ + 2 NC ⊖ (door monitoring contact)

Cable entry M20 x 1.5

Dimension drawing

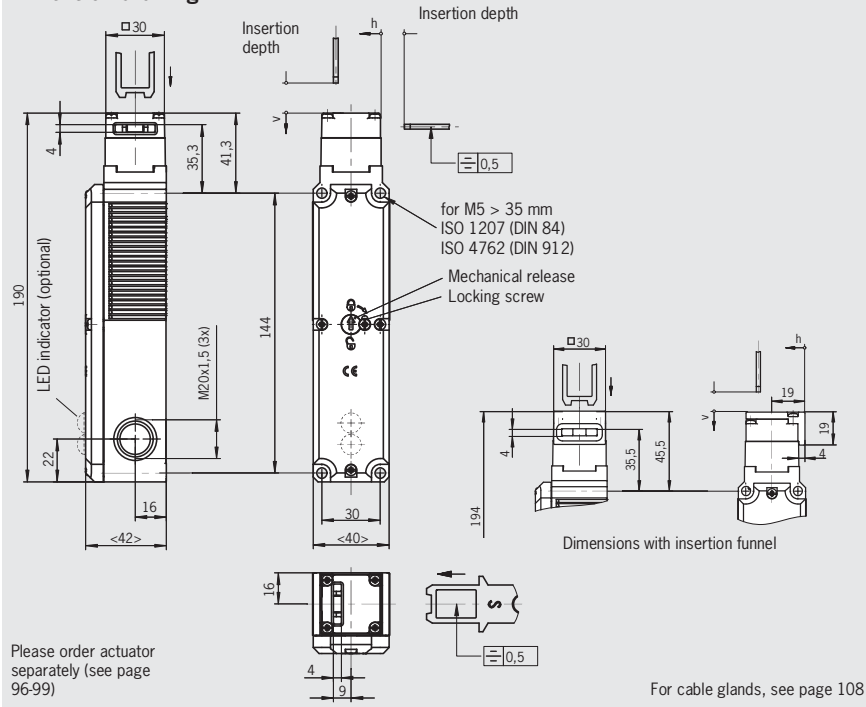

Wiring diagrams actuator inserted and locked

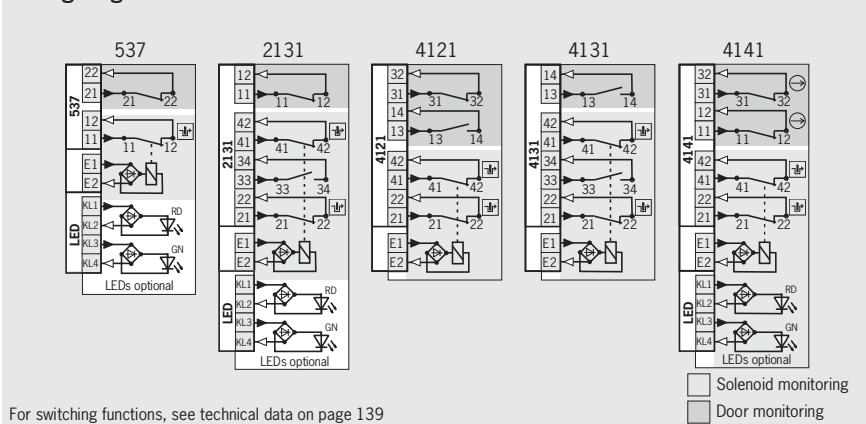

Ordering table

Series	Connection	Guard locking	Switching element	Version	Solenoid operating voltage		
					AC/DC 24 V	AC 110 V	AC 230 V
STP	M Cable entry 3 x M20 x 1.5	3 Mechanical	537 1 NC ⊖ + 1 NC	024L LED indicator AC/DC 24 V D With insertion funnel	097210 STP3D-537A024L024M	-	-
				2131 2 NC ⊖ + 1 NO + 1 NC	091493 STP3A-2131A024M	099326 STP3A-2131A110M	105972 STP3A-2131A230M
			4121 2 NC ⊖ + 1 NC / 1 NO	024L LED indicator AC/DC 24 V	091748 STP3A-2131A024L024M	-	-
				096890 STP3A-4121A024M	-	094792 STP3A-4121A230M	
			4131 2 NC ⊖ + 1 NO + 1 NO	091776 STP3A-4131A024M	-	-	
				099272 STP3A-4141A024M	-	-	
			4141 2 NC ⊖ + 2 NC ⊖	024L LED indicator AC/DC 24 V D With insertion funnel	112093 STP3A-4141A024L024M	-	-
				097891 STP3D-4141A024M	-	-	
				024L LED indicator AC/DC 24 V D With insertion funnel	099412 STP3D-4141A024L024M	-	-

1) With cable entry M, DC 24 V / AC 110 V

Cable entry M20 x 1.5

Dimension drawing

Please order actuator separately (see page 96-99)

For cable glands, see page 108

Wiring diagrams actuator inserted and locked

For switching functions, see technical data on page 139

Solenoid monitoring
 Door monitoring

Ordering table

Series	Connection	Guard locking	Switching element	Version	Solenoid operating voltage		
					AC/DC 24 V	AC 110 V	AC 230 V
STP	M Cable entry 3 x M20 x 1.5	4 Electrical	537 1 NC + 1 NC		092259 STP4A-537A024M	-	-
			2131 2 NC + 1 NO + 1 NC		091494 STP4A-2131A024M	097754 STP4A-2131A110M	-
				024L LED indicator AC/DC 24 V	091749 STP4A-2131A024L024M	-	-
			4121 2 NC + 1 NC / 1 NO		093159 STP4A-4121A024M	094793 STP4A-4121A110M	094794 STP4A-4121A230M
				024L LED indicator AC/DC 24 V	100026 STP4A-4121A024L024M	-	-
			4131 2 NC + 1 NO + 1 NO		093158 STP4A-4131A024M	-	104153 STP4A-4131A230M
4141 2 NC + 2 NC		099314 STP4A-4141A024M	-	-			

1) With cable entry M, DC 24 V / AC 110 V

Please turn over

For technical data, see page 121



Plug connector SR11 11-pin + PE

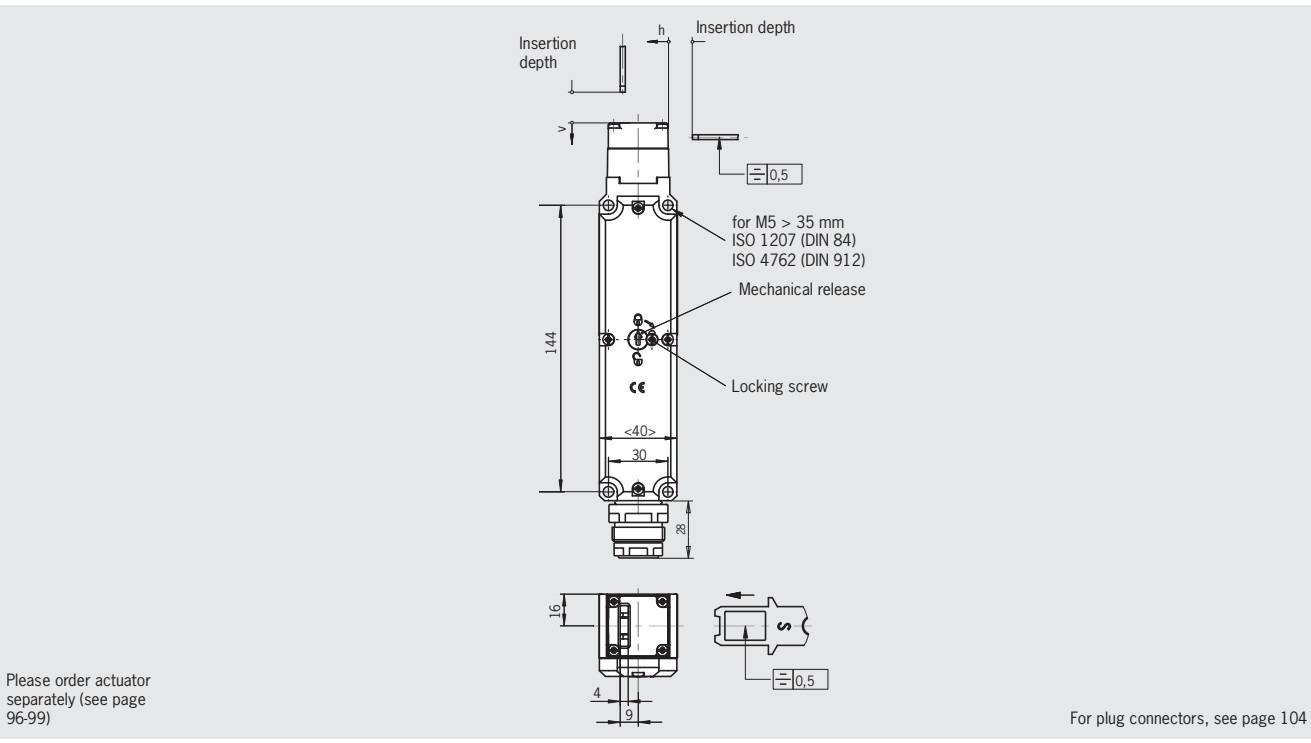

Please order actuator separately (see page 96.99)

For plug connectors, see page 104

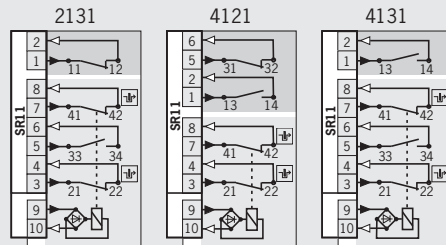

For switching functions, see technical data on page 139

Solenoid monitoring
 Door monitoring

Ordering table

Series	Connection	Guard locking	Switching element	Version	Solenoid operating voltage	
					AC/DC 24 V	
STP	SR11 Plug connector	3 Mechanical	2131 2 NC + 1 NO + 1 NC		099069 STP3A-2131A024SR11	
			4121 2 NC + 1 NC / 1 NO		096318 STP3A-4121A024SR11	
			4131 2 NC + 1 NO + 1 NO		103994 STP3A-4131A024SR11	
		4 Electrical	2131 2 NC + 1 NO + 1 NC		097565 STP4A-2131A024SR11	
			4121 2 NC + 1 NC / 1 NO		099301 STP4A-4121A024SR11	
			4131 2 NC + 1 NO + 1 NO		111259 STP4A-4131A024SR11	



Plug connector M23 (RC18)
18-pin + PE

Dimension drawing

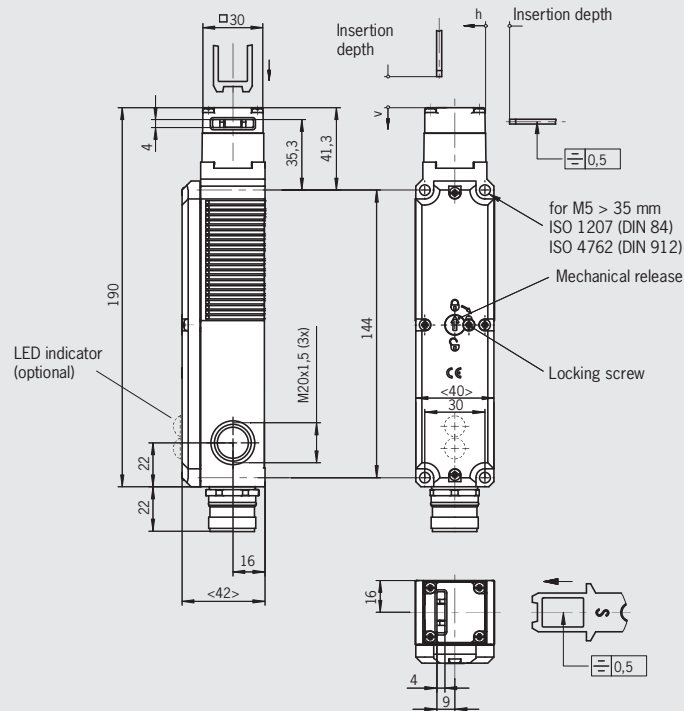

For plug connectors, see page 101/102

Wiring diagrams actuator inserted and locked

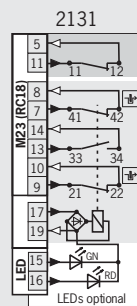

- Solenoid monitoring
- Door monitoring

For switching functions, see technical data on page 139

Ordering table

Series	Connection	Guard locking	Switching element	Version	Solenoid operating voltage
					AC/DC 24 V
STP	M23 (RC18) Plug connector	3 Mechanical	2131 2 NC + 1 NO + 1 NC	024L LED indicator AC/DC 24 V	099644 STP3A-2131A024L024RC18

Safety switch STP with guard locking and guard locking monitoring



- ▶ Actuating head made of metal
- ▶ Mechanical release on the front
- ▶ Without door monitoring contact



Approach direction



Horizontally and vertically adjustable in 90° steps

Mechanical release

Is used for releasing the guard locking with the aid of a tool. To protect against tampering, the mechanical release is sealed with sealing lacquer.

Solenoid operating voltage

- ▶ AC/DC 24 V +10%, -15%
- ▶ AC 230 V +10%, -15%

LED function display (optional)

A function display (2 LEDs, red and green) is available for the following voltage ranges:

- ▶ AC/DC 24 V +10%, -15%

Guard locking types

- STP1** Closed-circuit current principle, guard locking by spring force. Release by applying voltage to the guard locking solenoid.
- STP2** Open-circuit current principle, guard locking by applying voltage to the guard locking solenoid. Release by spring force.

Switching elements

- ▶ **528** Slow-action switching contact
1 NC ⊕ + 1 NO
- ▶ **538** Slow-action switching contact
2 NC ⊕
- ▶ **4131** Slow-action switching contact
2 NC ⊕ + 2 NO

Cable entry M20 x 1.5

Dimension drawing

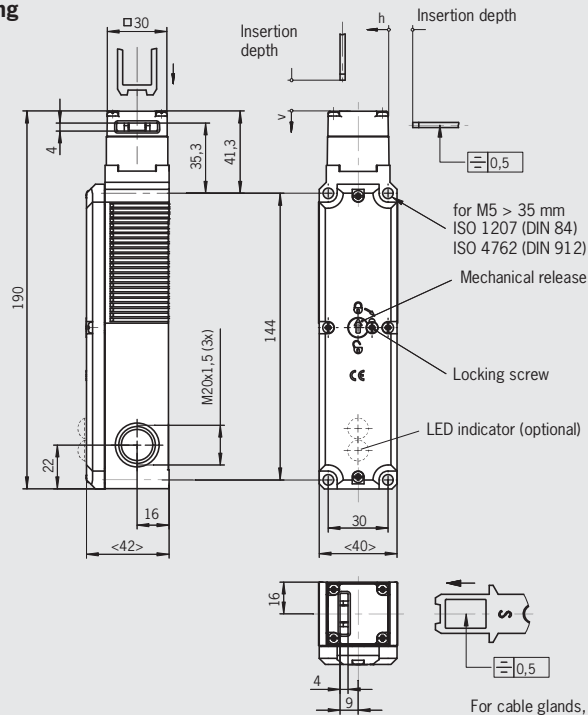

Wiring diagrams actuator inserted and locked

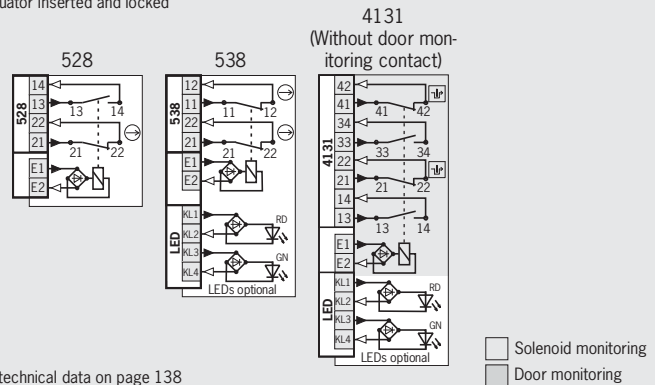

Ordering table

Series	Connection	Guard locking	Switching element	Version	Solenoid operating voltage
					AC/DC 24 V
STP	M Cable entry 3 x M20 x 1.5	1 Mechanical	528 1 NC ⊕ + 1 NO	024L LED indicator AC/DC 24 V With pre-assembled insertion funnel	092266 STP1A-528A024M
					092258 STP1A-538A024M
					092489 STP1D-538A024L024M
		2 Electrical	528 1 NC ⊕ + 1 NO	024L LED indicator AC/DC 24 V	091491 STP1A-4131A024M
					091746 STP1A-4131A024L024M
			538 2 NC ⊕	024L LED indicator AC/DC 24 V	099855 STP2A-528A024M
					092260 STP2A-538A024M
			4131 2 NC ⊕ + 2 NO	024L LED indicator AC/DC 24 V	092490 STP2A-538A024L024M
					091492 STP2A-4131A024M
091747 STP2A-4131A024L024M					

Safety switch STP with guard locking and guard locking monitoring



- ▶ Escape release on the rear
- ▶ With door monitoring contact



Approach direction



Horizontally and vertically adjustable in 90° steps

Escape release

This is used for manual release of guard locking from within the danger zone without tools. With identification of On/Off position.

Solenoid operating voltage

- ▶ AC/DC 24 V +10%, -15%

Guard locking types

STP3 Closed-circuit current principle, guard locking by spring force. Release by applying voltage to the guard locking solenoid.

STP4 Open-circuit current principle, guard locking by applying voltage to the guard locking solenoid. Release by spring force.

Switching elements

- ▶ **2131** Slow-action switching contact
2 NC ⊕ + 1 NO + 1 NC (door monitoring contact)
- ▶ **4121** Slow-action switching contact
2 NC ⊕ + 1 NC / 1 NO (door monitoring contact)
- ▶ **4141** Slow-action switching contact
2 NC ⊕ + 2 NC ⊖ (door monitoring contact)

Cable entry M20 x 1.5

Dimension drawing

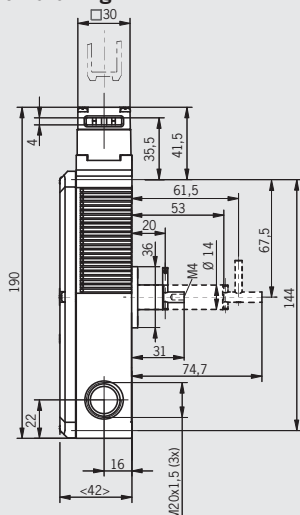

Please order actuator separately (see page 96-99)

For cable glands, see page 108

Plug connector SR11 11-pin + PE

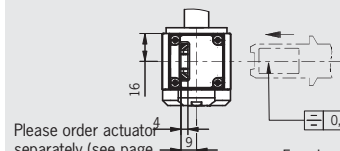
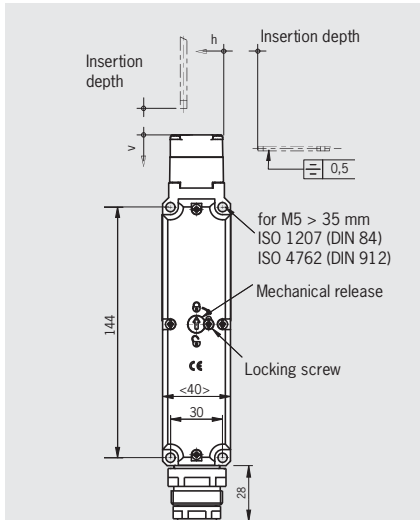

Please order actuator separately (see page 96-99)

For plug connectors, see page 104

Wiring diagrams actuator inserted and locked

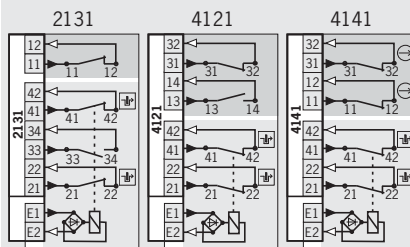

- Solenoid monitoring
- Door monitoring

For switching functions, see technical data on page 139

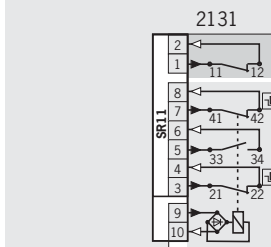

- Solenoid monitoring
- Door monitoring

For switching functions, see technical data on page 139

Ordering table

Series	Connection	Guard locking	Switching element	Version	Solenoid operating voltage	
					AC	DC 24 V
STP	M Cable entry 3 x M20 x 1.5	3 Mechanical	2131 2 NC ⊕ + 1 NO + 1 NC	C1993 Long actuator shaft	102267 STP3A-2131A024MC1993	
			4121 2 NC ⊕ + 1 NC / 1 NO	C1743 Short actuator shaft	111064 STP3A-2131A024MC1743	
		4 Electrical	4121 2 NC ⊕ + 1 NC / 1 NO	C1993 Long actuator shaft	096885 STP3A-4121A024MC1993	
			4141 2 NC ⊕ + 2 NC ⊖	C1993 Long actuator shaft	100322 STP4A-4121A024MC1993	115749 STP4A-4141A024MC1993
	SR11 Plug connector	3 Mechanical	2131 2 NC ⊕ + 1 NO + 1 NC	C1993 Long actuator shaft	103223 STP3A-2131A024SR11C1993	

Safety switch STP with guard locking and guard locking monitoring



- ▶ Actuating head made of metal
- ▶ Mechanical release on the front
- ▶ Pushbutton and cover for indicators
- ▶ Without door monitoring contact



Approach direction



Horizontally and vertically adjustable in 90° steps

Mechanical release

Is used for releasing the guard locking with the aid of a tool. To protect against tampering, the mechanical release is sealed with sealing lacquer.

Solenoid operating voltage

- ▶ AC/DC 24 V +10%, -15%

Cover for indicators

A cover for indicators (1 LED, green) is available for the following voltage ranges:

- ▶ DC 24 V +10%, -15%

Guard locking types

STP1 Closed-circuit current principle, guard locking by spring force. Release by applying voltage to the guard locking solenoid.

Switching elements

- ▶ **528** Slow-action switching contact
1 NC \ominus + 1 NO

Plug connector M23 (RC18)

18-pin + PE

Dimension drawing

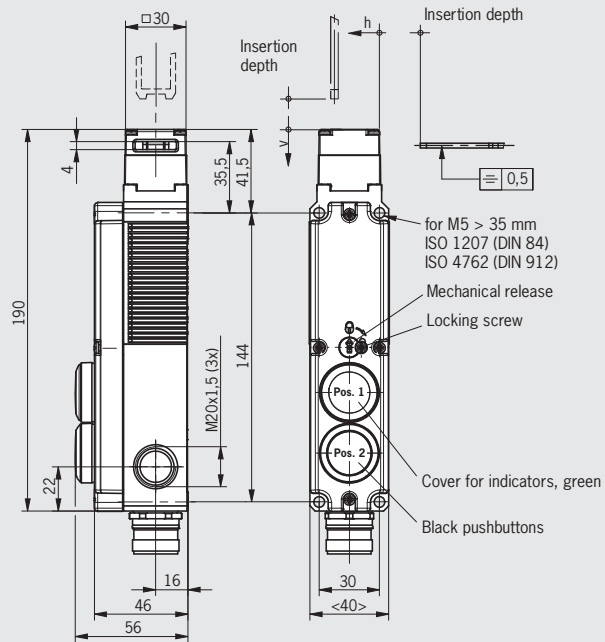

Please order actuator separately (see page 96-99)

For plug connectors, see page 101/102

Wiring diagrams actuator inserted and locked

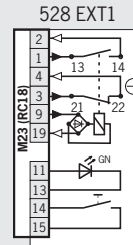

For switching functions, see technical data on page 138

Ordering table

Series	Connection	Guard locking	Switching element	Version	Solenoid operating voltage
					AC/DC 24 V
STP	M23 (RC18) Plug connector	1 Mechanical	528 1 NC \ominus + 1 NO	Pos. 1: Cover for indicators, green Pos. 2: Black pushbuttons	106767 STP1A-528A024RC18EXT1

Safety switch STP with guard locking and guard locking monitoring



- ▶ Actuating head made of metal
- ▶ Mechanical release on the front
- ▶ Pushbutton and cover for indicators
- ▶ With door monitoring contact



Approach direction



Horizontally and vertically adjustable in 90° steps

Mechanical release

Is used for releasing the guard locking with the aid of a tool. To protect against tampering, the mechanical release is sealed with sealing lacquer.

Solenoid operating voltage

- ▶ AC/DC 24 V +10%, -15%

Cover for indicators

A cover for indicators (1 LED, green) is available for the following voltage ranges:

- ▶ DC 24 V +10%, -15%

Guard locking types

STP3 Closed-circuit current principle, guard locking by spring force. Release by applying voltage to the guard locking solenoid.

Switching elements

- ▶ **4141** Slow-action switching contact
2 NC ⊕ + 2 NC ⊖ (door monitoring contact)

Plug connector M23 (RC18)
18-pin + PE

Dimension drawing

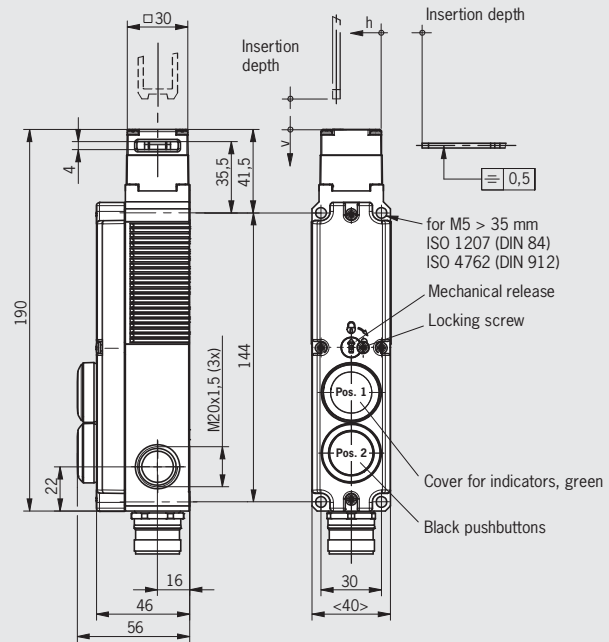

Please order actuator separately (see page 96-99)

For plug connectors, see page 101/102

Wiring diagrams actuator inserted and locked

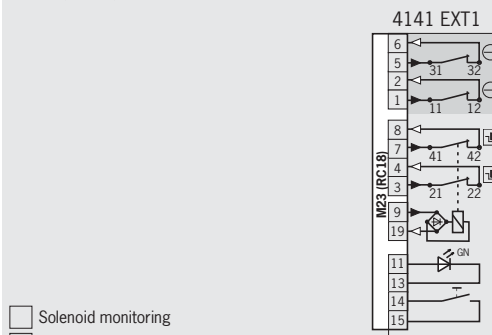

☐ Solenoid monitoring

☐ Door monitoring

For switching functions, see technical data on page 139

Ordering table

Series	Connection	Guard locking	Switching element	Version	Solenoid operating voltage
					AC/DC 24 V
STP	M23 (RC18) Plug connector	3 Mechanical	4141 2 NC ⊕ + 2 NC ⊖	Pos. 1: Cover for indicators, green Pos. 2: Black pushbuttons	104995 STP3A-4141A024RC18EXT1

Safety switch STP with guard locking and guard locking monitoring



- ▶ Actuating head made of metal
- ▶ Escape release on the rear
- ▶ 2 illuminated pushbuttons
- ▶ With door monitoring contact



Approach direction



Horizontally and vertically adjustable in 90° steps

Escape release

This is used for manual release of guard locking from within the danger zone without tools. With identification of On/Off position.

Solenoid operating voltage

- ▶ AC/DC 24 V +10%, -15%

Pushbutton LED

A cover for indicators (1 LED, green) is available for the following voltage ranges:

- ▶ DC 24 V +10%, -15%

Guard locking types

STP3 Closed-circuit current principle, guard locking by spring force. Release by applying voltage to the guard locking solenoid.

Switching elements

- ▶ **4141** Slow-action switching contact
2 NC \ominus + 2 NC \ominus (door monitoring contact)

Plug connector M23 (RC18)

18-pin + PE

Dimension drawing

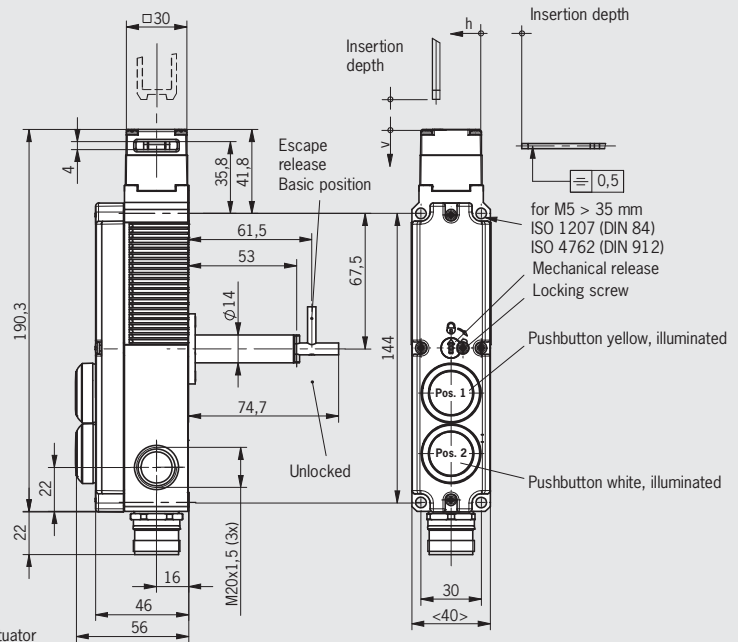

Please order actuator separately (see page 96-99)

For plug connectors, see page 101/102

Wiring diagrams

Actuator inserted and locked

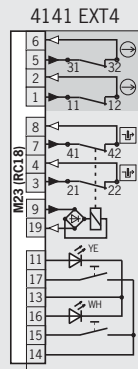

- Solenoid monitoring
- Door monitoring

For switching functions, see technical data on page 139

Ordering table

Series	Connection	Guard locking	Switching element	Version	Solenoid operating voltage
					AC/DC 24 V
STP	M23 (RC18) Plug connector	3 Mechanical	4141 2 NC \oplus + 2 NC \ominus	C1993 Long actuator shaft Pos. 1: yellow pushbutton Pos. 2: White pushbutton	109399 STP3A-4141A024RC18C1993EXT4

Safety switch STP-BI with guard locking and guard locking monitoring



- ▶ Actuating head made of metal
- ▶ Mechanical release on the front
- ▶ Additional function BI-State
- ▶ With door monitoring contact



Approach direction



Horizontally and vertically adjustable in 90° steps

Mechanical release

Is used for releasing the guard locking with the aid of a tool. To protect against tampering, the mechanical release is sealed with sealing lacquer.

Additional function BI-State

In addition, the STP-BI has a function to prevent

- ▶ persons from unintentionally locking themselves inside if the safety door is open in case of a power failure or if the machine is switched off
- ▶ the deactivation of the activated guard locking in case of a power failure.

Solenoid operating voltage

- ▶ AC/DC 24 V +10%, -15%

Guard locking types

STP3 Closed-circuit current principle, guard locking by spring force. Release by applying voltage to the guard locking solenoid.

Switching elements

- ▶ **2131** Slow-action switching contact
2 NC ⊖ + 1 NO + 1 NC (door monitoring contact)

Plug connector SR11

11-pin + PE

Dimension drawing

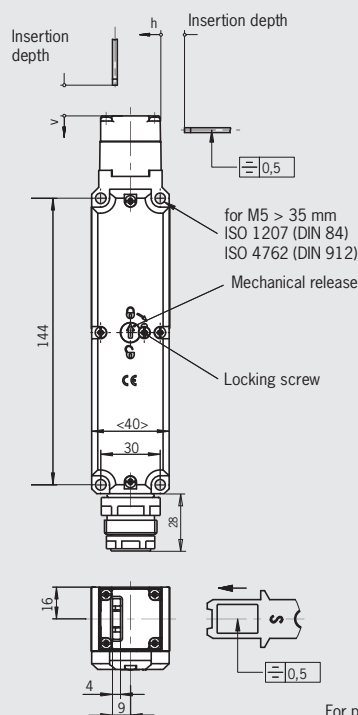

Please order actuator separately (see page 96-99)

For plug connectors, see page 104

Wiring diagrams actuator inserted and locked

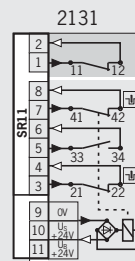

For switching functions, see technical data on page 139

- ☐ Solenoid monitoring
- ☐ Door monitoring

Ordering table

Series	Connection	Guard locking	Switching element	Version	Solenoid operating voltage
					AC/DC 24 V
STP-BI	SR11 Plug connector	3 Mechanical	2131 2 NC ⊖ + 1 NO + 1 NC		100105 STP-BI-3A-2131A024SR11

Safety switch STP-TW with guard locking and guard locking monitoring



- ▶ Actuating heads made of metal
- ▶ Simultaneous monitoring of two safety doors
- ▶ Mechanical release on the front
- ▶ Mechanical key release optional
- ▶ With door monitoring contact



Approach direction



Horizontally and vertically adjustable in 90° steps

Mechanical release

Is used for releasing the guard locking with the aid of a tool. To protect against tampering, the mechanical release is sealed with sealing lacquer.

Mechanical key release

Additional lock on the switch head. Function as for mechanical release. The mechanical key release setting is indicated in the window. Two keys are included.

Solenoid operating voltage

- ▶ AC/DC 24 V +10%, -15%

LED function display (optional)

A function display (2 LEDs, red and green) is available for the following voltage ranges:

- ▶ AC/DC 24 V +10%, -15%

Guard locking types

STP3 Closed-circuit current principle, guard locking by spring force. Release by applying voltage to the guard locking solenoid.

STP4 Open-circuit current principle, guard locking by applying voltage to the guard locking solenoid. Release by spring force.

Switching elements

- ▶ **2131** Slow-action switching contact
2 NC ⊕ + 1 NO + 1 NC (door monitoring contact)
- ▶ **4131** Slow-action switching contact
2 NC ⊕ + 1 NO + 1 NO (door monitoring contact)
- ▶ **4141** Slow-action switching contact
2 NC ⊕ + 2 NC ⊖ (door monitoring contact)

Ordering table

Series	Connection	Guard locking	Switching element	Version	Solenoid operating voltage
					AC/DC 24 V
STP-TW	Cable entry 3 x M20 x 1.5	3 Mechanical	2131 2 NC ⊕ + 1 NO + 1 NC	With mechanical key release (identical locking)	099973 STP-TW-3A-2131AC024M
					098827 STP-TW-3A-2131AC024M-S1
			4131 2 NC ⊕ + 1 NO + 1 NO		106153 STP-TW-3A-4131AC024M
					100746 STP-TW-3A-4141AC024M
			4141 2 NC ⊕ + 2 NC ⊖	024L LED indicator AC/DC 24 V	103048 STP-TW-3A-4141AC024L024M

Cable entry M20 x 1.5

Dimension drawing

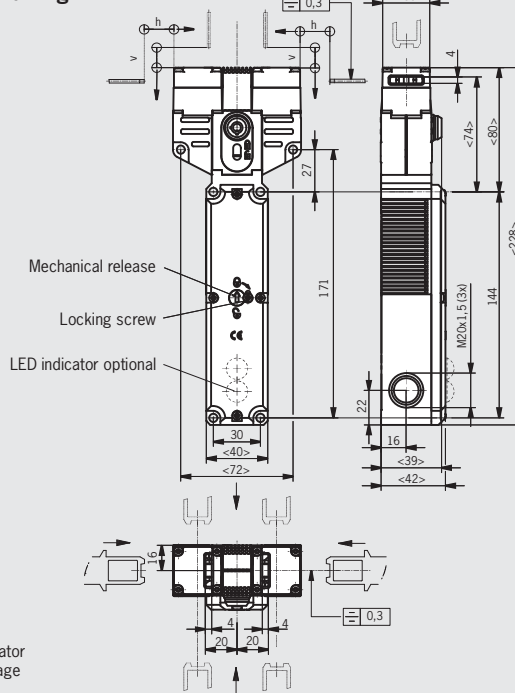

Please order actuator separately (see page 96-99)

For cable glands, see page 108

Wiring diagrams actuator inserted and locked

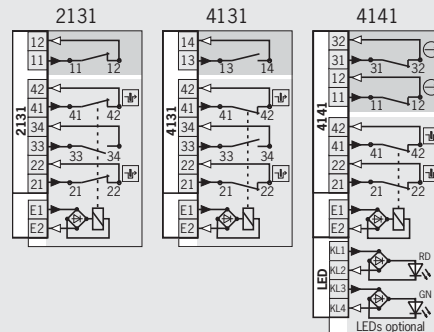

- Solenoid monitoring
- Door monitoring

For switching functions, see technical data on page 141



Cable entry M20 x 1.5

Dimension drawing

Mechanical release
Locking screw
LED indicator optional

Please order actuator separately (see page 96-99)
For cable glands, see page 108

Plug connector SR11 11-pin + PE

Mechanical release
Locking screw

Please order actuator separately (see page 96-99)
For plug connectors, see page 104

Wiring diagrams actuator inserted and locked

2131 4131 4141

LEDs optional

□ Solenoid monitoring
■ Door monitoring

For switching functions, see technical data on page 141

2131

LEDs optional

□ Solenoid monitoring
■ Door monitoring

For switching functions, see technical data on page 141

Ordering table

Series	Connection	Guard locking	Switching element	Version	Solenoid operating voltage		
					AC/DC 24 V		
STP-TW	M Cable entry 3 x M20 x 1.5	4 Electrical	2131 2 NC + 1 NO + 1 NC	With mechanical key release (identical locking)	100849 STP-TW-4A-2131AC024M		
			4131 2 NC + 1 NO + 1 NO		100850 STP-TW-4A-2131AC024M-S1		
			4141 2 NC + 2 NC		103910 STP-TW-4A-4131AC024M		
	SR11 Plug connector	3 Mechanical	2131 2 NC + 1 NO + 1 NC	024L LED indicator AC/DC 24 V	103636 STP-TW-4A-4141AC024L024M		
			2131 2 NC + 1 NO + 1 NC		106547 STP-TW-3A-2131AC024SR11		
			2131 2 NC + 1 NO + 1 NC		102565 STP-TW-4A-2131AC024SR11		

Selection table for safety switches STA with guard locking and guard locking monitoring

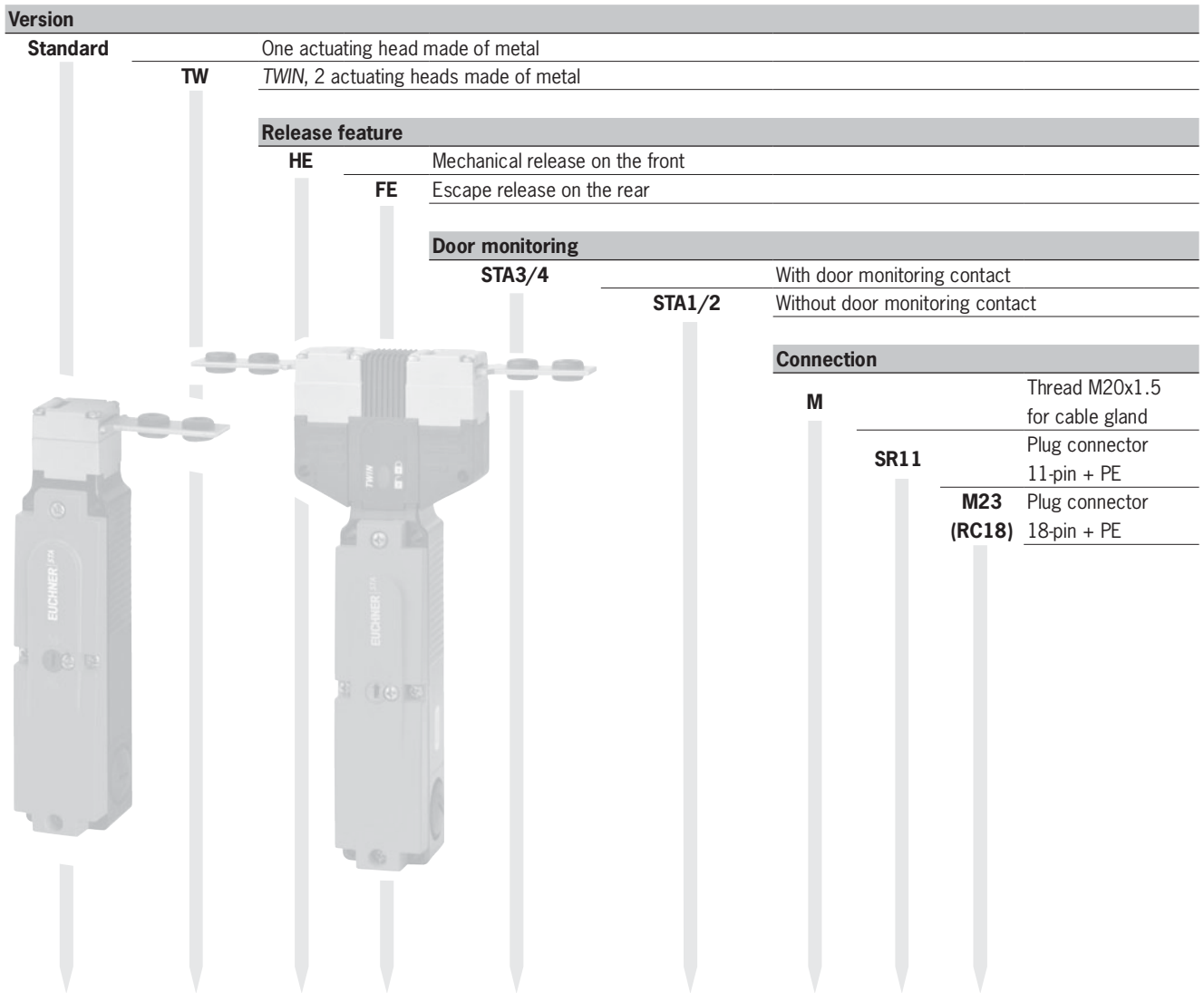

Version		Release feature		Door monitoring		Connection			Page
Standard	TW	HE	FE	STA3/4	STA1/2	M	SR11	M23 (RC18)	
●		●		●		●			76/77
●		●		●			●	●	78
●		●			●	●			79
●		●			●		●		80
●		●	●	●		●			81
	●	●		●		●			82

Safety switch STA with guard locking and guard locking monitoring



- ▶ Mechanical release on the front
- ▶ With door monitoring contact
- ▶ Plug connector optional



Approach direction



Horizontally and vertically adjustable in 90° steps

Mechanical release

Is used for releasing the guard locking with the aid of a tool. To protect against tampering, the mechanical release is sealed with sealing lacquer.

Solenoid operating voltage

- ▶ AC/DC 24 V +10%, -15%
- ▶ 230 V AC -15%, +10%

LED function display (optional)

A function display (2 LEDs, red and green) is available for the following voltage ranges:

- ▶ AC/DC 24 V +10%, -15%

Guard locking types

STA3 Closed-circuit current principle, guard locking by spring force. Release by applying voltage to the guard locking solenoid.

STA4 Open-circuit current principle, guard locking by applying voltage to the guard locking solenoid. Release by spring force.

Switching elements

- ▶ **2131** Slow-action switching contact
2 NC ⊕ + 1 NO + 1 NC (door monitoring contact)
- ▶ **4121** Slow-action switching contact
2 NC ⊕ + 1 NC / 1 NO (door monitoring contact)
- ▶ **4131** Slow-action switching contact
2 NC ⊕ + 1 NO + 1 NO (door monitoring contact)
- ▶ **4141** Slow-action switching contact
2 NC ⊕ + 2 NC ⊕ (door monitoring contact)

Cable entry M20 x 1.5

Dimension drawing

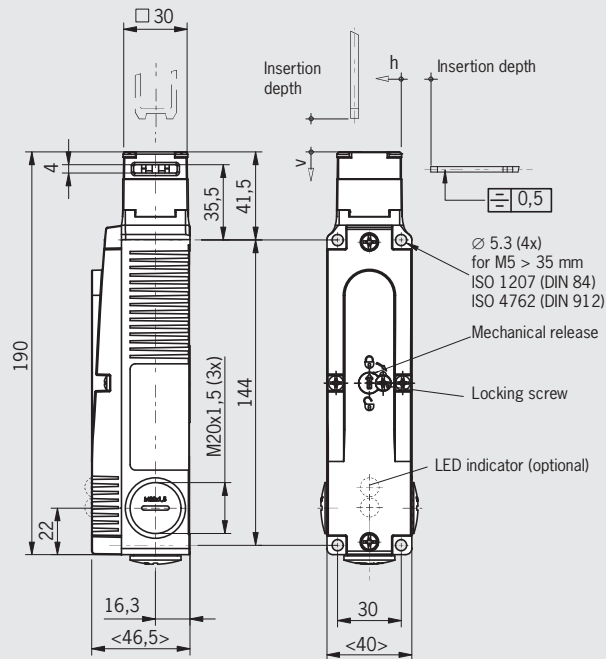

Please order actuator separately (see page 96-99)

For cable glands, see page 108

Wiring diagrams actuator inserted and locked

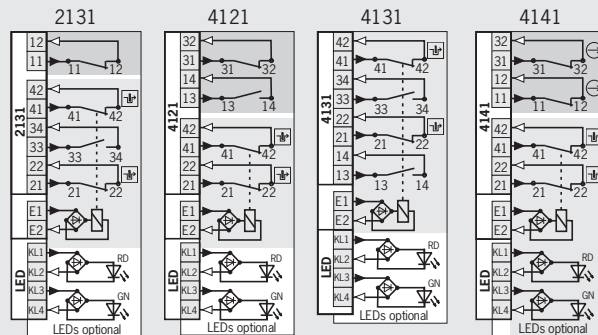

- Solenoid monitoring
- Door monitoring

For switching functions, see technical data on page 144

Ordering table

Series	Connection	Guard locking	Switching element	Version	Solenoid operating voltage	
					AC/DC 24 V	AC 230 V
STA	M Cable entry 3 x M20 x 1.5	3 Mechanical	2131 2 NC ⊕ + 1 NO + 1 NC	024L LED indicator AC/DC 24 V	096938 STA3A-2131A024M	104171 ¹⁾ STA3A-2131A230M
			4121 2 NC ⊕ + 1 NC / 1 NO		096936 STA3A-4121A024M	-
			4131 2 NC ⊕ + 1 NO + 1 NO		106535 STA3A-4121A024L024M	-
			4141 2 NC ⊕ + 2 NC ⊕		099480 STA3A-4131A024M	-
		4 Electrical	2131 2 NC ⊕ + 1 NO + 1 NC	024L LED indicator AC/DC 24 V	099274 STA3A-4141A024M	-
			4121 2 NC ⊕ + 1 NC / 1 NO		100898 STA3A-4141A024L024M	-
			4131 2 NC ⊕ + 1 NO + 1 NO		096939 STA4A-2131A024M	-
			4141 2 NC ⊕ + 2 NC ⊕		103926 STA4A-2131A024L024M	-
			096937 STA4A-4121A024M	-		
			099481 STA4A-4131A024M	-		
			109172 STA4A-4141A024M	-		

1) Only with solenoid operating voltage AC/DC 24 V



Cable entry M20 x 1.5

Dimension drawing

EX-version
with protective plate and protective sleeve

Labels in drawing: Protective plate, Cable gland M20x1.5 (included with EX version), Mechanical release, Locking screw, Insertion depth, h, v, 0.5, Ø 5.3 (4x) for M5 > 35 mm ISO 1207 (DIN 84) ISO 4762 (DIN 912).

Dimensions: 30, 4, 35.2, 41.2, 218, 52, 144, 30, 45, ca. 27.

Please order actuator separately (see page 96-99)

Please turn over

Wiring diagrams actuator inserted and locked

Models: 2131, 4121

LEDs optional

Solenoid monitoring
 Door monitoring

For switching functions, see technical data on page 144

Ordering table

Series	Connection	Guard locking	Switching element	Version	Solenoid operating voltage	
					AC/DC	24 V
STA	M Cable entry 3 x M20 x 1.5	3 Mechanical	2131 2 NC $\overline{+}$ + 1 NO + 1 NC	ATEX incl. cable gland	115584	STA3A-2131A024MF-EX
			4121 2 NC $\overline{+}$ + 1 NC / 1 NO	ATEX incl. cable gland	115586	STA3A-4121A024MF-EX
		4 Electrical	2131 2 NC $\overline{+}$ + 1 NO + 1 NC	ATEX incl. cable gland	115585	STA4A-2131A024MF-EX
			4121 2 NC $\overline{+}$ + 1 NC / 1 NO	ATEX incl. cable gland	123076	STA4A-4121A024MF-EX

1) II 3 G Ex nR IIB T4 Gc / II 3 D Ex tc IIIC T110° Dc X

For technical data, see page 121



Plug connector SR11 11-pin + PE

Dimension drawing

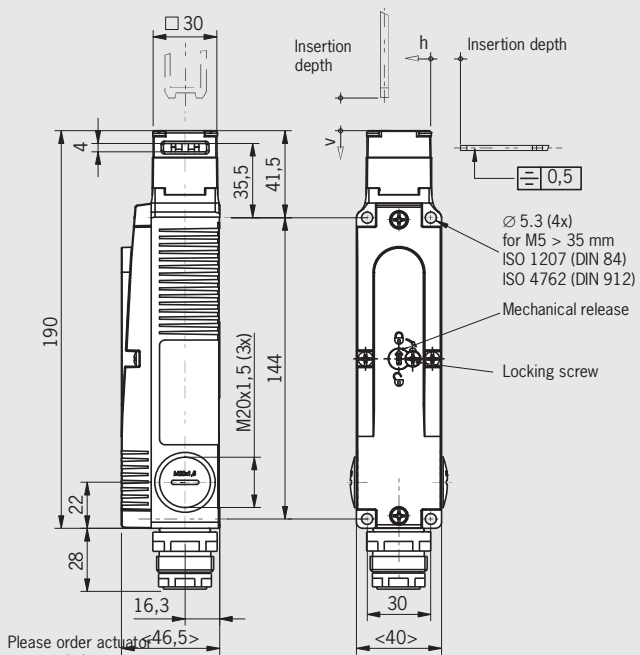

Please order actuator separately (see page 96-99)

For plug connectors, see page 104

Plug connector M23 (RC18) 18-pin + PE

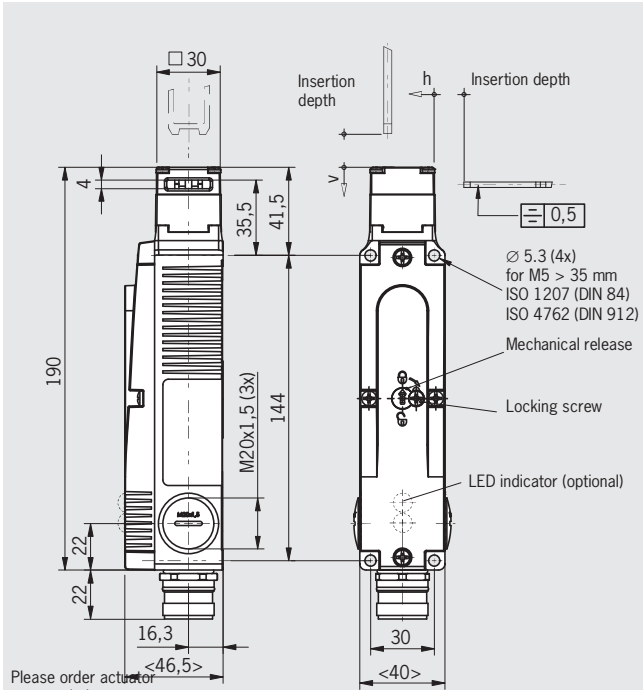

Please order actuator separately (see page 96-99)

For plug connectors, see page 105/106

Wiring diagrams actuator inserted and locked

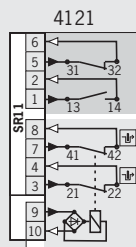

- Solenoid monitoring
- Door monitoring

For switching functions, see technical data on page 144

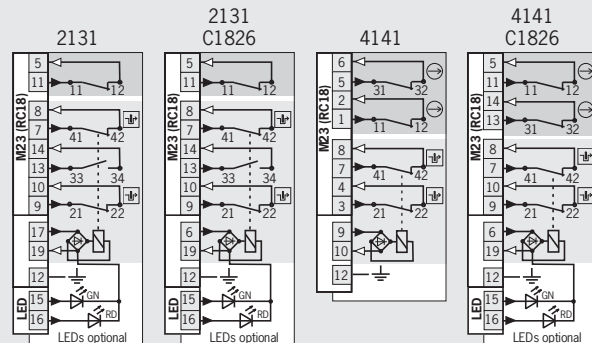

- Solenoid monitoring
- Door monitoring

For switching functions, see technical data on page 144

Ordering table

Series	Connection	Guard locking	Switching element	Version	Solenoid operating voltage
					AC/DC 24 V
STA	SR11 Plug connector	3 Mechanical	4121 2 NC $\overline{+}$ + 1 NC / 1 NO		105304 STA3A-4121A024SR11
					099658 STA3A-2131A024L024RC18
	M23 (RC18) Plug connector	3 Mechanical	2131 2 NC $\overline{+}$ + 1 NO + 1 NC		106623 STA3A-2131A024L024RC18C1826
					100029 STA3A-4141A024RC18
		4 Electrical	2131 2 NC $\overline{+}$ + 1 NO + 1 NC		114416 STA3A-4141A024L024RC18C1826
					105303 STA4A-2131A024L024RC18
				106622 STA4A-2131A024L024RC18C1826	

Safety switch STA with guard locking and guard locking monitoring



- ▶ Mechanical release on the front
- ▶ Without door monitoring contact
- ▶ Plug connector optional



Approach direction



Horizontally and vertically adjustable in 90° steps

Mechanical release

Is used for releasing the guard locking with the aid of a tool. To protect against tampering, the mechanical release is sealed with sealing lacquer.

Solenoid operating voltage

- ▶ AC/DC 24 V +10%, -15%

Guard locking types

STA1 Closed-circuit current principle, guard locking by spring force. Release by applying voltage to the guard locking solenoid.

STA2 Open-circuit current principle, guard locking by applying voltage to the guard locking solenoid. Release by spring force.

Switching elements

- ▶ **4131** Slow-action switching contact
2 NC ⊖ + 2 NO

Cable entry M20 x 1.5

Dimension drawing

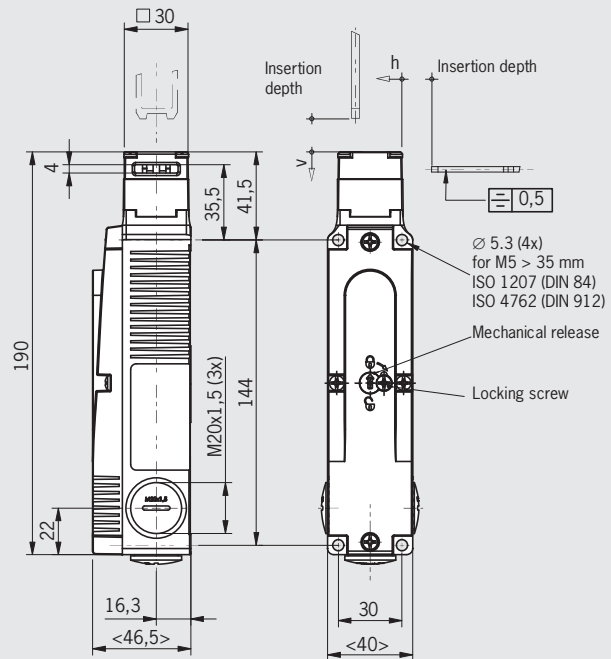

Please order actuator separately (see page 96-99)

For cable glands, see page 108

Wiring diagrams actuator inserted and locked

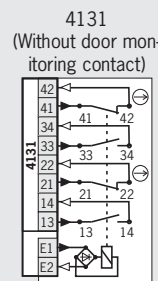

For switching functions, see technical data on page 143

Ordering table

Series	Connection	Guard locking	Switching element	Solenoid operating voltage	
				AC/DC 24 V	
STA	M Cable entry 3 x M20 x 1.5	1 Mechanical	4131 2 NC ⊖ + 2 NO	096439	STA1A-4131A024M
		2 Electrical	4131 2 NC ⊖ + 2 NO	096935	STA2A-4131A024M



Plug connector SR11 11-pin + PE

Dimension drawing

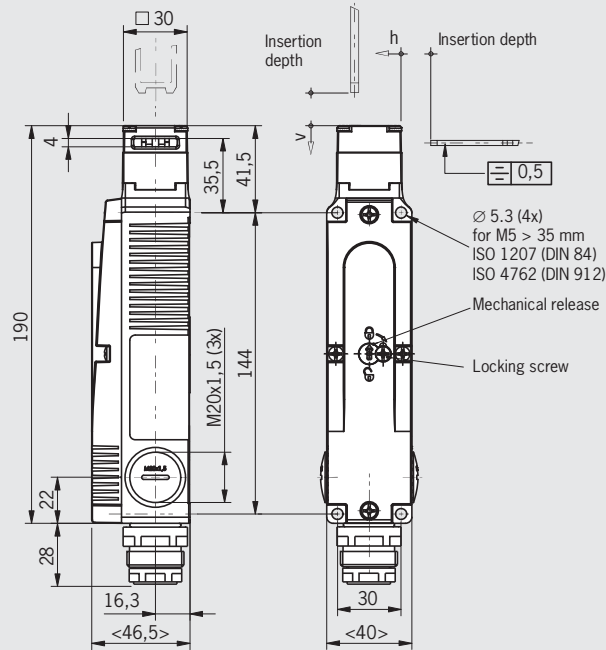

Please order actuator separately (see page 96-99)

For plug connectors, see page 104

Wiring diagrams actuator inserted and locked

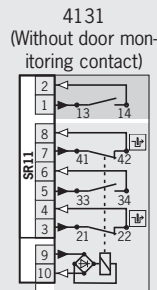

For switching functions, see technical data on page 143

- Solenoid monitoring
- Door monitoring

Ordering table

Series	Connection	Guard locking	Switching element	Version	Solenoid operating voltage
					AC/DC 24 V
STA	SR11 Plug connector	2 Electrical	4131 2 NC + 2 NO		109574 STA2A-4131A024SR11

Safety switch STA with guard locking and guard locking monitoring



- ▶ Escape release from the rear
- ▶ With door monitoring contact

Cable entry M20 x 1.5



Approach direction



Horizontally and vertically adjustable in 90° steps

Escape release

This is used for manual release of guard locking from within the danger zone without tools. With identification of On/Off position.

Solenoid operating voltage

- ▶ AC/DC 24 V +10%, -15%

Guard locking types

STA3 Closed-circuit current principle, guard locking by spring force. Release by applying voltage to the guard locking solenoid.

Switching elements

- ▶ **2131** Slow-action switching contact
2 NC ⊖ + 1 NO + 1 NC (door monitoring contact)

Dimension drawing

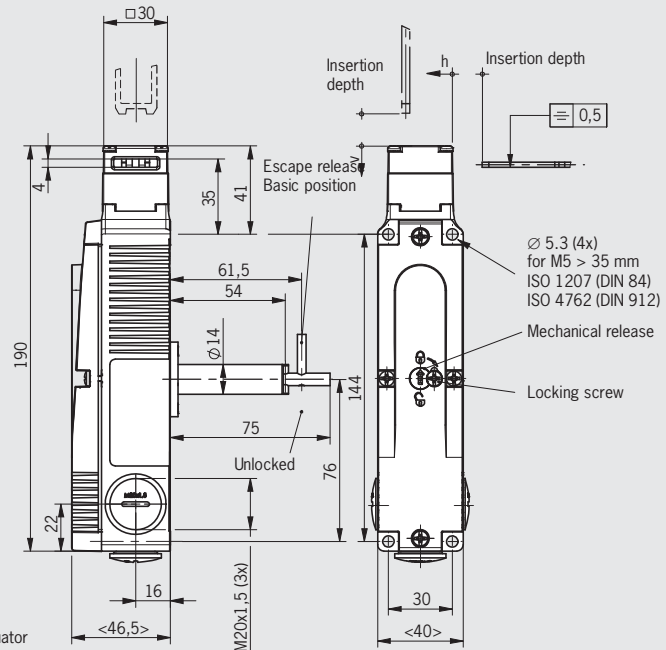

Wiring diagrams actuator inserted and locked

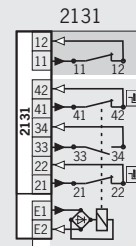

- Solenoid monitoring
- Door monitoring

For switching functions, see technical data on page 144

Ordering table

Series	Connection	Guard locking	Switching element	Version	Solenoid operating voltage	
					AC/DC	24 V
STA	M Cable entry 3 x M20 x 1.5	3 Mechanical	2131 2 NC ⊖ + 1 NO + 1 NC	C1993 Long actuator shaft	103660	STA3A-2131A024MC1993



Safety switch STA-TW with guard locking and guard locking monitoring

- ▶ Actuating heads made of metal
- ▶ Simultaneous monitoring of two safety doors
- ▶ Mechanical release on the front
- ▶ Mechanical key release optional
- ▶ With door monitoring contact



Approach direction



Horizontally and vertically adjustable in 90° steps

Mechanical release

Is used for releasing the guard locking with the aid of a tool. To protect against tampering, the mechanical release is sealed with sealing lacquer.

Mechanical key release

Additional lock on the switch head. Function as for mechanical release. The mechanical key release setting is indicated in the window. Two keys are included.

Solenoid operating voltage

- ▶ AC/DC 24 V +10%, -15%

LED function display (optional)

A function display (2 LEDs, red and green) is available for the following voltage ranges:

- ▶ AC/DC 24 V +10%, -15%

Guard locking types

STP3 Closed-circuit current principle, guard locking by spring force. Release by applying voltage to the guard locking solenoid.

Switching elements

- ▶ **2131** Slow-action switching contact
2 NC \ominus + 1 NO + 1 NC (door monitoring contact)
- ▶ **4121** Slow-action switching contact
2 NC \ominus + 1 NC / 1 NO (door monitoring contact)

Cable entry M20 x 1.5

Dimension drawing

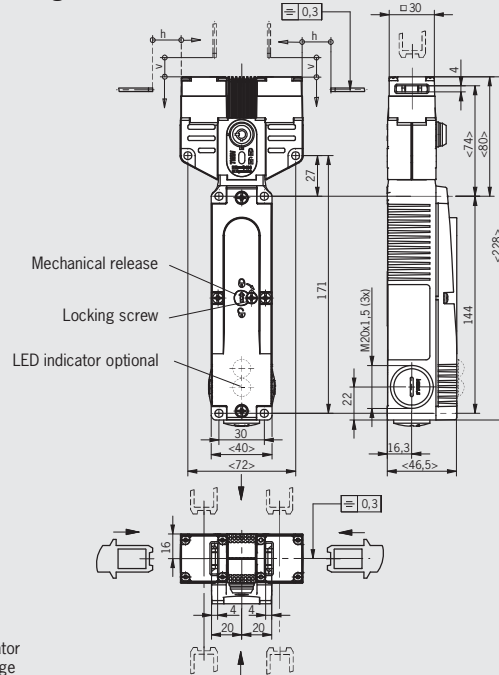

For cable glands, see page 108

Wiring diagrams actuator inserted and locked

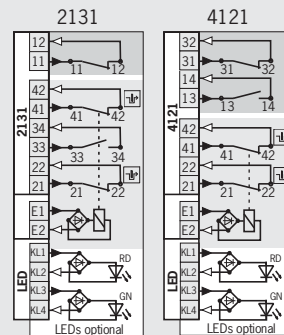

For switching functions, see technical data on page 146

- Solenoid monitoring
- Door monitoring

Ordering table

Series	Connection	Guard locking	Switching element	Version	Solenoid operating voltage	
					AC/DC 24 V	
STA-TW	M Cable entry 3 x M20 x 1.5	3 Mechanical	2131 2 NC \ominus + 1 NO + 1 NC		105617 STA-TW-3A-2131AC024M	
				With mechanical key re- lease (identical locking)	105888 STA-TW-3A-2131AC024M-S1	
			4121 2 NC \ominus + 1 NC / 1 NO		106545 STA-TW-3A-4121AC024M	
				024L LED indicator AC/DC 24 V	106379 STA-TW-3A-4121AC024L024M	

Selection table for safety switches STM with guard locking and guard locking monitoring

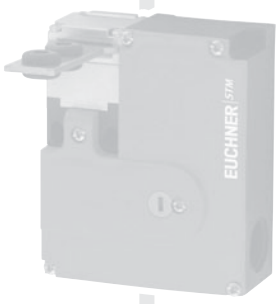
Release feature, front			
HE	Mechanical release on the front		
	Connection		
	M	Thread M20x1.5 for cable glands	
	Switching element		
	3 contacts	1 NC ⊖ (ÜK) + 2 NC ⊖ (SK) or 1 NC ⊖ (ÜK) + 1 NC ⊖ (SK) + 1 NO (SK)	
Manual release HE	Connection M	Switching element 3 contacts	Page
●	●	●	84

Safety switch STM with guard locking and guard locking monitoring



- ▶ Actuating head optionally made of metal or plastic
- ▶ Mechanical release on the front



Approach direction



Horizontally and vertically adjustable in 90° steps

Mechanical release

Is used for releasing the guard locking with the aid of a tool. To protect against tampering, the mechanical release is sealed with sealing lacquer.

Solenoid operating voltage

- ▶ AC/DC 24 V +10%, -15%
- ▶ AC 230 V +10%, -15%

LED function display (optional)

A function display (1 LED, green) is available for the following voltage ranges:

- ▶ AC/DC 24 V +10%, -15%

Guard locking types

STM1 Closed-circuit current principle, guard locking by spring force. Release by applying voltage to the guard locking solenoid.

STM2 Open-circuit current principle, guard locking by applying voltage to the guard locking solenoid. Release by spring force.

Switching elements

ÜK For monitoring the guard locking (builtin solenoid)
Slow-action switching contact 1 NC

SK For monitoring the door/actuator position

222 Slow-action switching contact
2 NC

242 Slow-action switching contact
1 NC + 1 NO

Cable entry M20 x 1.5

Dimension drawing

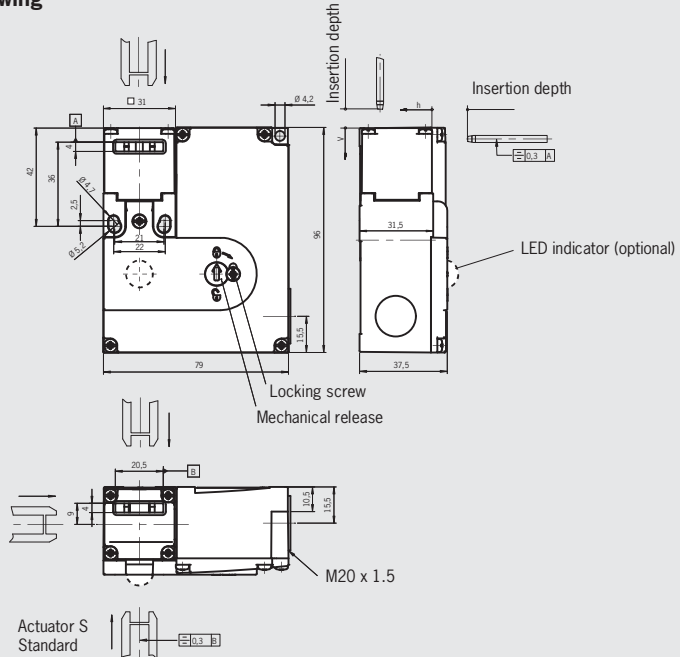

Please order actuator separately (see page 96-99)

For cable glands, see page 108

Wiring diagrams actuator inserted and locked

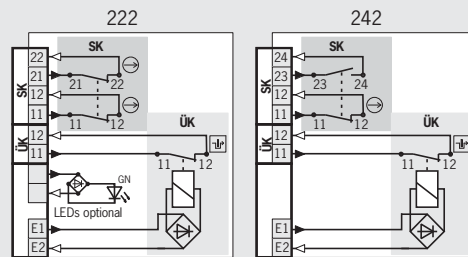

- Solenoid monitoring
- Door monitoring

For switching functions, see technical data on page 148

Ordering table

Series	Connection	Guard locking	Actuating head	Switching element	Version	Solenoid operating voltage	
						AC/DC 24 V	AC 230 V
STM	Cable entry 1 x M20 x 1.5	1 Mechanical	N Plastic	ÜK: 1 NC $\overline{\text{NF}}$ SK: 222 , 2 NC \ominus		091865 STM1N-222B024-M	098714 STM1N-222B230-M
				ÜK: 1 NC $\overline{\text{NF}}$ SK: 242 , 1 NC \ominus + 1 NO		092031 STM1N-242B024-M	-
				ÜK: 1 NC $\overline{\text{NF}}$ SK: 222 , 2 NC \ominus		095396 STM1A-222B024-M	098036 STM1A-222B230-M
			A Metal	ÜK: 1 NC $\overline{\text{NF}}$ SK: 222 , 2 NC \ominus	C2160	098856 STM1A-222B024-MC2160	
				ÜK: 1 NC $\overline{\text{NF}}$ SK: 242 , 1 NC \ominus + 1 NO	LED indicator AC/DC 24 V	095397 STM1A-242B024-M	
				ÜK: 1 NC $\overline{\text{NF}}$ SK: 222 , 2 NC \ominus		092048 STM2N-222B024-M	
		2 Electrical	N Plastic	ÜK: 1 NC $\overline{\text{NF}}$ SK: 222 , 2 NC \ominus		092050 STM2N-242B024-M	
				ÜK: 1 NC $\overline{\text{NF}}$ SK: 242 , 1 NC \ominus + 1 NO		095398 STM2A-222B024-M	
				ÜK: 1 NC $\overline{\text{NF}}$ SK: 222 , 2 NC \ominus		095399 STM2A-242B024-M	
			A Metal	ÜK: 1 NC $\overline{\text{NF}}$ SK: 222 , 2 NC \ominus		095399 STM2A-242B024-M	
				ÜK: 1 NC $\overline{\text{NF}}$ SK: 242 , 1 NC \ominus + 1 NO			
				ÜK: 1 NC $\overline{\text{NF}}$ SK: 222 , 2 NC \ominus			

1) Only with solenoid operating voltage AC/DC 24 V

Selection table for safety switch TK with guard locking (without failsafe locking mechanism)

Release feature					
HE	Mechanical release on the switch head				
Guard locking pin					
	A	C	Right		
			Left		
Connection					
			M	Thread M20x1.5 for cable gland	
			SM8	Plug connector M12, 8-pin	
					
Release feature HE	Guard locking pin		Connection		Page
	A	C	M	SM8	
●	●		●		86
●		●	●	●	87

Safety switch TK with guard locking (without failsafe locking mechanism)



- ▶ Mounting on plastic housing TP with actuating head and guard locking pin made of metal
- ▶ High locking forces of well above 5,000 N
- ▶ Mechanical release on the switch head
- ▶ Actuating element for auxiliary shut-down on front
- ▶ Cable entry M20 x 1.5



Function

Guard locking is by movement of the locking pin, which is inserted in a "recess."

Mechanical release

This releases the guard locking after operation with a triangular key (DIN 22417). For triangular key see accessories, page 108.

auxiliary shutdown feature

When actuated, positively driven contacts 21-22 or 41-42 are opened. The guard remains locked. The auxiliary shutdown feature must be sealed to prevent tampering (for example with sealing lacquer).

Solenoid operating voltage

- ▶ AC/DC 24 V +10%, -15%
- ▶ AC 230 V +10%, -15%

Guard locking types

TK1 Closed-circuit current principle, guard locking by spring force. Release by applying voltage to the guard locking solenoid.

TK2 Open-circuit current principle, guard locking by applying voltage to the guard locking solenoid. Release by spring force.

Switching elements

- ▶ **528** Slow-action switching contact
1 NC ⊖ + 1 NO
- ▶ **4131** Slow-action switching contact
2 NC ⊖ + 2 NO

Ordering table

Series	Connection	Guard locking	Switching element	Version	Solenoid operating voltage
					AC/DC 24 V
TK	M Cable entry 3 x M20 x 1.5	1 Mechanical	528 1 NC ⊖ + 1 NO	A Guard locking pin right	094652 TK1-528AB024M
			4131 2 NC ⊖ + 2 NO	A Guard locking pin right	099686 TK1-4131AB024M
		2 Electrical	4131 2 NC ⊖ + 2 NO	A Guard locking pin right	099690 TK2-4131AB024M

Cable entry M20 x 1.5
Guard locking pin right

Dimension drawing

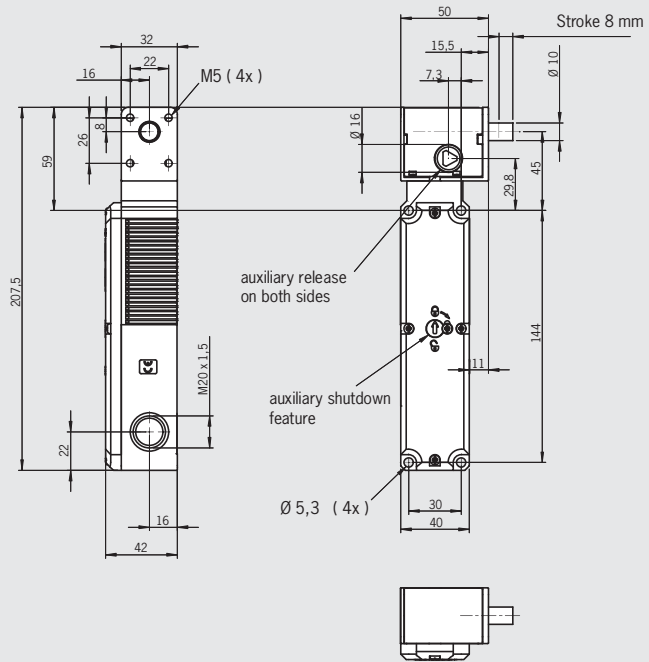

For cable glands, see page 108

Wiring diagrams switch locked

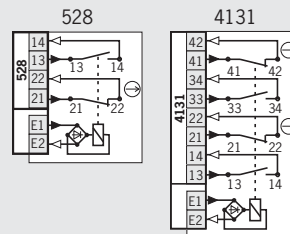

For switching functions, see technical data on page 150



Cable entry M20 x 1.5 Guard locking pin left

Plug connector SM8 Plug M12, 8-pin, guard locking pin left

Dimension drawing

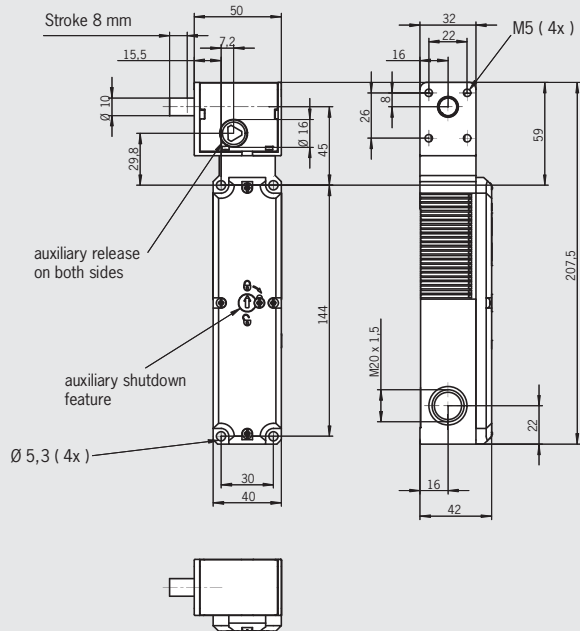

For cable glands, see page 108

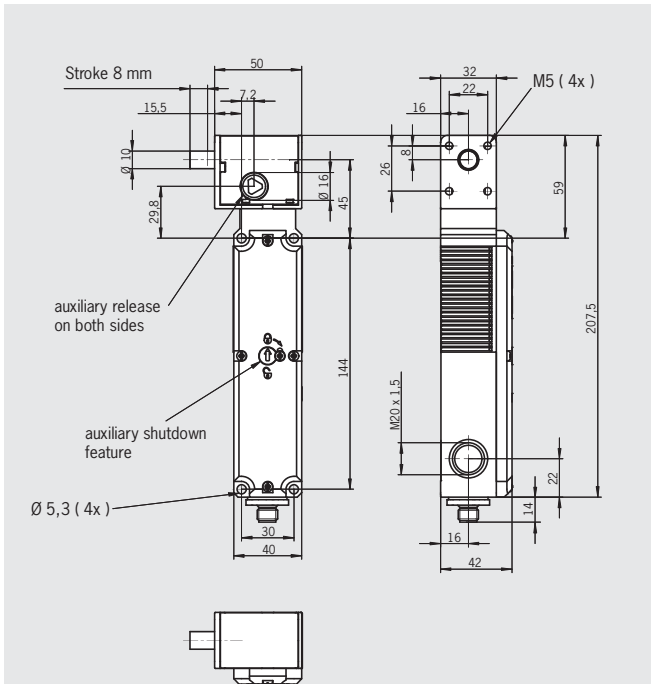

For plug connectors, see page 103

Wiring diagrams switch locked

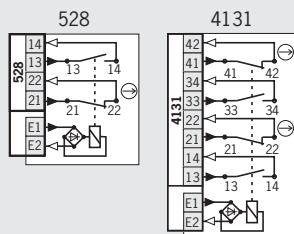

For switching functions, see technical data on page 150

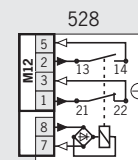

For switching functions, see technical data on page 150

Ordering table

Series	Connection	Guard locking	Switching element	Version	Solenoid operating voltage	
					AC/DC 24 V	AC 230 V
TK	M Cable entry 3 x M20 x 1.5	1 Mechanical	528 1 NC ⊖ + 1 NO	C Guard locking pin left	094192 TK1-528CB024M	100016 TK1-528CB230M
			4131 2 NC ⊖ + 2 NO	C Guard locking pin left	099687 TK1-4131CB024M	-
		2 Electrical	4131 2 NC ⊖ + 2 NO	C Guard locking pin left	099691 TK2-4131CB024M	-
	SM8 Plug connector M12	1 Mechanical	528 1 NC ⊖ + 1 NO	C Guard locking pin left	122828 TK1-528CB024SM8	-

1) Only with solenoid operating voltage AC/DC 24 V

For technical data, see page 121

Selection table for accessories

Actuator													
Insertion funnel													
Mounting plates/mounting brackets													
Connection													
M12													
SR6													
SR11													
M23 (RC18)													
BHA12													
Cable glands													
LED displays													
Miscellaneous													
Bolts for guards													
Actuator	Insertion funnel	Mounting plates/mounting brackets	Plug connector					Cable glands	LED displays	Miscellaneous	Bolts		Page
			M12	SR6	SR11	M23 (RC18)	BHA12				Metal	Plastic	
•													90 - 99
	•												100
		•											101 / 102
			•										103
				•									104
					•								104
						•							105 / 106
							•						107
								•					108
									•				108
										•			109 - 111
											•		112 - 117
												•	118

Actuators for safety switches NM.VZ

- ▶ Actuators made of stainless steel
- ▶ Two stainless safety screws per actuator
- ▶ Actuators with optional rubber bushings
- ▶ Compact design optional

Straight actuator

The straight actuator is used on sliding doors or hinged doors with door radii greater than 150 mm. Safety screws prevent unscrewing of the actuator.

Actuator with rubber bush

For flexible mounting of the actuator.

Screws made of stainless steel

The safety screws included can be inserted with a normal tool, but cannot be removed again.

Actuator M-G straight
overtravel 4 mm

Dimension drawings

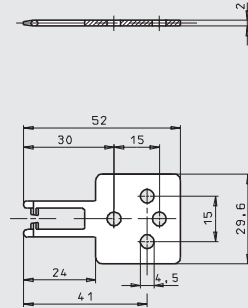

Actuator M-W bent
overtravel 4 mm

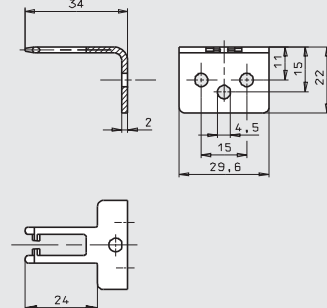

Actuator M-GT straight
Longitudinal rubber bush,
overtravel 4 mm

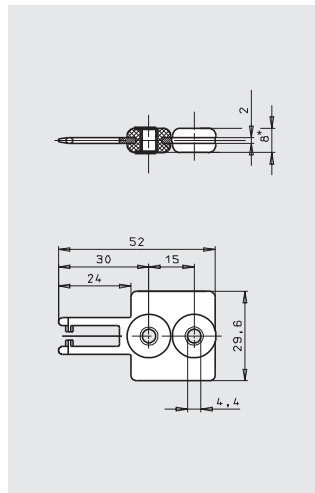

Actuator M-GQ straight
Transverse rubber bush,
overtravel 4 mm

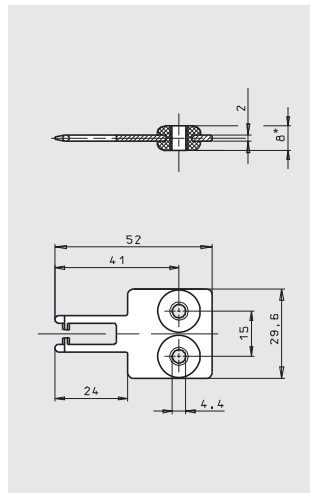

Actuator M-WT bent
Rubber bush, overtravel 4 mm

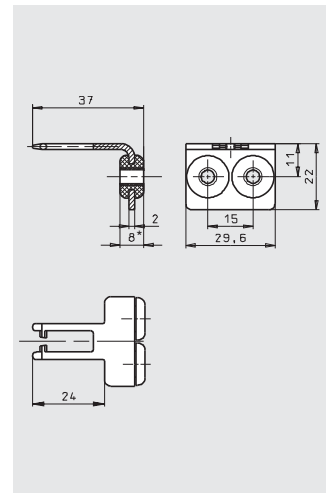

Ordering table

Designation	Version	Min. door radius r [mm]	Packaging unit	Order no.
Actuator Straight	M-G overtravel 4 mm incl. 2 safety screws M4 x 14		1 pcs.	074076 ACTUATOR-M-G
Actuator Angled	M-W overtravel 4 mm incl. 2 safety screws M5 x 10		1 pcs.	074077 ACTUATOR-M-W
Actuator Straight longitudinal rubber bush	M-GT overtravel 4 mm incl. 2 safety screws M4 x 14		1 pcs.	074078 ACTUATOR-M-GT
Actuator Straight transverse rubber bush	M-GQ overtravel 4 mm incl. 2 safety screws M4 x 14		1 pcs.	074079 ACTUATOR-M-GQ
Actuator Angled rubber bush	M-WT overtravel 4 mm incl. 2 safety screws M4 x 14		1 pcs.	074080 ACTUATOR-M-WT

Actuator M-GS straight
Narrow, overtravel 4 mm

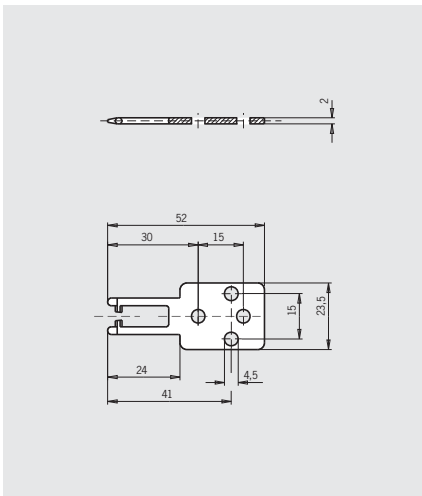

Actuator M-WS bent
Narrow, overtravel 4 mm

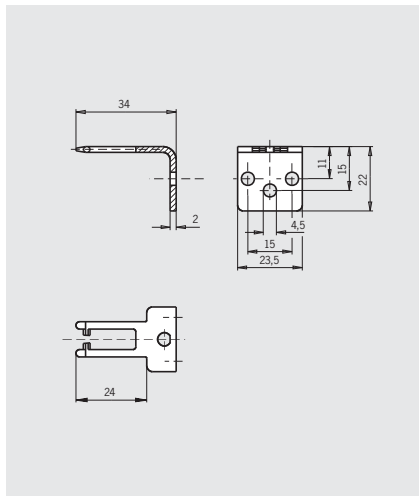

Actuator M-GTS straight
Rubber bush, narrow, overtravel 4 mm

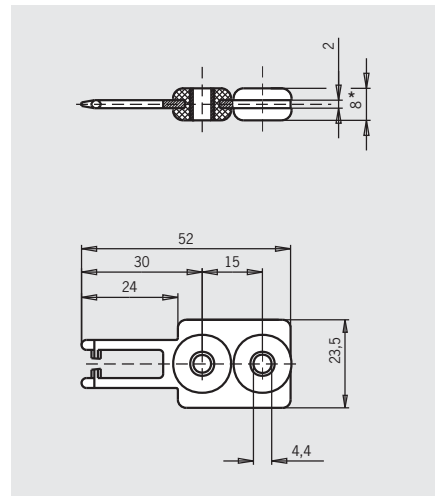

Ordering table

Designation	Version	Min. door radius r [mm]	Packaging unit	Order no.
Actuator Straight narrow	M-GS overtravel 4 mm incl. 2 safety screws M4 x 14		1 pcs.	074128 ACTUATOR-M-GS
Actuator Angled narrow	M-WS 4 mm overtravel incl. 2 safety screws M5 x 10		1 pcs.	074129 ACTUATOR-M-WS
Actuator straight, narrow rubber bush	M-GTS overtravel 4 mm incl. 2 safety screws M4 x 14		1 pcs.	074130 ACTUATOR-M-GTS

Actuators for safety switches NP/GP/TP

- ▶ Actuators made of stainless steel
- ▶ Two stainless safety screws per actuator
- ▶ Actuators with optional rubber bushings

Straight actuator

The straight actuator is used on sliding doors or hinged doors with door radii greater than 1,000 mm. Safety screws prevent unscrewing of the actuator.

Actuator with overtravel

- ▶ 2 mm for doors with normal play
- ▶ 7 mm for doors with large play (optional)

Actuator with rubber bush

For flexible mounting of the actuator.

Screws made of stainless steel

The safety screws included can be inserted with a normal tool, but cannot be removed again.

Actuator P-G straight
overtravel 2 mm

Dimension drawings

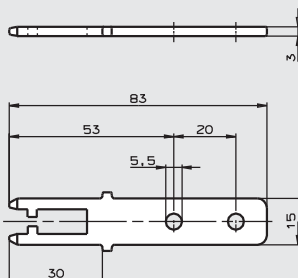

Actuator P-W bent
overtravel 2 mm

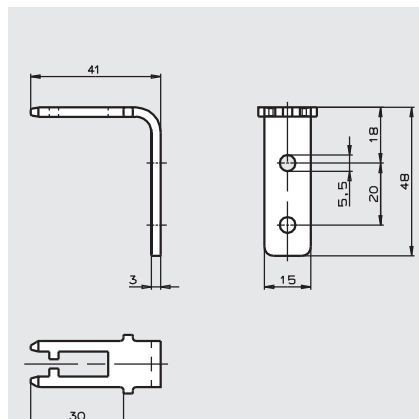

Actuator P-GN straight
overtravel 7 mm

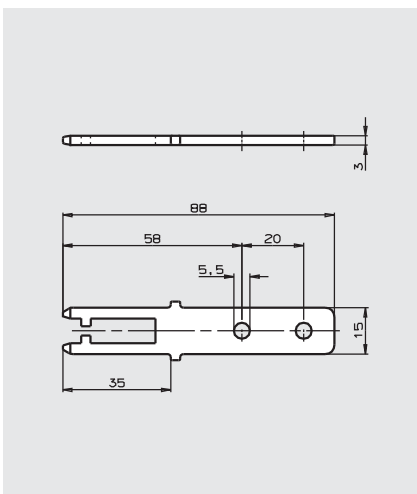

Actuator P-WN bent
overtravel 7 mm

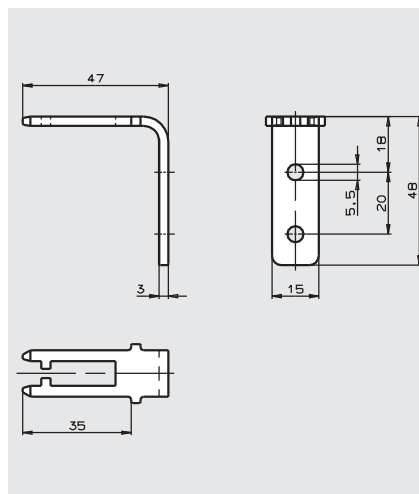

Ordering table

Designation	Version	Min. door radius r [mm]	Packaging unit	Order no.
Actuator Straight	P-G overtravel 2 mm incl. 2 safety screws M5 x 10	1,000	1 pcs.	059226 Actuator-P-G
Actuator Angled	P-W overtravel 2 mm incl. 2 safety screws M5 x 10	1,000	1 pcs.	059227 ACTUATOR-P-W
Actuator Straight Overtravel	P-GN overtravel 7 mm incl. 2 safety screws M5 x 10	1,000	1 pcs.	074570 Actuator-P-GN
Actuator Angled Overtravel	P-WN overtravel 7 mm incl. 2 safety screws M5 x 10	1,000	1 pcs.	074571 Actuator-P-WN

Actuator P-GT straight
Rubber bush, overtravel 2 mm

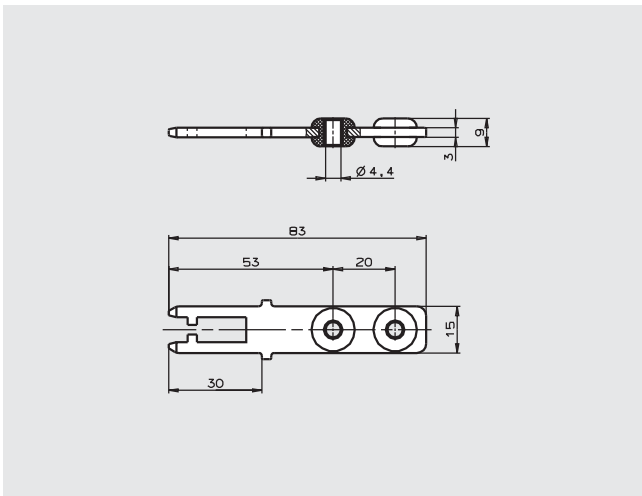

Actuator P-WT bent
Rubber bush, overtravel 2 mm

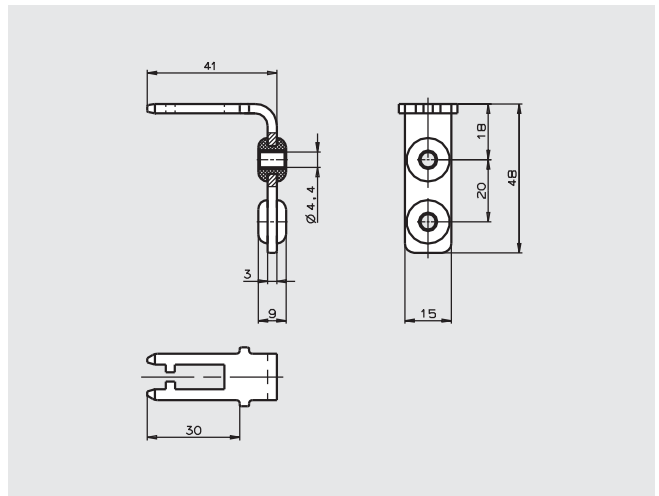

Actuator P-GNT straight
Rubber bush, overtravel 7 mm

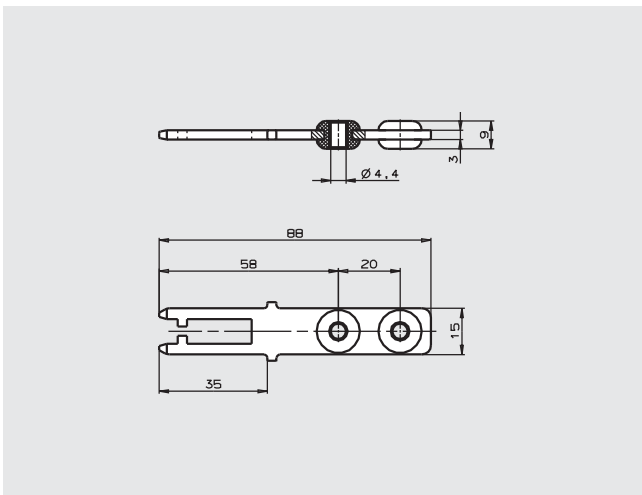

Actuator P-WNT bent
Rubber bush, overtravel 7 mm

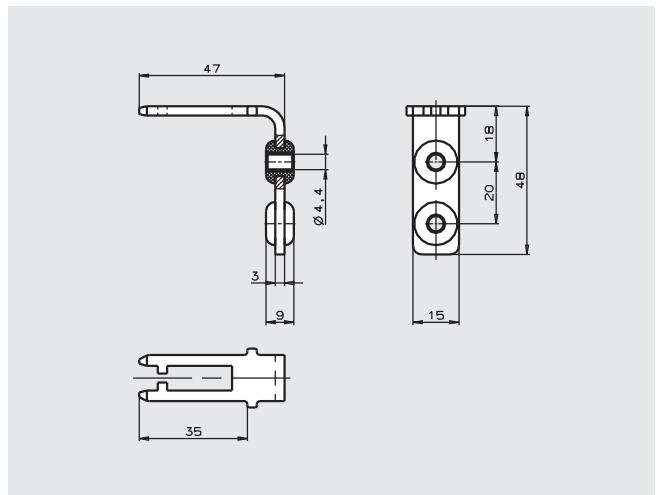

Ordering table

Designation	Version	Min. door radius r [mm]	Packaging unit	Order no.
Actuator Straight rubber bush	P-GT overtravel 2 mm incl. 2 safety screws M4 x 14	1,000	1 pcs.	070046 Actuator-P-GT
Actuator Angled rubber bush	P-WT overtravel 2 mm incl. 2 safety screws M4 x 14	1,000	1 pcs.	070038 Actuator-P-WT
Actuator Straight rubber bush, overtravel	P-GNT overtravel 7 mm incl. 2 safety screws M4 x 14	1,000	1 pcs.	074576 Actuator-P-GN
Actuator Angled rubber bush, overtravel	P-WNT overtravel 7 mm incl. 2 safety screws M4 x 14	1,000	1 pcs.	074577 Actuator-P-WNT

Hinged actuators for safety switches NP/GP/TP

- ▶ Actuators made of stainless steel
- ▶ Two stainless safety screws per actuator
- ▶ For doors hinged at top and bottom
- ▶ For doors hinged on the right and left

Hinged actuator

For door radii less than 1,000 mm a hinged actuator should be used. The spring action movement of the actuator prevents damage resulting from the actuator jamming in the actuating head. Depending on the movement of the guard, the actuator must be selected for left/right or top/bottom.

Hinged actuator P-OU

Guard hinged at top/bottom, overtravel 2 mm

Dimension drawings

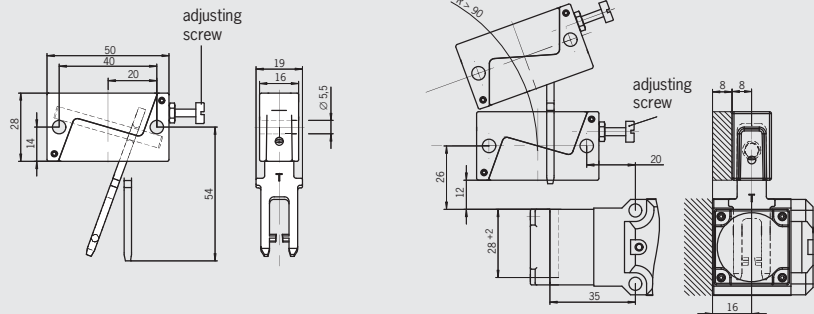

Hinged actuator P-LR

Guard hinged on left/right, overtravel 2 mm

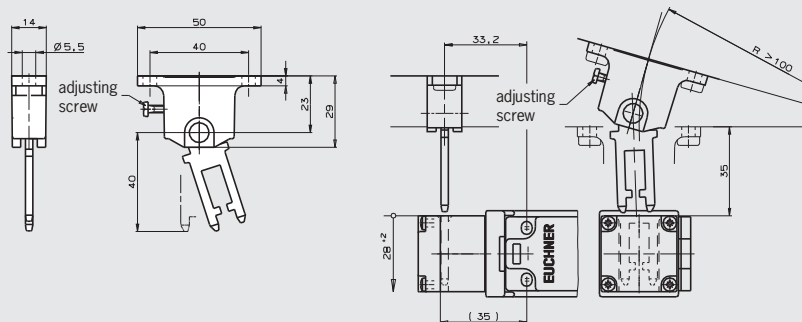

Ordering table

Designation	Version	Min. door radius r [mm]	Packaging unit	Order no.
Hinged actuator	P-OU For doors hinged at top and bottom overtravel 2 mm incl. 2 safety screws M5 x 25	90	1 pcs.	070050 HINGED ACTUATOR P-OU
	P-LR For doors hinged on the left and right overtravel 2 mm incl. 2 safety screws M5 x 10	100	1 pcs.	059440 HINGED ACTUATOR P-LR

Hinged actuator P-OUN

Guard hinged at top/bottom, overtravel 7 mm

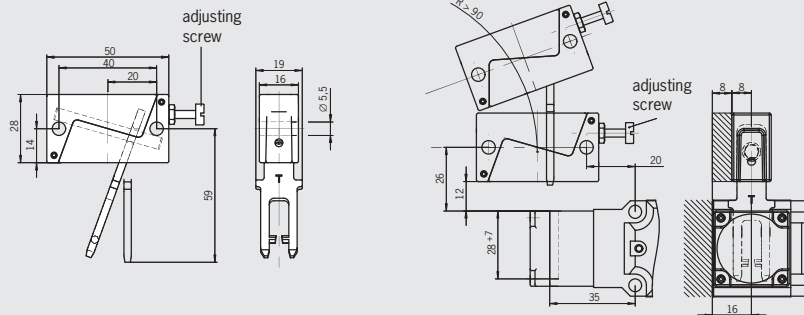

Hinged actuator P-LRN

Guard hinged on left/right, overtravel 7 mm

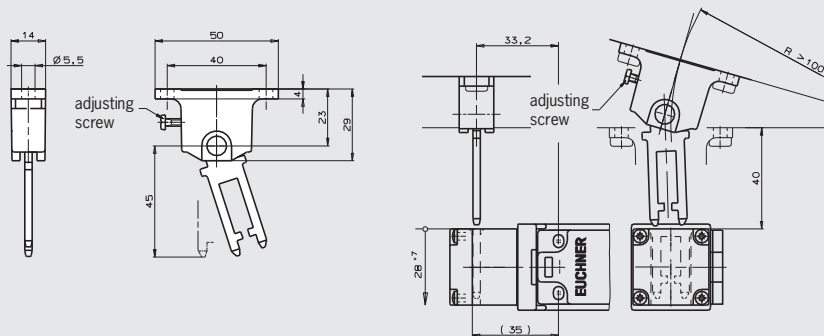

Ordering table

Designation	Version	Min. door radius r [mm]	Packaging unit	Order no.
Hinged actuator	P-OUN For doors hinged at top and bottom overtravel 7 mm incl. 2 safety screws M5 x 25	90	1 pcs.	074572 HINGED ACTUATOR P-OUN
	P-LRN For doors hinged on the left and right overtravel 7 mm incl. 2 safety screws M5 x 10	100	1 pcs.	074573 HINGED ACTUATOR P-LRN

Actuators for safety switches SGA/SGP/STA/STP/STM

- ▶ Two stainless safety screws per actuator
- ▶ Actuators with and without rubber bush

Notice

Type S actuators must not be used in conjunction with insertion funnels.

L actuators must be used for insertion funnels.

Straight actuator

Suitable for a maximum tensile force of 2,500 N for STP, or 3,000 N for STA.

The straight actuator is used on sliding doors or hinged doors with door radii greater than 300 mm. Safety screws prevent unscrewing of the actuator.

Bent actuator

Suitable for a maximum tensile force of 1500 N.

Screws made of stainless steel

The safety screws included can be inserted with a normal tool, but cannot be removed again.

Actuator S standard straight (physically compatible with TP actuator P-G)
Without rubber bush, overtravel 5 mm

Dimension drawings

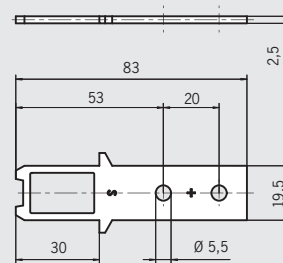

Standard actuator S, straight
With rubber bush, overtravel 5 mm

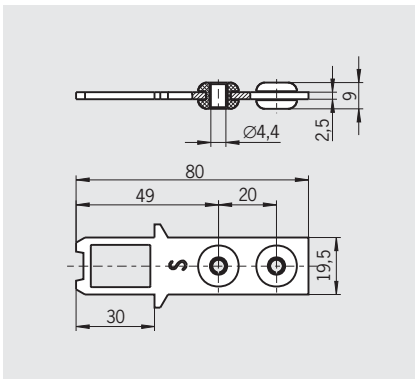

Standard actuator S, bent
With rubber bush, overtravel 5 mm

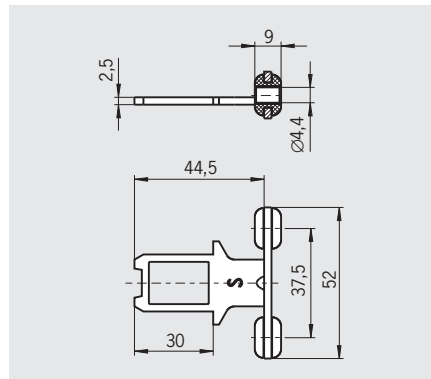

Actuator L, straight, for insertion funnel
With rubber bush, overtravel 5 mm

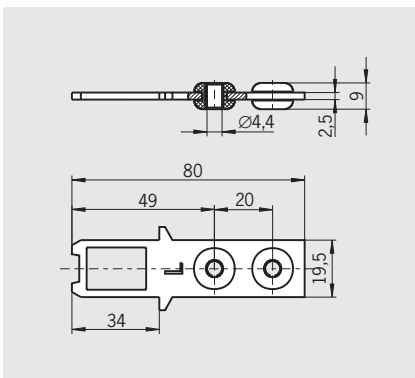

Actuator L, bent, for insertion funnel
With rubber bush, overtravel 5 mm

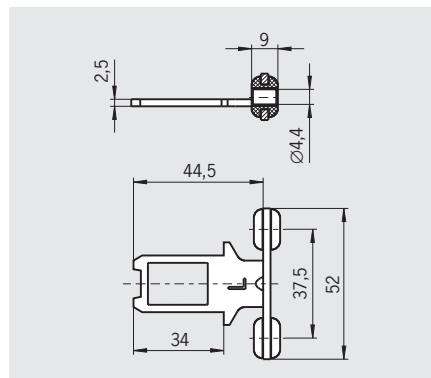

Ordering table

Designation	Version	Min. door radius r [mm]	Packaging unit	Order no.
Actuator S Straight	S-G-SN-C2115 Without rubber bush, overtravel 5 mm incl. 2 safety screws M5 x 10	300	1 pcs.	097861 ACTUATOR S-G-SN-C2115
	S-GT-SN With rubber bush, overtravel 5 mm incl. 2 safety screws M4 x 14	300	1 pcs.	095738 ACTUATOR S-GT-SN
Actuator S Angled	S-WQ-SN With rubber bush, overtravel 5 mm incl. 2 safety screws M4 x 14	300	1 pcs.	095740 ACTUATOR S-WQ-SN
Actuator L Straight	S-GT-LN With rubber bush, overtravel 5 mm incl. 2 safety screws M4 x 14	300	1 pcs.	095739 ACTUATOR S-GT-LN
Actuator L Angled	S-WQ-LN With rubber bush, overtravel 5 mm incl. 2 safety screws M4 x 14	300	1 pcs.	095741 ACTUATOR S-WQ-LN

- ▶ **Two stainless safety screws per actuator**
- ▶ **Actuators with and without rubber bush**

Notice

Type S actuators must not be used in conjunction with insertion funnels.

L actuators must be used for insertion funnels.

Bent actuator

Suitable for a maximum tensile force of 1,000 N.

Screws made of stainless steel

The safety screws included can be inserted with a normal tool, but cannot be removed again.

Standard actuator S, bent

Without rubber bush, overtravel 5 mm

Dimension drawings

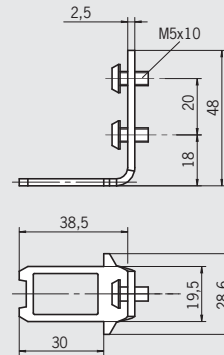

Standard actuator S, bent

With rubber bush, overtravel 5 mm

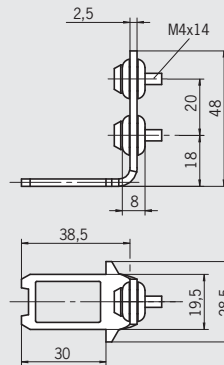

Actuator L, bent, for insertion funnel

With rubber bush, overtravel 5 mm

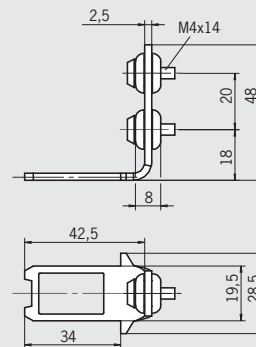

Ordering table

Designation	Version	Min. door radius r [mm]	Packaging unit	Order no.
Actuator S Angled	S-W-SN Without rubber bush, overtravel 5 mm incl. 2 non-removable screws M5 x 10	300	1 pcs.	115073 ACTUATOR S-W-SN-C2115
	S-WT-SN With rubber bush, overtravel 5 mm incl. 2 safety screws M4 x 14	300	1 pcs.	105808 ACTUATOR S-WT-SN-C2115
Actuator L Angled	S-WT-LN With rubber bush, overtravel 5 mm incl. 2 safety screws M4 x 14	300	1 pcs.	105809 ACTUATOR S-WT-LN-C2115

Hinged actuators for safety switches SGA/SGP/STA/STP/STM

- ▶ Actuators made of stainless steel
- ▶ Two stainless safety screws per actuator
- ▶ For doors hinged at top and bottom
- ▶ For doors hinged on the right and left

Hinged actuator

For door radii less than 1,000 mm a hinged actuator should be used. The spring action movement of the actuator prevents damage resulting from the actuator jamming in the actuating head. Depending on the movement of the guard, the actuator must be selected for left/right or top/bottom.

Hinged actuator S-OU-SN
Guard hinged at top/bottom, overtravel 5 mm

Dimension drawings

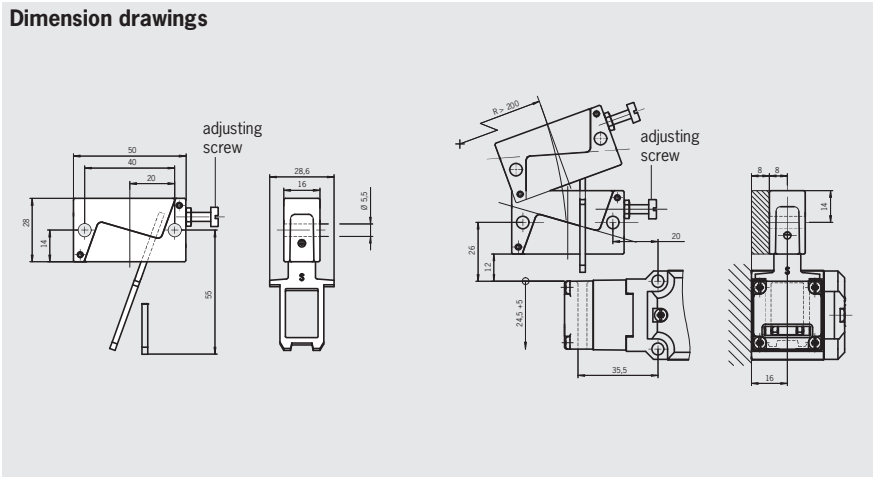

Hinged actuator S-LR-SN
Guard hinged on left/right, overtravel 5 mm

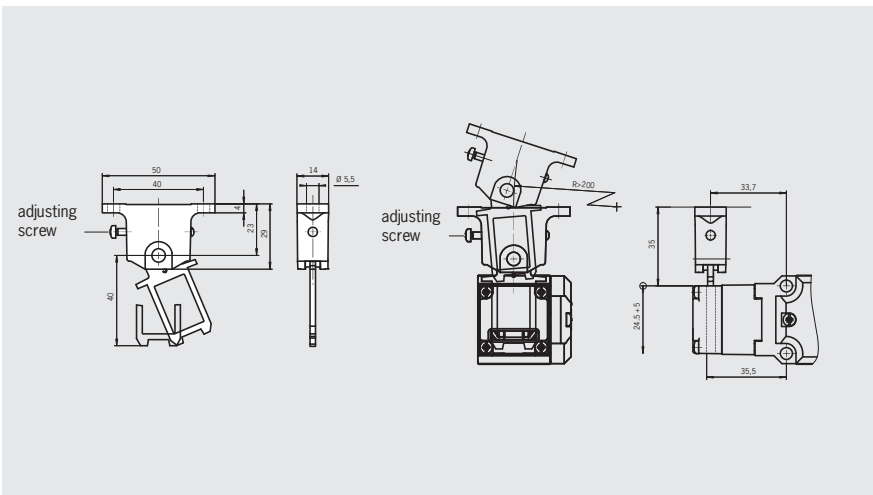

Ordering table

Designation	Version	Min. door radius r [mm]	Packaging unit	Order no.
Hinged actuator	S-OU-SN For doors hinged at top and bottom overtravel 5 mm incl. 2 safety screws M5 x 25	200	1 pcs.	095315 HINGED ACTUATOR-S-OU-SN
	S-LR-SN For doors hinged on the left and right overtravel 5 mm incl. 2 safety screws M5 x 10	200	1 pcs.	096838 HINGED ACTUATOR-S-LR-SN

Hinged actuators for safety switches SGA/SGP/STA/STP/STM

- ▶ Actuators made of stainless steel
- ▶ Two stainless safety screws per actuator
- ▶ For doors hinged at top and bottom
- ▶ For doors hinged on the right and left

Hinged actuator

For door radii less than 1,000 mm a hinged actuator should be used. The spring action movement of the actuator prevents damage resulting from the actuator jamming in the actuating head. Depending on the movement of the guard, the actuator must be selected for left/right or top/bottom.

Hinged actuator S-OU-LN for insertion funnel

Guard hinged at top/bottom, overtravel 5 mm

Dimension drawings

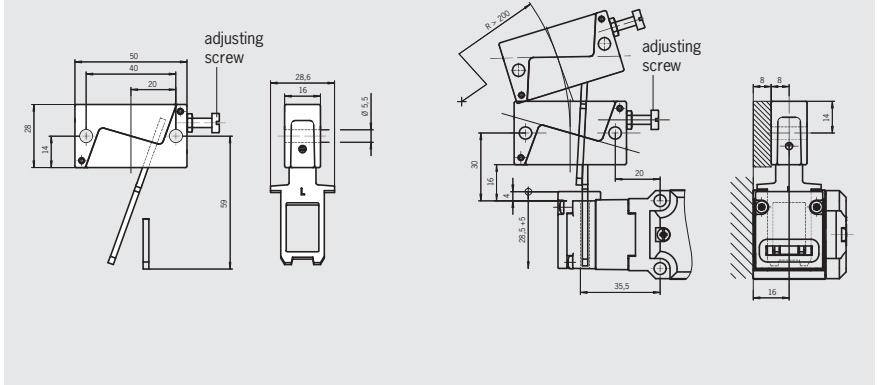

Hinged actuator S-LR-LN for insertion funnel

Guard hinged on left/right, overtravel 5 mm

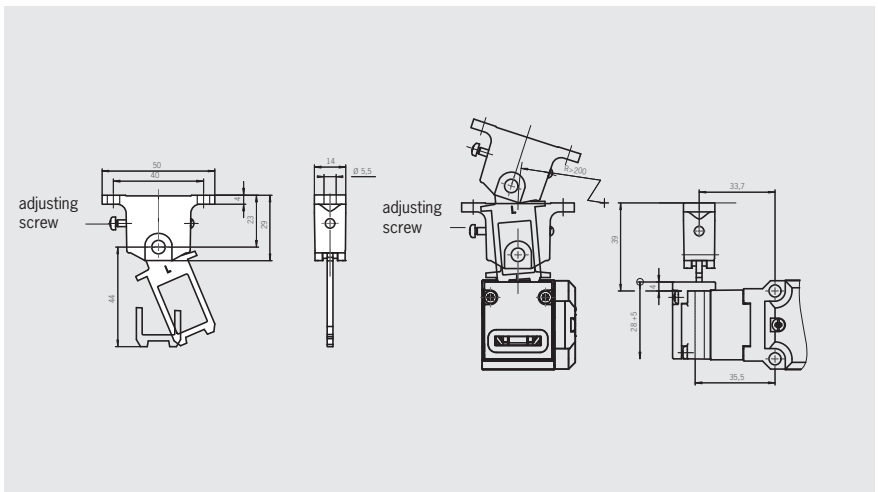

Ordering table

Designation	Version	Min. door radius r [mm]	Packaging unit	Order no.
Hinged actuator	S-OU-LN For doors hinged at top and bottom overtravel 5 mm incl. 2 safety screws M5 x 25	200	1 pcs.	096697 HINGED ACTUATOR-S-OU-LN
	S-LR-LN For doors hinged on the left and right overtravel 5 mm incl. 2 safety screws M5 x 10	200	1 pcs.	096844 HINGED ACTUATOR-S-LR-LN

Insertion funnels/adapters

- ▶ Insertion funnel
- ▶ Adapter NP-K

Insertion funnel

If an insertion funnel is used, even in exactly positioned actuators are inserted reliably in the actuating head due to the large opening funnel, thus protecting the safety switch against mechanical influences.

- ▶ Cannot be used in conjunction with TP safety switches with increased overtravel from the top
- ▶ The insertion funnel for TP can only be used in conjunction with an actuator with long overtravel
- ▶ The insertion funnel for STP can only be used in conjunction with an actuator for insertion funnel

Adapter NP-K

The adapter NP-K is used for top entry overtravel applications for the NP series.

- ▶ The adapter **cannot** be used for safety switches of the GP/TP series
- ▶ 4 screws 3 x 38 (not safety screws) are included

Insertion funnel for safety switches NM..VZ

Dimension drawings

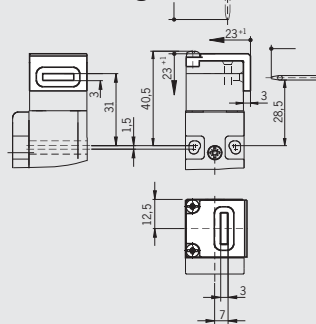

Minimum door radii with insertion funnel

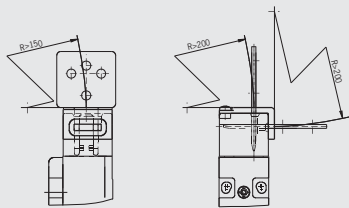

Insertion funnel for safety switches NP..A/GP/TP..A

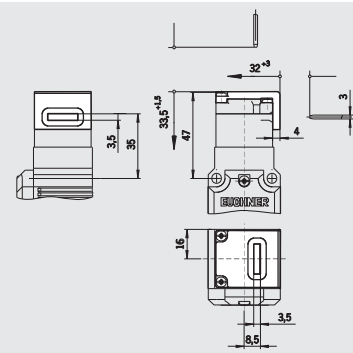

Minimum door radii with insertion funnel

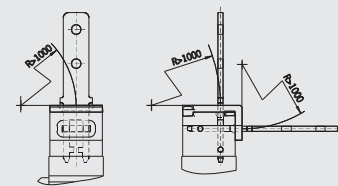

Insertion funnel for safety switches SGP/STA/STP/STM

Dimension drawings

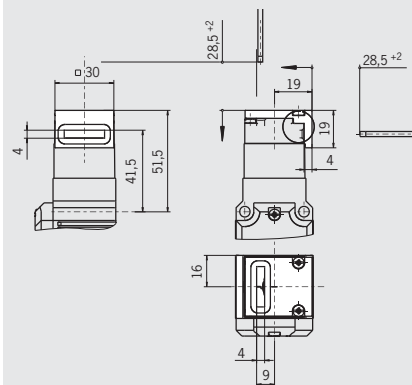

Minimum door radius with insertion funnel
R > 300 mm

Adapter NP-K For safety switches NP

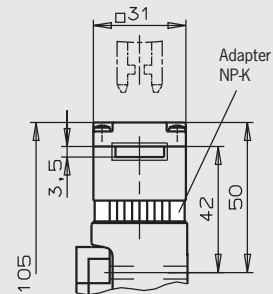

Ordering table

Designation	Version	Use	Order no.
Insertion funnel	incl. 2 fixing screws	For safety switches NM..VZ	083565 Insertion funnel M
		For safety switches NP..A/GP/TP..A without adapter	086237 Insertion funnel NP/GP/TP
		For safety switches SGP/STA/STP/STM	093157 Insertion funnel STP/STM
Adapter NP-K	incl. 4 fixing screws	For safety switches NP	074578 Adapter NP-K

Mounting plates EMP for safety switches SGA, SGP, TP...A, STA and STP

- For vertical and horizontal mounting of safety switches SGA, SGP, TP...A, STA and STP

The mounting plates are used for fastening safety switches TP...A, STA, STP and actuators to guards. The safety switches can be attached vertically or horizontally.

Note

- Mounting plate material: galvanized St37.

Installation example, safety switch vertical

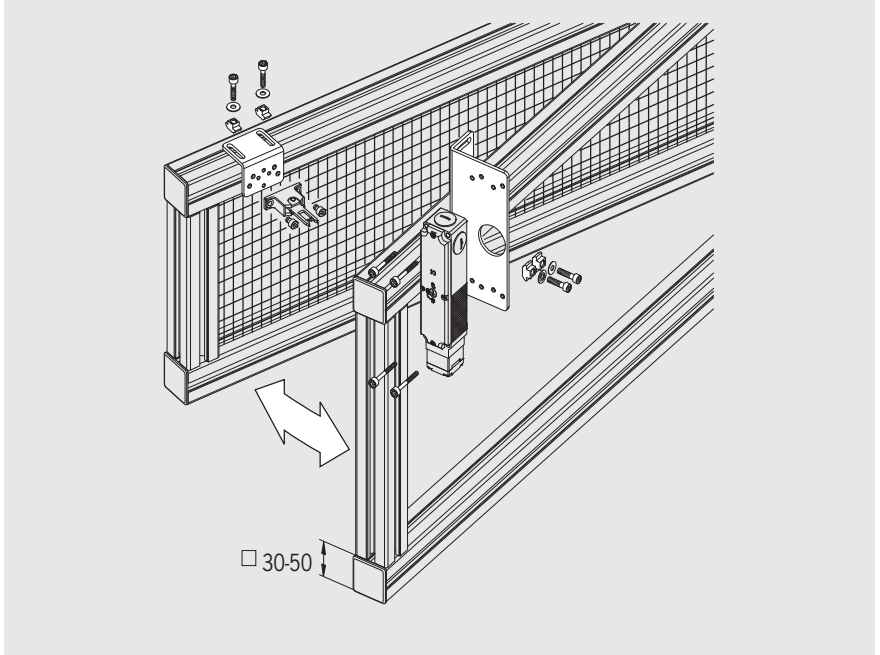

Ordering table

Switch	Mounting plate Switch	Installation method Switch	Mounting plate Actuator	Actuator		Minimum distance hinged actuator to switch	
				ST...	TP...A	ST...	TP...A
SGA... SGP... TP...A... STA... STP...	093456 EMP-SB 	A Vertical	093457 EMP-B1 	070038 074577 Page 93	070038 074577 Page 93	> 300 mm	> 1,000 mm
	126026 AM-P 		093457 EMP-B1 	095315 096697 Page 98/99	059440 074573 Page 94/95	> 200 mm	> 100 mm
	093458 EMP-B2 	B Horizontal	096838 096844 Page 98/99	070050 074572 Page 94/95	> 200 mm	> 90 mm	

For technical data, see page 121

Mounting bracket for safety switches NM and NP...AS

- ▶ For vertical and horizontal mounting of safety switches NM and NP...AS

The mounting bracket is used for fastening safety switches NM and NP...AS to guards. The safety switches can be attached horizontally or vertically.

Notes

- ▶ Mounting plate material: galvanized St37.

Mounting bracket

For safety switches NM and NP...AS

Dimension drawings

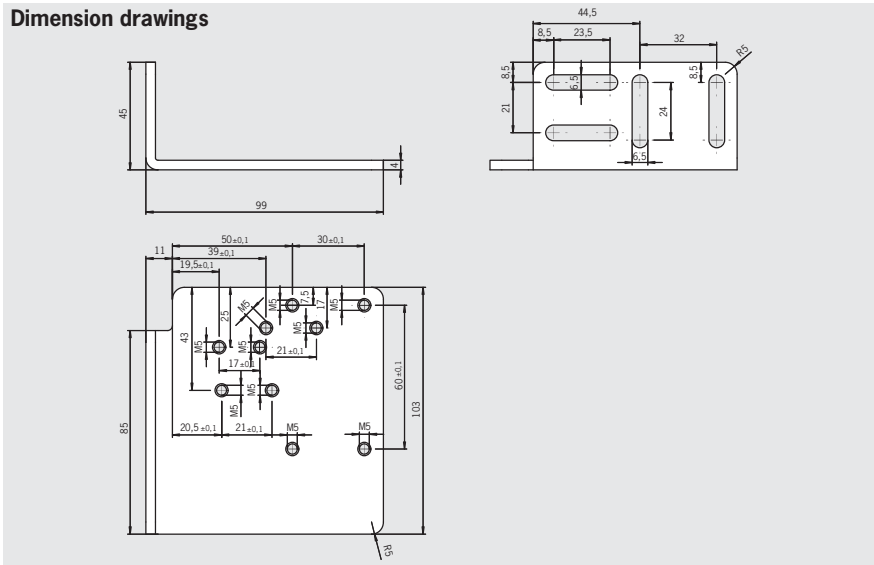

Ordering table

Designation	Use	Order no.
Mounting bracket NM, NP	For safety switches NM and NP...AS horizontal and vertical mounting	085753 EMP-SC

Plug connector M12

- ▶ Plug connector M12 with cable
- ▶ 90° angled optional

Cable

Cable sleeve PUR, color black, halogen free, flame retardant.

Straight plug connector with cable

M12 plug, 4-pin

Dimension drawings

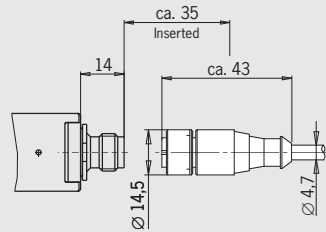

Wiring diagram
(view of connection side)

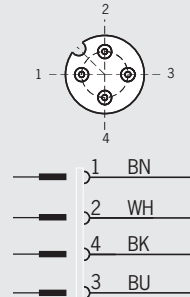

Angled plug connector with cable

M12 plug, 4-pin

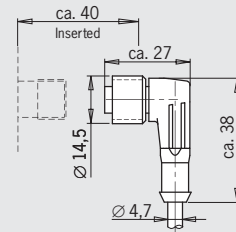

Wiring diagram
(view of connection side)

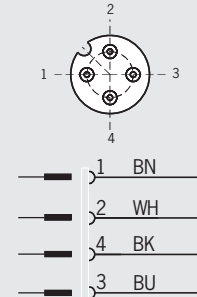

Straight plug connector with cable

M12 plug, 8-pin, flying lead

Dimension drawings

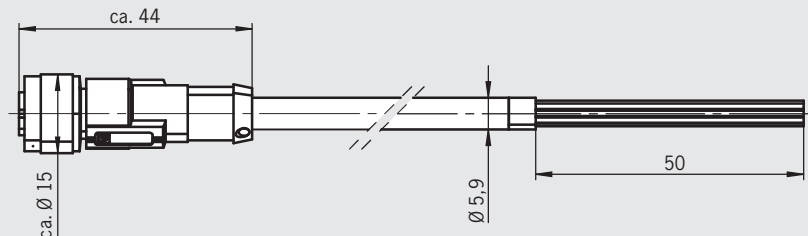

Wiring diagram
(view of connection side)

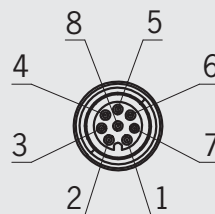

Pin	Wire color
1	WH
2	BN
3	GN
4	YE
5	GY
6	PK
7	BU
8	RD

Ordering table

Designation	Number of pins	Version	Cable length			
			5 m	10 m	20 m	30 m
Plug connector M12	4 4 x 0.34 mm ²	Female connector M12 for male plug SM4	035613 C-M12F04-04X034PU05,0-GA	-	-	-
		Female connector M12, angled, for male plug SM4	035618 C-M12F04-04X034PU05,0-GA	-	-	-
	8 8 x 0.25 mm ²	Female connector M12 for male plug SM8	115112 C-M12F08-08X025PU05,0-MA	115113 C-M12F08-08X025PU10,0-MA	115114 C-M12F08-08X025PU20,0-MA	115257 C-M12F08-08X025PU30,0-MA

Plug connectors SR6 and SR11

- ▶ Plugs and sockets
- ▶ Crimp contacts
- ▶ 90° angled optional
- ▶ Cable optional
- ▶ Coding shells

Angled plug connector

On plug connectors without cables the direction of the cable exit can be adjusted.

Male socket

For fitting in safety switches.

Coding shells

Only matching connectors can be mated when coding shells are used.

Cable (optional)

Cable sleeve PUR, color gray, conductor cross-section 1.0 mm² (individual lines numbered).

Female connector SR6 EF 6-pin + PE

Dimension drawings

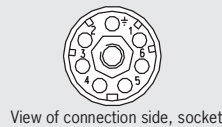
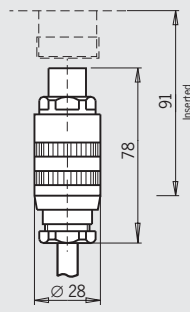

Female connector SR6 WF, angled, 6-pin + PE

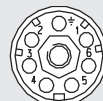
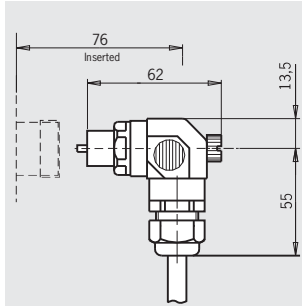

View of connection side, socket

Male socket SR6 AM 6-pin + PE

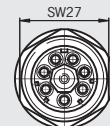
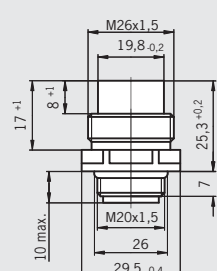

View of connection side, plug

Female connector SR11 EF 11-pin + PE

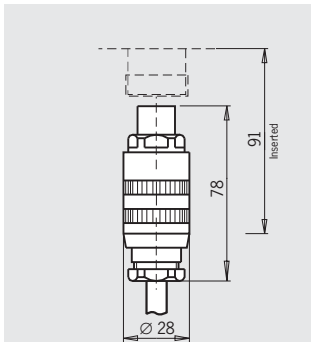

View of connection side, socket

Female connector SR11 WF, angled, 11-pin + PE

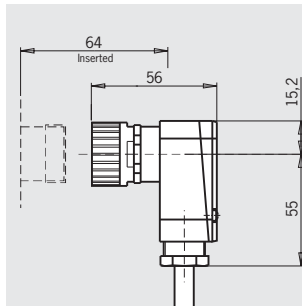

View of connection side, socket

Male socket SR11 AM 11-pin + PE

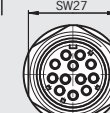
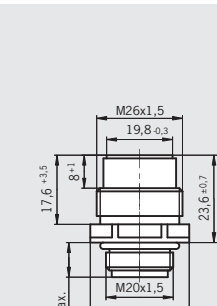

View of connection side, plug

Connector assignment for plug with cable

SR6		SR11	
Pin	Wire	Pin	Wire
1	1	1	1
2	2	2	2
3	3	3	3
4	4	4	4
5	5	5	5
6	6	6	6
⊕	7	7	7
		8	8
		9	9
		10	10
		11	11
		⊕	12

Ordering table

Designation	Version	Cable					
		without	5 m	10 m	15 m	20 m	25 m
SR6 ¹⁾ 6-pin + PE	EF Female connector	013176 SR6EF	077632 CM26F07-07X1,0PU05,0- MA-077632	077633 CM26F07-07X1,0PU10,0- MA-077633	077634 CM26F07-07X1,0PU15,0- MA-077634	098128 CM26F07-07X1,0PU20,0- MA-098128	-
	WF Female connector, angled	024999 SR6WFG11R	077638 C-R22F07-07X1,0PU05,0- MA-077638	077639 C-R22F07-07X1,0PU10,0- MA-077639	077640 C-R22F07-07X1,0PU15,0- MA-077640	-	-
	CI Coding shells	013178 SR6K	-	-	-	-	-
	AM Male socket, connection M20x1.5	087180 SR6AM2-M20	-	-	-	-	-
SR11 ¹⁾ 11-pin + PE	EF Female connector	070859 SR11EF	077629 CM26F12-12X1,00PU05,0- MA-077629	077630 CM26F12-12X1,00PU10,0- MA-077630	077631 CM26F12-12X1,00PU15,0- MA-077631	096632 CM26F12-12X1,00PU20,0- MA-096632	094749 CM26F12-12X1,00PU25,0- MA-094749
	WF Female connector, angled	054773 SR11WF	077635 C-M26F12-12X1,0PU05,0- MA-077635	077636 C-M26F12-12X1,0PU10,0- MA-077636	077637 C-M26F12-12X1,0PU15,0- MA-077637	-	-
	AM Male socket, connection M20x1.5	091296 SR11AM2-M20	-	-	-	-	-
SR6 and SR11	Socket crimp contacts Conductor cross-section 0.5 - 1.5 mm ²	071260 SRF	-	-	-	-	-
	Pin crimp contacts Conductor cross-section 0.5 - 1.5 mm ²	071261 SRM	-	-	-	-	-

¹⁾ Crimp contacts are included. For information on crimp contacts, see page 119.

Plug connector M23 (RC18) and M23 (RC18) with option C1825

- ▶ Straight and angled plug connectors
- ▶ With and without plug connector

Crimp contacts

With 19 crimp pins for conductor cross-section 0.75 - 1.00 mm².

Option C1825

With 16 crimp pins for conductor cross-section 0.25 - 0.5 mm² and 3 pins for conductor cross-section 0.75 - 1.0 mm² for control of the guard locking solenoid. This plug is easier to connect.

Important: Only for switch with option C1826.

Angled plug connector (optional)

On plug connectors with cables the direction of the cable exit can be chosen on left/right. On plug connectors without cables the direction can be adjusted in 45° steps.

Coupling socket

Coupling socket straight, 19-pin, with screen bonding clamp. Suitable for extension of female connector RC18EF-C1825 and RC18WF-C1825.

Halogen-free cable

Cable sleeve PUR, color black, halogen-free, silicone-free. Reduction of toxic gases and smoke in case of fire.

Conductor cross-section 0.5 mm² or 1.0 mm².

Female connector M23 (RC18) / M23 (RC18)..C1825

18-pin + PE (for cable diameter 10 ... 14 mm)

Dimension drawings

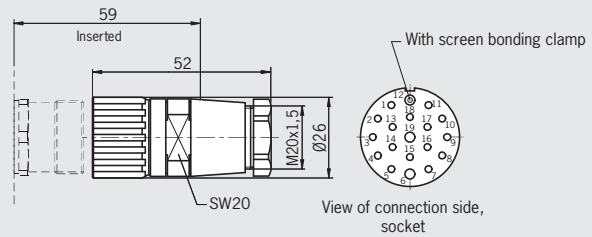

Female connector M23 (RC18) / M23 (RC18)..C1825

Angled 18-pin + PE (for cable diameter 10 ... 14 mm)

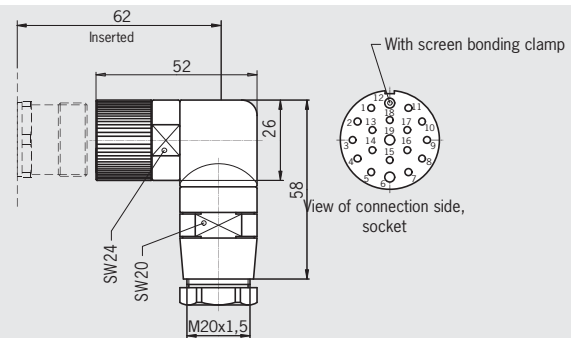

Coupling socket M23 (RC18) / M23 (RC18)..C1825

18-pin + PE (for cable diameter 10 ... 14 mm)

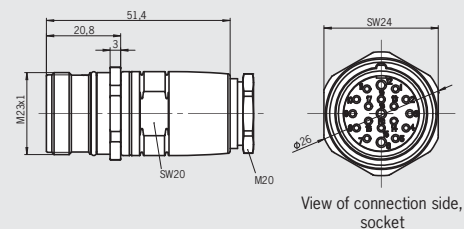

Ordering table

Designation	Version	Without cable
M23 (RC18) ²⁾ 18-pin + PE	EF Female connector	074616 RC18EF
	WF Female connector, angled ¹⁾	074617 RC18WF
	Replacement pin crimp contacts Conductor cross-section 19 x 0.75 - 1 mm ²	094309 Pin crimp contact RCF
	EF-C1825 Female connector	077025 RC18EF-C1825
	WF-C1825 Female connector, angled ¹⁾	077026 RC18WF-C1825
	Replacement crimp contacts Conductor cross-section 16 x 0.25 - 0.5 mm ² 3 x 0.75 - 1 mm ²	094310 Pin crimp contact RCF-C1825
	EM-C1825 Coupling socket	129500 RC18EM-C1815
	Replacement crimp contacts Conductor cross-section 16 x 0.25 - 0.5 mm ² 3 x 0.75 - 1 mm ²	155811 Pin crimp contact RCM-C1825

For information on crimp contacts, see page 119.

1) Plug connector RC18 on the switches STP/STA not aligned.

2) Crimp contacts are included.

Female connector M23 (RC18) / M23 (RC18)..C1825 with cable

18-pin + PE / 19-pin PUR

Dimension drawings

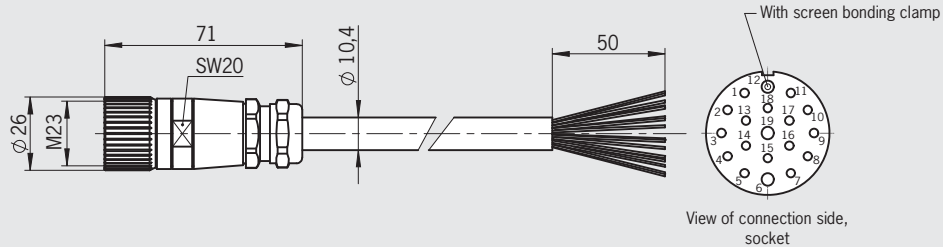

Female connector M23 (RC18) / M23 (RC18)..C1825, angled, with cable 18-pin + PE

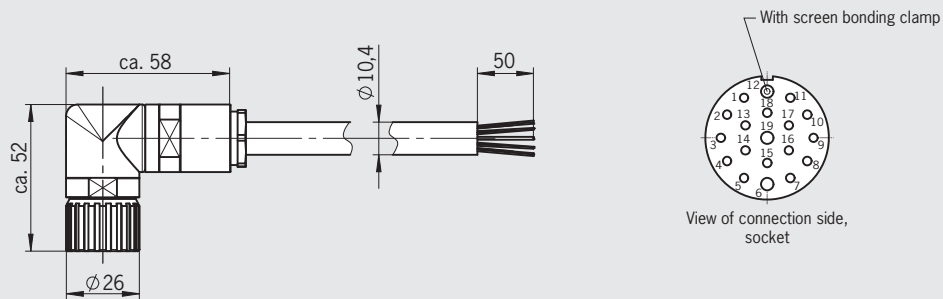

Connector assignment plug M23 (RC18) with cable and option C1825

Pin	Wire color	Cond. cross-section [mm]
1	VT	0.5
2	RD	0.5
3	GY	0.5
4	RD/BU	0.5
5	GN	0.5
6	BU	1.0
7	GY/PK	0.5
8	GN/WH	0.5
9	YE/WH	0.5
10	GY/WH	0.5
11	BK	0.5
12	GN/YE	1.0
13	PK	0.5
14	BN/GY	0.5
15	BN/YE	0.5
16	BN/GN	0.5
17	WH	0.5
18	YE	0.5
19	BN	1.0

Ordering table

De-scrip.	Version	Cable									
		1.5 m	3 m	6 m	8 m	10 m	15 m	20 m	25 m	30 m	40 m
RC18 18-pin + PE with cable	Straight female connector	092761 C-M23F19-19XDIF-PU01,5-MA-092761	092816 C-M23F19-19XDIF-PU03,0-MA-092816	077014 C-M23F19-19XDIF-PU06,0-MA-077014	077015 C-M23F19-19XDIF-PU08,0-MA-077015	092898 C-M23F19-19XDIF-PU010,0-MA-092898	077016 C-M23F19-19XDIF-PU15,0-MA-077016	092726 C-M23F19-19XDIF-PU20,0-MA-092726	092727 C-M23F19-19XDIF-PU25,0-MA-092727	095993 C-M23F19-19XDIF-PU30,0-MA-095993	102490 C-M23F19-19XDIF-PU40,0-MA-102490
	Female connector, angled, cable exit left	092906 C-M23F19-19XDIF-PU01,5-MA-092906	092908 C-M23F19-19XDIF-PU03,0-MA-092908	077018 C-M23F19-19XDIF-PU06,0-MA-077018	077019 C-M23F19-19XDIF-PU08,0-MA-077019	092901 C-M23F19-19XDIF-PU010,0-MA-092901	077020 C-M23F19-19XDIF-PU15,0-MA-077020	092910 C-M23F19-19XDIF-PU20,0-MA-092910	092912 C-M23F19-19XDIF-PU25,0-MA-092912	-	-
	Female connector, angled, cable exit right	092907 C-M23F19-19XDIF-PU01,5-MA-092907	092909 C-M23F19-19XDIF-PU03,0-MA-092909	085194 C-M23F19-19XDIF-PU06,0-MA-085194	085195 C-M23F19-19XDIF-PU08,0-MA-085195	092902 C-M23F19-19XDIF-PU010,0-MA-092902	085196 C-M23F19-19XDIF-PU15,0-MA-085196	092911 C-M23F19-19XDIF-PU20,0-MA-092911	092913 C-M23F19-19XDIF-PU25,0-MA-092913	-	-

Plug connectors MR8/MR9/MR10/MR12 with cable

Female connector with cable
8-, 9-, 10-, 12-pin

Dimension drawings

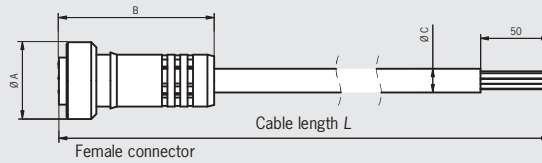

Dimension	8-pin	9-pin	10-pin	12-pin
A	∅ 29	∅ 32	∅ 32	∅ 32
B	59	64	64	64
C	∅ 8.9	∅ 9.7	∅ 9.8	∅ 10.4

Pin assignment (conductor cross-section 0.82 mm² / 18 AWG)

8-pin			9-pin			10-pin			12-pin		
Pin	Wire color	View of connection side, socket	Pin	Wire color	View of connection side, socket	Pin	Wire color	View of connection side, socket	Pin	Wire color	View of connection side, socket
1	OG		1	OG		1	OG		1	OG	
2	BU		2	BU		2	BU		2	BU	
3	WH/BK		3	RD/BK		3	WH/BK		3	WH/BK	
4	BK		4	GN/BK		4	RD/BK		4	RD/BK	
5	WH		5	WH		5	GN/BK		5	GN/BK	
6	RD		6	RD		6	OG/BK		6	OG/BK	
7	GN/YE		7	GN/YE		7	RD		7	BU/BK	
8	RD/BK		8	WH/BK		8	GN/YE		8	BK/WH	
		9	BK	9		BK	9		GN/YE		
				10	WH	10	RD				
						11	WH				
						12	BK				

Ordering table

Version	Connection Material	Cable length L [mm]									
		910	1,800	3,600	6,000	9,100	12,100	15,200	18,200	24300	
Female connector with cable	MR8	PVC	-	100938	-	100940	100941	100942	103152	103153	-
		PUR	-	102506	100945	100946	102507	102508	102509	103149	103150
	MR9	PVC	100947	102502	100948	102503	102504	103154	-	103156	-
		PUR	-	102510	102511	102512	102513	102514	102515	103151	-
	MR10	PVC	-	100949	100950	100951	100952	102505	100953	103157	-
		PUR	-	102516	102517	102518	100956	102519	102520	102521	-
	MR12	PVC	-	-	100960	100961	100962	103158	103159	103160	-
		PUR	-	-	100967	102522	102523	102524	102525	102526	-

Cable glands

- ▶ M12 x 1.5
- ▶ M16 x 1.5
- ▶ M20 x 1.5

Cable glands

Suitable for various cable diameters. Versions available in plastic and metal.

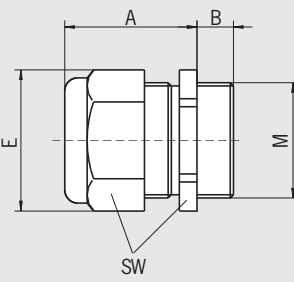

Item	Thread	Cable Ø [mm]	A [mm]	B [mm]	E [mm]	SW [mm]
EKV.12/04	M12 x 1.5	4 - 6.5	20	5	15.5	14
EKV.16/04	M16 x 1.5	4 - 6.5	20	6	20	18
EKP.16/05	M16 x 1.5	5 - 10	28	8	22	20
EKV.16/06	M16 x 1.5	6.5 - 9.5	20	6	20	18
EKV.20/06	M20 x 1.5	6.5 - 9.5	20	6	24.4	22
EKP.20/06	M20 x 1.5	6 - 12	26	11	27	24
EKV.20/09	M20 x 1.5	9 - 13	20	6	24.4	22
EKV.12/06	NPT ½"	6 - 12	22	13	27	24
EKVPO.12/06	NPT ½"	6 - 12	26	13	27	24

Ordering table

Thread	Version	Material	
		Metal	Plastic
M12 x 1.5	Cable diameter 4 - 6.5 mm	086327 EKVM12/04	-
	Cable diameter 4 - 6.5 mm	086328 EKVM16/04	-
M16 x 1.5	Cable diameter 5 - 10 mm	-	084572 EKPM16/05
	Cable diameter 6.5 - 9.5 mm	086330 EKVM16/06	-
M20 x 1.5	Cable diameter 6 - 12 mm	-	077679 EKPM20/06
	Cable diameter 6.5 - 9.5 mm	077683 EKVM20/06	-
	Cable diameter 9 - 13 mm	077684 EKVM20/09	-
NPT ½"	Cable diameter 6 - 12 mm	077691 EKVN12/06	077692 EKPON12/06

LED indicators for safety switches GP/ TP and STP

- ▶ LED set
- ▶ Built-in LED

LED set

Consisting of cover with lamp caps, LED module with rectifier and two LEDs (green/red). For retrofitting safety switches TP and STP with an LED indicator.

Operating voltage AC/DC 24 V +10%, -15%.

Built-in LED

The built-in LED is suitable for direct installation in one of the M20 x 1.5 threads of the three cable entries of the safety switches GP/TP/STP.

The built-in LED indicates to the user whether the switch is locked or whether the safety door is open/closed.

The switching element can be wired individually. Operating voltage DC 24 V +10%, -15%.

LED set

For safety switches TP/STP

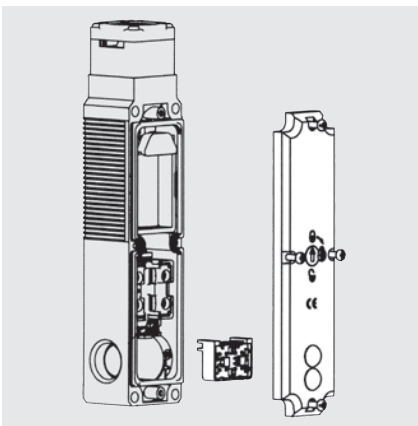

Built-in LED

For safety switches GP/TP/STP/STA

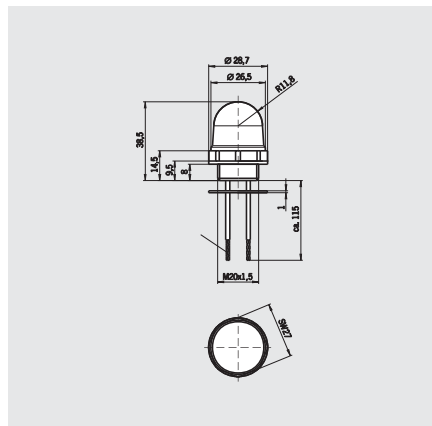

Ordering table

Designation	Version	Use	Packaging unit	Order no.
LED set	Incl. cover with lamp caps and LED module with rectifier and 2 LEDs (red/green)	For safety switches TP	1 pcs.	093752 LED set TP
		For safety switches STP	1 pcs.	098035 LED set STP
Built-in LED (IP 65)	Color red for cable entry M20 x 1.5, with seal Light radiation to side	For safety switches GP/TP/STA/STP	1 pcs.	087423 LED M20x1.5
	Color red for cable entry M20 x 1.5, with seal light radiation to front	For safety switches GP/TP/STA/STP	1 pcs.	095510 LED-F M20x1.5

Miscellaneous accessories

- ▶ Lockout bar
- ▶ Latch spring for increased retention force
- ▶ Lock for mechanical release

Lockout bar

With the safety door open, it can be slid into the actuating head on a switch type 2 (NP/GP/TP/STA/STP/STM) instead of an actuator. Removal can be prevented using a commercially available padlock (max. 3 ea.). For the protection of people in areas with a possible hazard.

Lockout bar

For safety switches NP/GP/TP

Dimension drawings

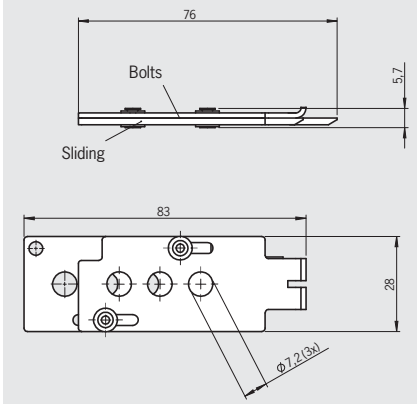

Lockout bar

For safety switches SGA/SGP/STA/STP/STM

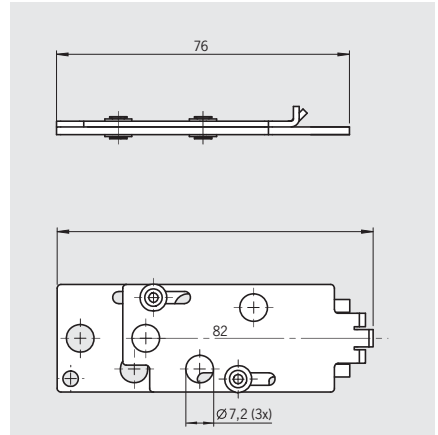

Latch spring

Offers an increased retention force of approx. 30 N for safety switches NP and GP or TP in unlocked condition.

May only be used in conjunction with the straight actuator with rubber bush (order no. 070 046).

Latch spring for increased retention force

For safety switches NP/GP/TP

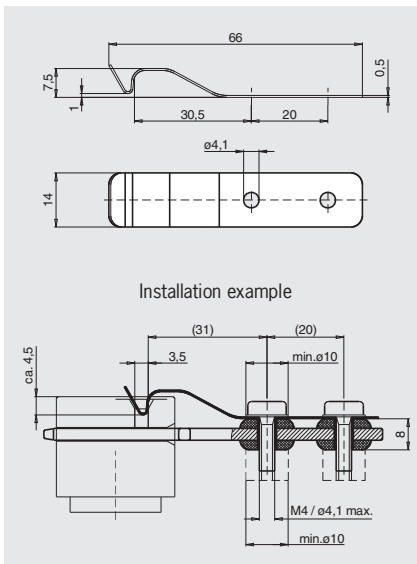

Lock

For safety switches TP/STP/STA

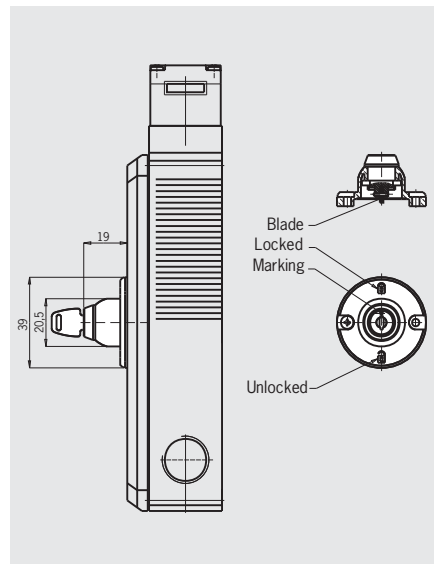

Lock

The lock is used in combination with safety switch TP/STP/STA. The mechanical key release enables authorized personnel to actuate the mechanical release using the related key. The unlocking mechanism holds the solenoid in the "unlocked" position.

Two screws are used to fix the lock to the cover of the safety switch TP/STP/STA (above the mechanical release).

- ▶ Order safety switch TP/STP/STA separately
- ▶ 2 keys are included
- ▶ Every safety switch of the series TP/STP/STA can be upgraded to include a lock

Ordering table

Designation	Version	Use	Order no.
Lockout bar	3 holes	For safety switches NP/GP/TP	096105 Lockout bar TP
		For safety switches SGA/SGP/STA/STP/STM	105701 Lockout bar STP
Latch spring		For safety switches NP/GP/TP	076501 Latch spring NP/TP
Lock	Unique locking (unique key needed to open)	For safety switches TP/STP	084177 Lock TP
	Identical locking (identical locks)	For safety switches TP/STP	086236 Lock TP
	Identical locking (identical locks) key can be removed only in locked position	For safety switches TP/STP	109212 Identical lock TP C2293
	Identical locking (identical locks) key can only be removed in locked position	For safety switches TP/STP	121917 Identical lock TP
	Identical locking (identical locks)	For safety switch STA	105350 Lock STA
	Replacement key (2 x) for identical locking	For safety switches TP/STP/STA/SGP-TW	099434 Replacement key for identical TP
	Replacement key (2 x) for unique locking	For safety switches TP/STP/TX	077206 Replacement key TP unique locking

Miscellaneous accessories

- ▶ Emergency unlocking for safety switches TP/STP
- ▶ Emergency unlocking for safety switches STA
- ▶ Mechanical release with automatic reset for safety switches TP/STP
- ▶ Handle for escape release
- ▶ Triangular key for safety switch TK

Emergency unlocking

Is used for the manual release of the guard locking without tools. The emergency unlocking mechanism must be returned to the locked state manually. Sealing can be fitted to protect against tampering.

Attention: Prior to mounting, the locking screw for the mechanical release must be removed.

Emergency unlocking For safety switches TP/STP

Dimension drawings

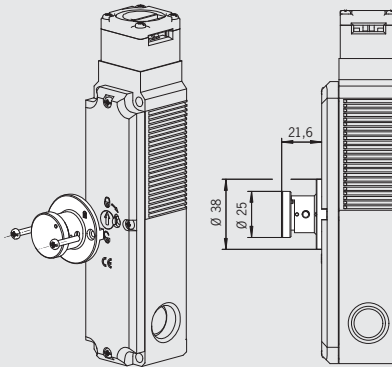

Emergency unlocking For safety switch STA

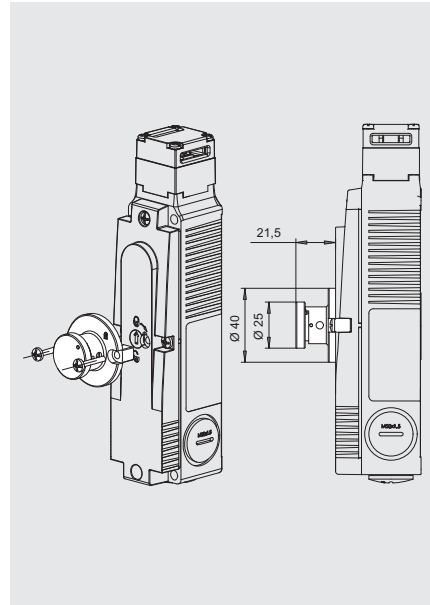

Release

Is used for the manual release of the guard locking. The integrated spring automatically resets the release to the locked state.

Attention: Prior to mounting, the locking screw for the mechanical release must be removed.

Release with automatic reset For safety switches TP/STP

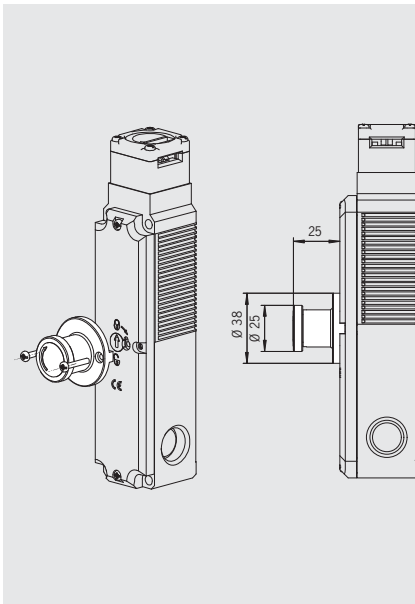

Handle for escape release For safety switches TP/STP/STA

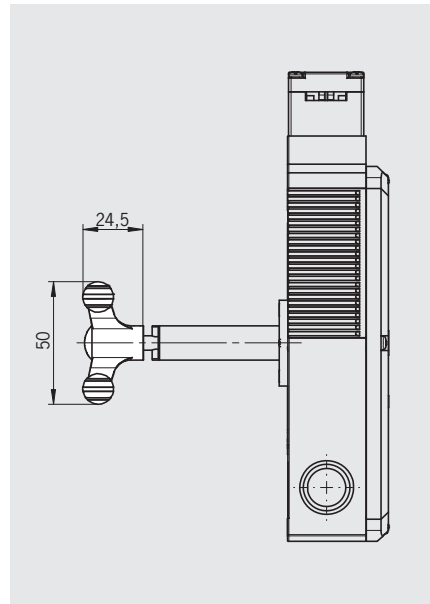

Handle for escape release

Can be mounted on all escape release actuator shafts C1993 for safety switches TP, STP and STA for easier use.

Ordering table

Designation	Version	Use	Order no.
Emergency unlocking	incl. 2 screws M3 x 17	For safety switches TP/STP	099877 Emergency unlocking TP/STP
	incl. 2 screws M3.5 x 19	For safety switch STA	099876 Emergency unlocking STA
Release with automatic reset	incl. 2 screws M3 x 17	For safety switches TP/STP	103110 Release with automatic reset TP/STP
Handle for escape release		For safety switches TP/STP/STA with escape releases with long actuator shaft (74.7 mm)	105329 Escape release handle
Triangular key	DIN 22417 M5 100 mm	For safety switch TK	103057 Triangular key

Miscellaneous accessories

- ▶ **Wire front release (bowden) (no automatic return)**
- ▶ **Handle for wire front release (bowden)**
- ▶ **Safety screws**
- ▶ **Replacement screws**

Wire front release (bowden)

Flexible routing of the pull wire permits release of the guard locking in inaccessible installation situations.

- ▶ Usage as emergency unlocking if the safety switch is mounted in an inaccessible position
- ▶ Usage as escape release for unlocking the guard locking from the danger zone
- ▶ Can be retrofitted to all series TP/STP safety switches

Safety screws

To prevent unscrewing of actuators and actuating heads. The screws can be tightened using a normal tool, but cannot be removed again.

Replacement screws

For mounting actuating heads (not safety screws).

Wire front release (bowden)
For safety switches TP/STP

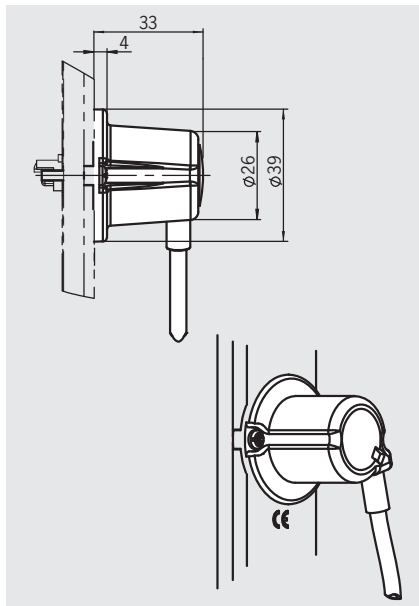

Handle for wire front release (bowden)
For safety switches TP/STP

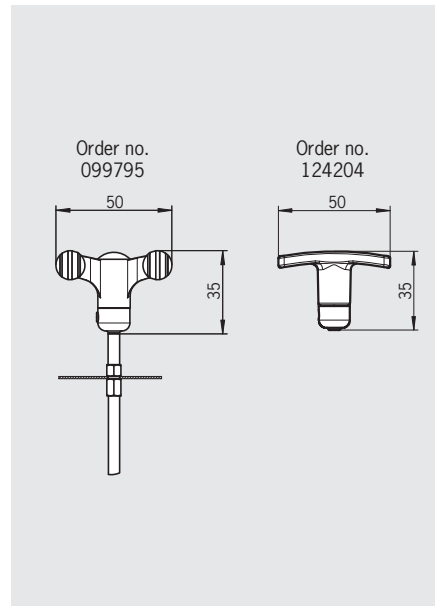

Ordering table

Designation	Version	Detent mechanism	Use	Order no.
Wire front release (bowden) incl. pull wire and sheath	Length 6 m (2 m sheathed)	No automatic return	For safety switches CTP/TP/STP/STA	096230 AE-BA1-02,0-096230
		automatic return	For safety switches CTP/TP/STP/STA	097747 AE-BA1-02,0-F-097747
	Length 6 m (3 m sheathed)	No automatic return	For safety switches CTP/TP/STP/STA	098313 AE-BA1-03,0-098313
		automatic return	For safety switches CTP/TP/STP/STA	111233 AE-BA1-03,0-F-111233
	Length 6 m (4 m sheathed)	No automatic return	For safety switches CTP/TP/STP/STA	098314 AE-BA1-04,0-098314
Bowden cable Without sheath	Length 6 m	automatic return	For safety switches CTP/TP/STP/STA	124770 AE-BA1-06,0-F-124770
		No automatic return	For safety switches CTP/TP/STP/STA	125582 AE-BA1-06,0-125582
Sheath For bowden cable	Length 50 m	-	For safety switches CTP/TP/STP/STA	123032 AY-CAH-50,0-123032
Handle for wire front release (bowden)			For safety switches TP/STP	099795 Handle for wire front release (bowden)
				124204 AY-HDL-124204
Safety screws Packaging unit: 100 pcs.	M5 x 25		For hinged actuator for doors hinged on the top and bottom of series NM..VZ, NP..., GP... and TP...	073457 M5x25/V100
	M5 x 10 Material: stainless steel		For straight/bent actuators/hinged actuators for doors hinged on the right and left of series NM..VZ, NP..., GP... and TP...	073455 M5x10/V100
	M4 x 14		For all actuators of series NM..VZ	074063 M4x14/V100
	M4 x 14 Material: stainless steel		For straight/bent actuators with bush of series NP..., GP... and TP...	086232 M4x14/V100
Replacement screws Packaging unit: 100 pcs. (not safety screws)	PL3x26		Cap screws for series NM..AL, NM..AG, NM..AK, NM..AV and NM..VZ	085576 PL3x26/V100
	PL3x30		Cap screws for series NP...A, GP... and TP...A	075532 PL3x30/V100
	PL3x30 Material: stainless steel		Cap screws for series NP...A, GP... and TP...A	082237 PL3x30/V100
	PL3x38		Cap screws for series NP...K and TP...K	076755 PL3x38/V100

Bolts for guards for safety switches NM

- ▶ For doors hinged on the right or left



Features

- ▶ Easily fitted to standard aluminum profiles and machine covers by screw connection
- ▶ Distinctive yellow color for easy recognition
- ▶ Symmetrical design for doors hinged on the right or left
- ▶ No additional door handle necessary
- ▶ Bolt with detent mechanism in opened position
- ▶ Through hole on the bolt permits attachment of padlocks

Notes

- ▶ Actuator and switch bracket included in the bolt's scope of delivery
- ▶ Order safety switch separately

Bolt for safety switches NM..VZ

Dimension drawings

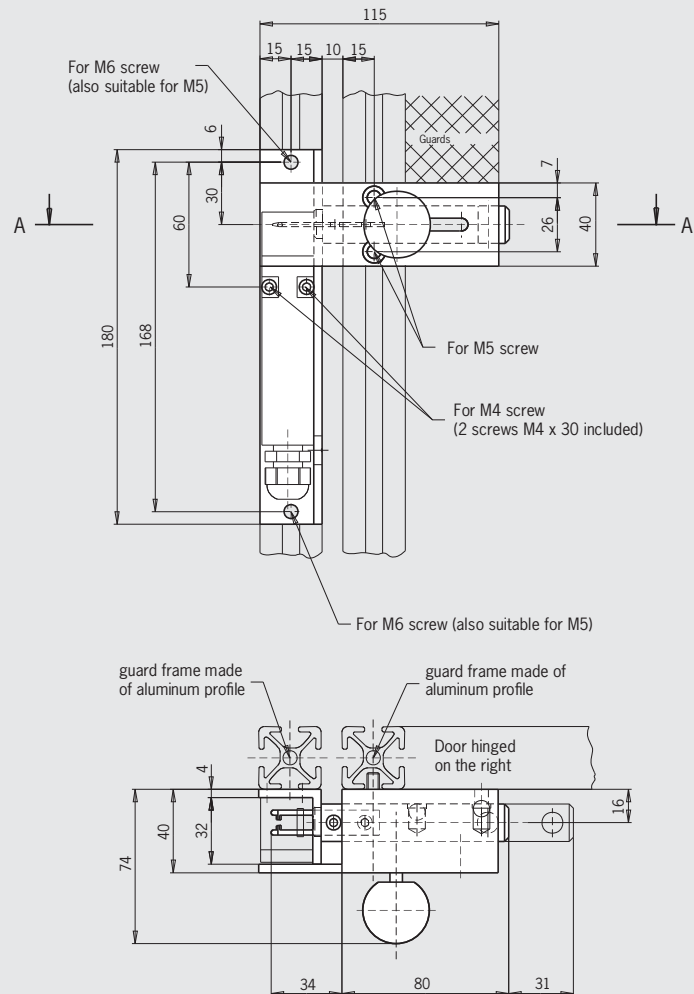

Section AA

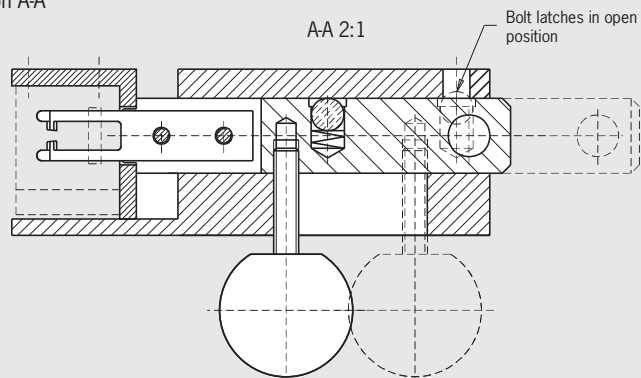

Ordering table

Designation	Detent mechanism	Version	Order no.
Bolt NM	without	for doors hinged on the right or left actuator and switch bracket included	077233 Bolt NM
Switch bracket NM		Separate	077245 Switch bracket NM

Bolts for guards for safety switches NP, GP and TP

- ▶ For doors hinged on the right or left

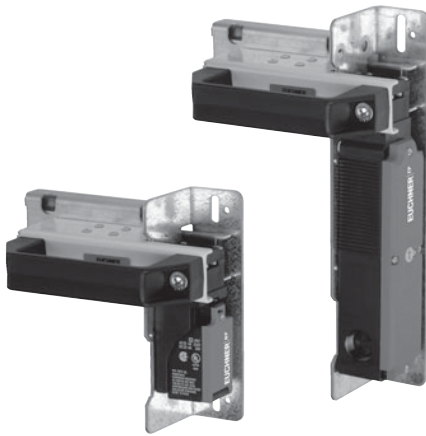

Features

- ▶ Easily fitted to standard aluminum profiles and machine covers by screw connection
- ▶ Distinctive yellow color for easy recognition
- ▶ Symmetrical design for doors hinged on the right or left
- ▶ No additional door handle necessary
- ▶ Automatic detent mechanism when bolt is moved to the end position (only available on **bolt 1 NP/TP** version)
- ▶ Detent mechanism prevents unintentional opening of the hinged door
- ▶ Slot on the bolt permits attachment of padlocks
- ▶ Bolts for safety switches **NP...AS** and **TP...A** are identical

Notes

- ▶ Switch bracket **NP** is only suitable for series **NP...AS**
- ▶ Switch bracket **TP** is only suitable for the series **TP...A** and **GP**
- ▶ Actuator included
- ▶ Order safety switch and switch bracket separately

Bolt for safety switches NP..AS/GP.../TP...A

Dimension drawings

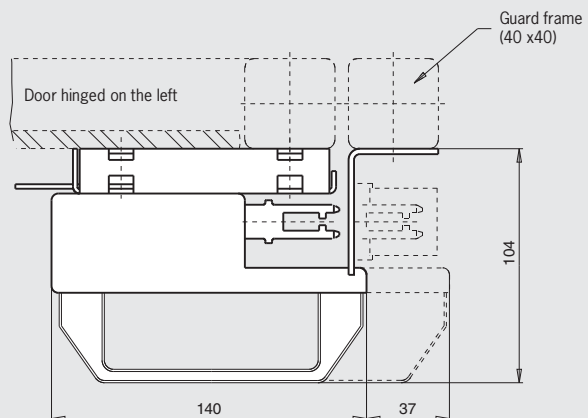
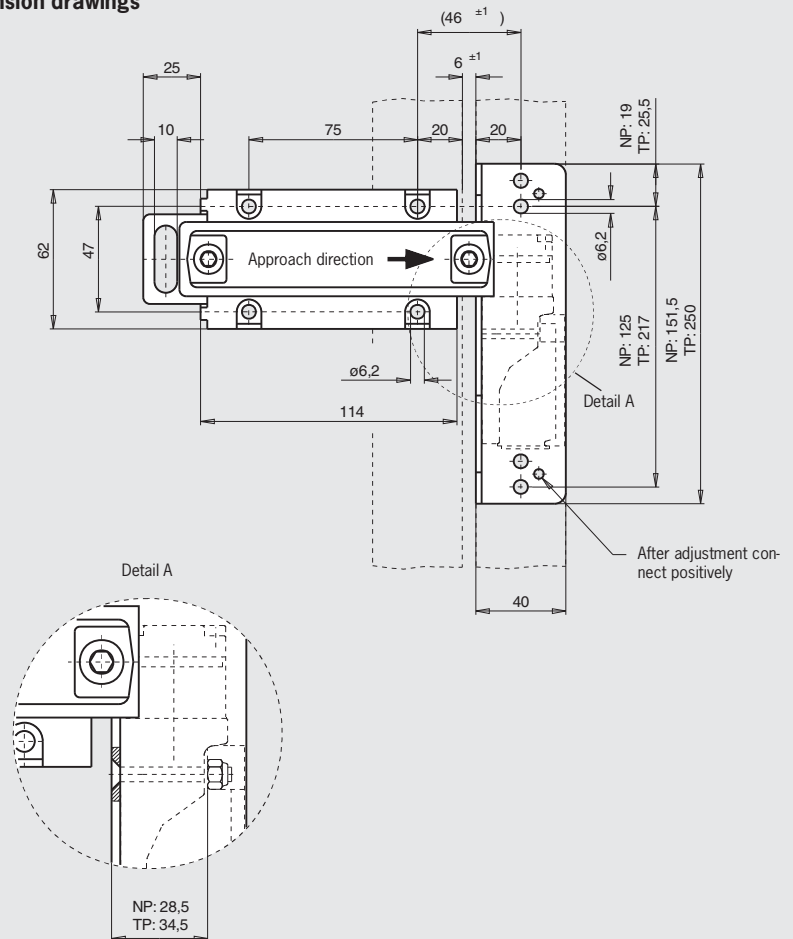

Ordering table

Designation	Detent mechanism	Version	Order no.
Bolt 0 NP/TP	Without	For doors hinged on the right or left (also for GP)	073535 Bolt 0 NP/TP
Bolt 1 NP/TP	1 x detent mechanism closed	for doors hinged on the right or left (also for GP)	073536 Bolt 1 NP/TP
Switch bracket NP		Separate	073538 Switch bracket NP
Switch bracket TP		Separate (also for GP)	073539 Switch bracket TP

Bolts for guards for safety switches GP and TP

- ▶ Material: Die-cast aluminum
- ▶ Lever for escape release from the danger zone (optional)
- ▶ For doors hinged on the right or left

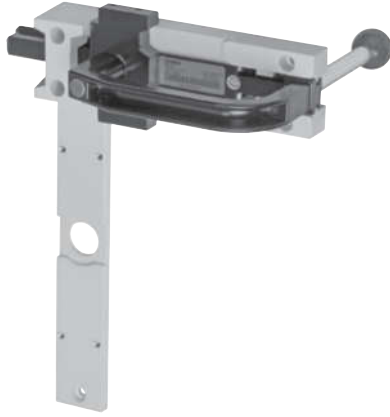

Special features

(only for bolt BTC-T/GP-S-TH-01-F with escape release)

- ▶ Bolt with detent mechanism
Bolt latches in open position to prevent unintentional closing of the bolt. Unlocked by pressing the knob
- ▶ Lever for escape release from the danger zone (optional)

Features

- ▶ Easily fitted to standard aluminum profiles and machine covers by screw connection
- ▶ Distinctive yellow color for easy recognition
- ▶ Rugged construction for heavy doors
- ▶ No additional door handle necessary

Notes

- ▶ The bolts are suitable only for the series **TP...A** and **GP**
- ▶ Actuator included
- ▶ Order safety switch separately

Bolt for safety switches GP.../TP...A/TP..A.-C1743/TP...A.-C1993

Dimension drawings (here: shown with escape release)

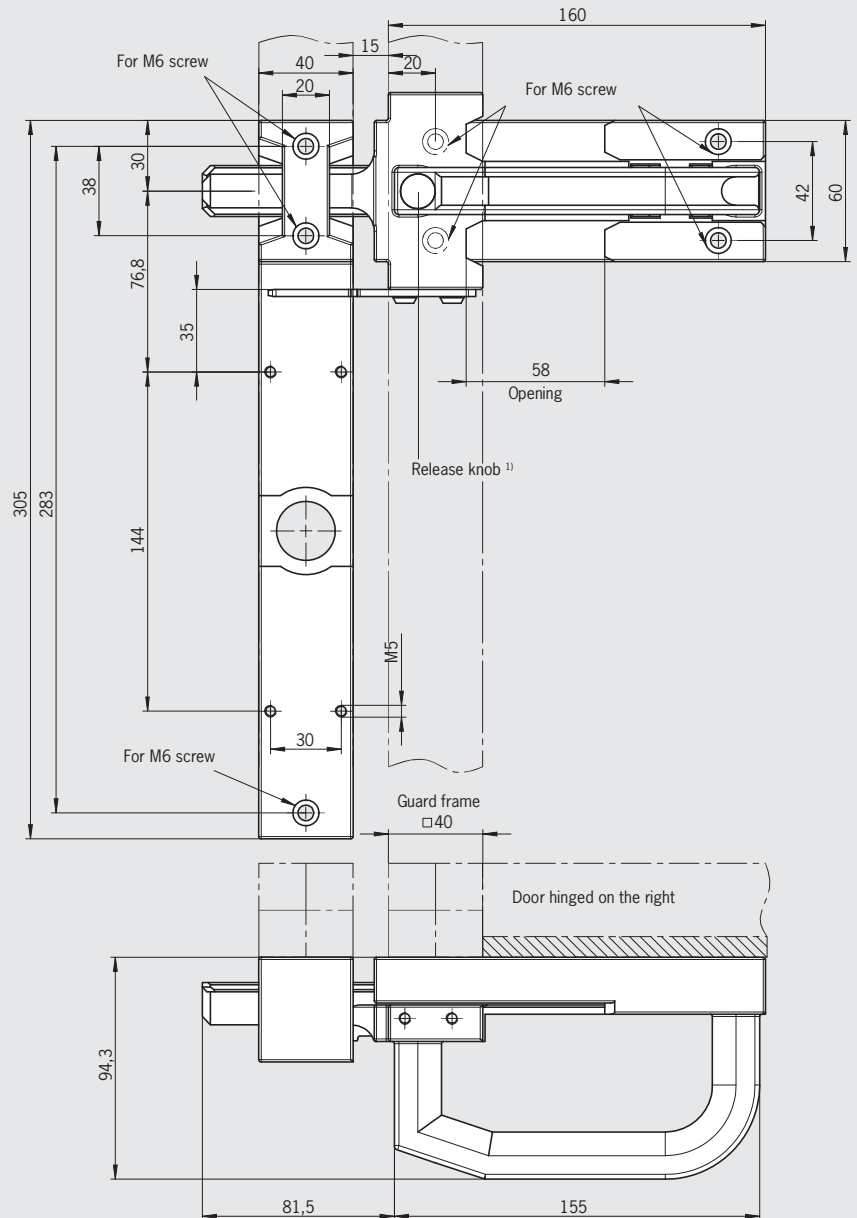

1) Bolt with detent mechanism (only for bolts BTC-T/GP-S-TH-01-F with escape release):
latches in open position and prevents unintentional closing of the bolt.
Unlocked by pressing the knob

Ordering table

Designation	Detent mechanism	Version	Order no.
Bolt BTC-T/GP-S-TH-01-F	1 x detent mechanism closed	For doors hinged on the right or left with escape release	106302 Bolt BTC-T/GP-S-TH-01-F
Bolt BTC-T/GP-S-TH-00-X	without	For doors hinged on the right or left without escape release	106301 Bolt BTC-T/GP-S-TH-00-X

Bolts for guards for safety switches STP/STA/SGP/SGA

- ▶ Lever for escape release from the danger zone (optional)

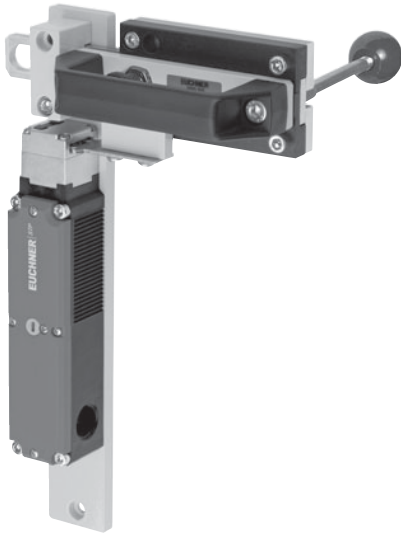

Special features

(only for bolt S-AF and S-CF with escape release)

- ▶ Bolt with detent mechanism
Bolt latches in open position to prevent unintentional closing of the bolt
- ▶ Lever for escape release from the danger zone (optional)

Features

- ▶ Easily fitted to standard aluminum profiles and machine covers by screw connection
- ▶ Distinctive yellow color for easy recognition
- ▶ Rugged construction for heavy doors
- ▶ No additional door handle necessary
- ▶ Slot on the bolt permits attachment of padlocks

Notes

- ▶ The bolts are only suitable for the series **STP.../STA.../SGP.../SGA...**
- ▶ Actuator included
- ▶ Order safety switch separately

Bolt for safety switches STP.../STA.../SGP.../SGA...

Dimension drawings (here: shown with escape release)

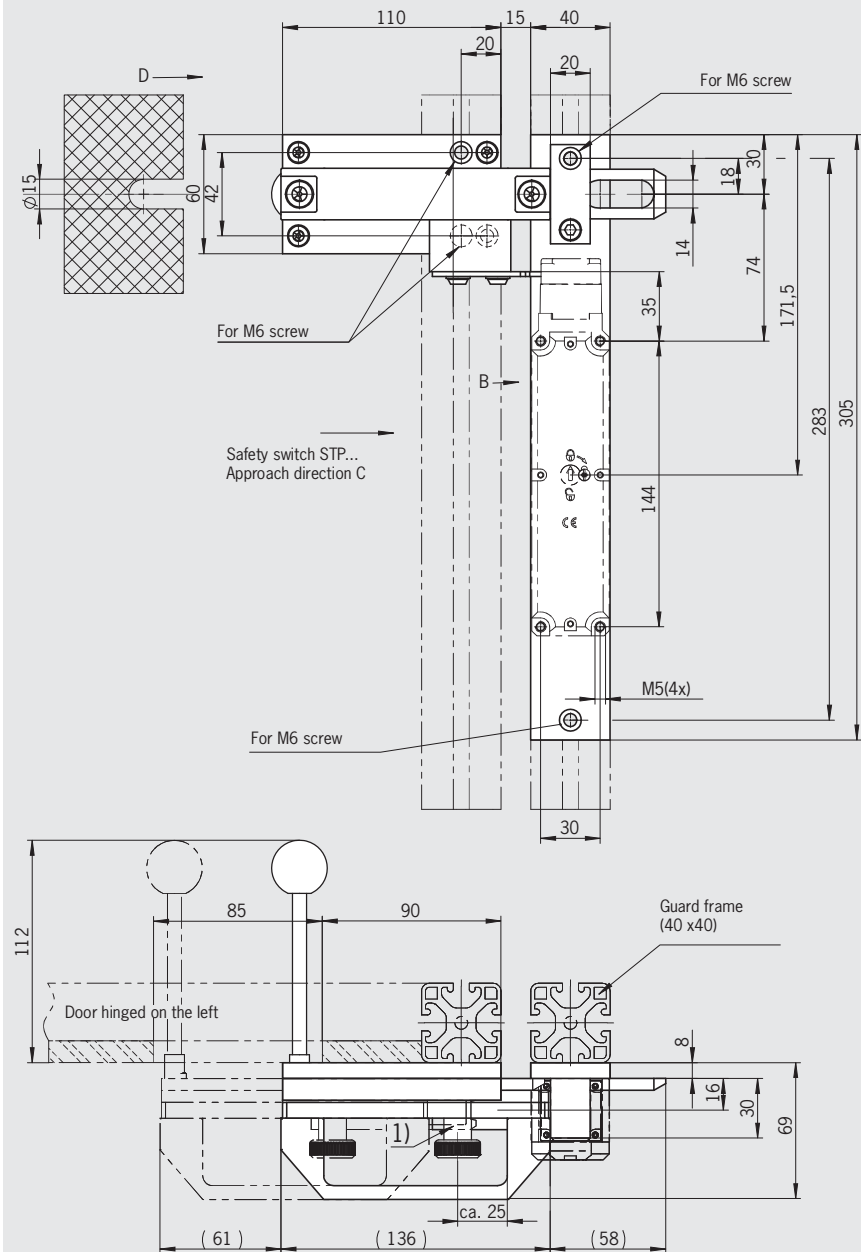

1) Bolt with detent mechanism (only for bolt S-AF and S-CF with escape release):
latches in open position and prevents unintentional closing of the bolt.
Unlocked by pulling the detent knob upward.

Ordering table

Designation	Detent mechanism	Version	Order no.
Bolt S-AF	Detent knob	For doors hinged on the right with escape release	096390 Bolt S-AF
Bolt S-CF	Detent knob	For doors hinged on the left with escape release	096391 Bolt S-CF
Bolt S-A	without	For doors hinged on the right without escape release	096384 Bolt S-A
Bolt S-C	without	For doors hinged on the left without escape release	096385 Bolt S-C

Bolts for guards for safety switches STP/STA/SGP/SGA

- ▶ **Material:** Die-cast aluminum
- ▶ **Lever for escape release from the danger zone (optional)**
- ▶ **For doors hinged on the right or left**



Special features

(only for bolt BTC-ST/G-S-TH-01-F with escape release)

- ▶ Bolt with detent mechanism
Bolt latches in open position to prevent unintentional closing of the bolt. Unlocked by pressing the knob
- ▶ Lever for escape release from the danger zone (optional)

Features

- ▶ Easily fitted to standard aluminum profiles and machine covers by screw connection
- ▶ Distinctive yellow color for easy recognition
- ▶ Rugged construction for heavy doors
- ▶ No additional door handle necessary

Notes

- ▶ The bolts are only suitable for the series **STP.../STA.../SGP.../SGA...**
- ▶ Actuator included
- ▶ Order safety switch separately

Bolt for safety switches STP.../STA.../SGP.../SGA...

Dimension drawings (here: shown with escape release)

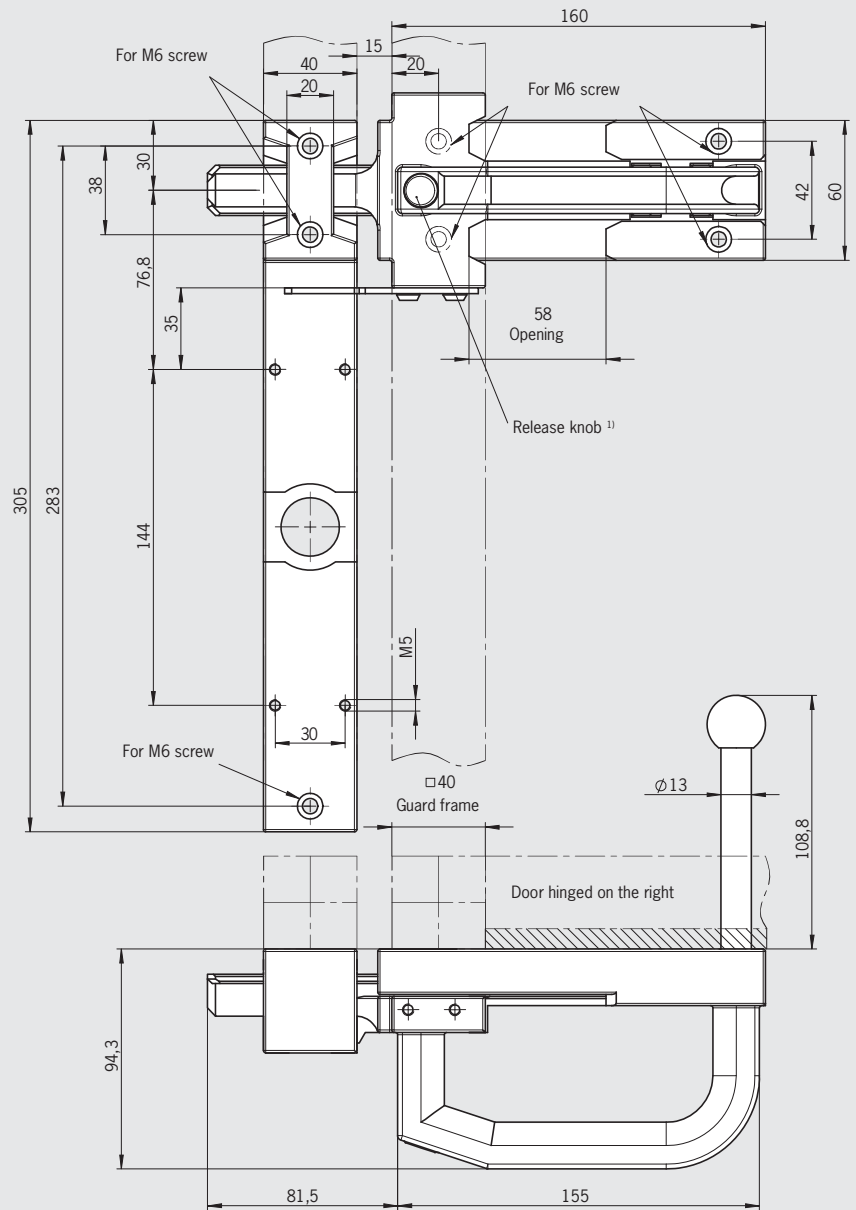

1) Bolt with detent mechanism (only for bolt BTC-ST/G-S-TH-01-F with escape release): latches in open position and prevents unintentional closing of the bolt. Unlocked by pressing the knob

Ordering table

Designation	Detent mechanism	Version	Order no.
Bolt BTC-ST/G-S-TH-01-F	1 x detent mechanism closed	For doors hinged on the right or left with escape release	106285 Bolt BTC-ST/G-S-TH-01-F
Bolt BTC-ST/G-S-TH-00-X	without	For doors hinged on the right or left without escape release	106284 Bolt BTC-ST/G-S-TH-00-X

Bolts for guards for safety switches GP, SGP, TP, STA and STP

- ▶ Material: reinforced plastic
- ▶ Lever for escape release from the danger zone
- ▶ For doors hinged on the left or right



Special features

- ▶ Bolt with detent mechanism (only bolts with escape release)
Bolt latches in open position to prevent unintentional closing of the bolt

Features

- ▶ Easily fitted to standard aluminum profiles and machine covers by screw connection
- ▶ Distinctive yellow color for easy recognition
- ▶ Rugged construction for heavy doors
- ▶ No additional door handle necessary
- ▶ Slot on the bolt permits attachment of padlocks

Notes

- ▶ Switch bracket **TP-GFK** must always be ordered separately
- ▶ Actuator included
- ▶ Order safety switch separately

Bolt for safety switches GP.../TP...A/TP.A.-C1743/TP...A.-C1993

Dimension drawings (here: shown with escape release)

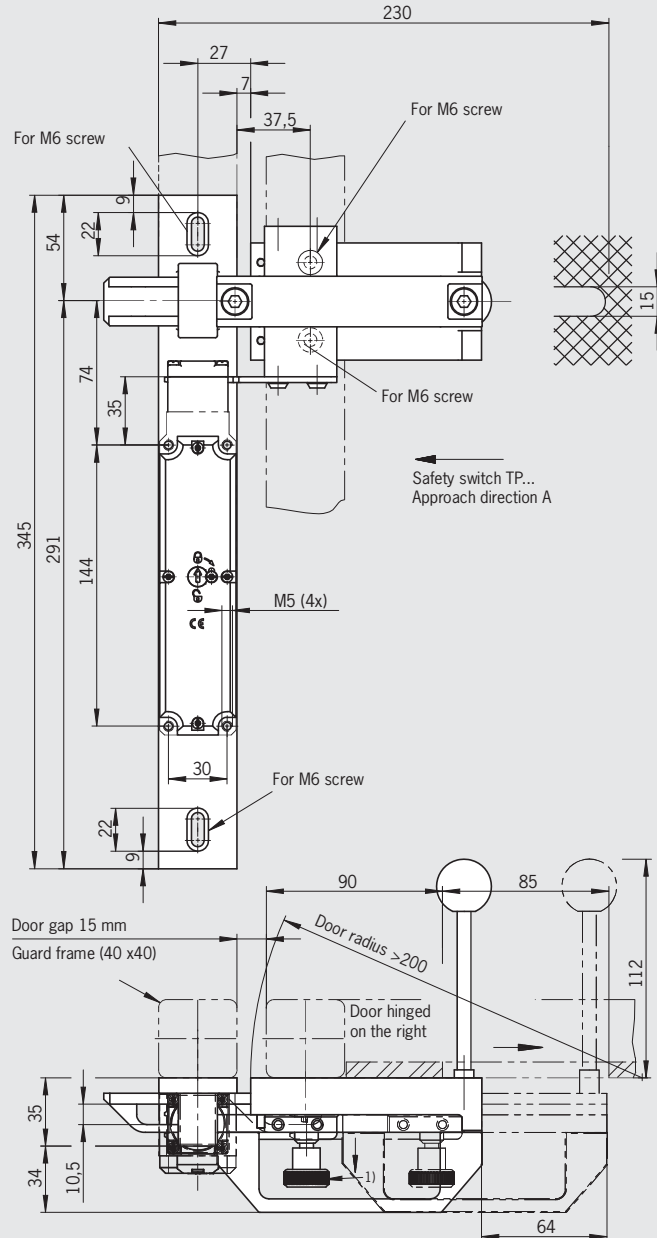

1) Bolt with detent mechanism (only for bolts with escape release):
latches in open position and prevents unintentional closing of the bolt.
Unlocked by pulling the detent knob upward.

Ordering table

Designation	Detent mechanism	Version	Order no.
Bolt TP-GFK-F	Detent knob	Bolt slide for doors hinged on the right or left with escape release (also for TP/GP)	097602 Bolt TP-GFK-F
Bolt TP-GFK	without	Bolt slide for doors hinged on the right or left without escape release (also for TP/GP)	096616 Bolt TP-GFK
Bolt STP-GFK	without	Bolt slide for doors hinged on the right or left without escape release (also for SGP/STP/STA)	098121 Bolt STP-GFK
Switch bracket TP-GFK		Switch bracket for TP/GP/SGP/STP/STA	096613 Switch bracket TP-GFK

List of plug connector suppliers

We provide no guarantee for the completeness and correctness of the ordering data given. The data was valid in October 2004. The related manufacturers reserve the right to make changes without notice. The plug connectors and accessories listed are also available from other manufacturers.

► Plug connectors and accessories

For plug connector	Function	Manufacturer's designation	
SVM5 5 pins	Female connector M12	99-0436-57-05 Cable socket	Binder www.binder-conector.de
	Female flange connector M12	09-3442-700-05 flange connector with flexible wires	
	Blanking plug M12	08-2425-000-000 Protective cap for socket with retaining strap	
CE5 3-pin + N + PE	Mating connector (socket)	CEE plug as per CEE standard	
C16-1 6 pins + PE	Female flange connector	T3107 500 Female receptacle	Amphenol-Tuchel www.amphenoltuchel.com
	Socket crimp contacts for C16-1, VPE 100 pcs.	VN02 016 0002 (1) Single contact, silver, 0.5-1.5 mm ²	
	Blanking plug	T6483 000 Protective cap for female receptacle	
HAN10 10 pins + PE	Flange connector 1 cable exit	19 20 010 0251 Socket housing 1 cable exit	Harting www.harting.com
	Socket contacts (installation for flange connector)	09 20 010 3101 Socket contact insert crimp connection	
	socket contacts for crimping	09 33 000 6220 Socket crimp contacts 0.5 mm ²	
	Blanking plug	09 20 010 5425 Cover	
RC17-Y coded 17 pins	female flange connector, solderable for male plug RC17Y)	RC-17S1Y122000 Flange plug connector 17-pin	Continers www.continers.com
	Blanking plug	RC-17P1N8A83NN Protective cap for socket with retaining strap	

► Crimp and extraction tools

For plug connector	Function	Manufacturer's designation	
SR6 and SR11	Crimp tool	932 507-002 XZC 0701	Hirschmann www.hirschmann.com
	extraction tool	931 812-001 XWA 164	
C16-1	Crimp tool	TA0500 + TA0000163 + TA0002016001 Crimp pliers, jaws and contact receptacle	Amphenol-Tuchel www.amphenoltuchel.com
	extraction tool	FG 0300 1461 extraction tool	
RC12	Crimp tool	RC-Z2504 Crimp pliers for machined contacts	Continers www.continers.com
	extraction tool	RC-Z2494 Extraction tool/insertion tool	
M23 (RC18)	Crimp tool	RC-Z2504 Crimp pliers for machined contacts	Continers www.continers.com
	extraction tool	RC-Z2274 / RC-Z2494 ¹⁾ extraction tool	
VP19	Crimp tool	T98143 DAK 83S-30 / 11-7576T3 Insertion tool	Litton/Veam www.littonveam.com
	extraction tool	46592-MT50 / 11-7576T3 Removal tool	
UT23	Crimp tool	Y16RCM Crimping tool for machined contacts	Burndy www.burndy.com
	extraction tool	RX2025GE1 Extraction tool	
TB24	Crimp tool	WT10-04 Crimp tool	Thomas & Betts www.ttb.com
	extraction tool	TRT16 Contact removal tool	

1) Only with option C1825

Overview

Safety switch series															
NM															Safety switch NM
	NM..VZ														Safety switch NM..VZ
		NP													Safety switch NP
			GP												Safety switch GP
				SGP											Safety switch SGP
					SGP-TW										Safety switch SGP-TW
						SGA									Safety switch SGA
							TP								Safety switch TP
								STP							Safety switch STP
									STP-BI						Safety switch STP-BI
										STP-TW					Safety switch STP-TW
											STA				Safety switch STA
												STA-TW			Safety switch STA-TW
													STM		Safety switch STM
														TK	Safety switch TK
															Accessories for safety switches

Safety switch series															Accessories	Page
NM	NM..VZ	NP	GP	SGP	SGP-TW	SGA	TP	STP STP-BI	STP-TW	STA	STA-TW	STM	TK			
•																122
	•															124
		•														125
			•													127
				•												128
					•											130
						•										131
							•									133
								•								137
									•							140
										•						142
											•					145
												•				147
													•			149
														•		151

Safety switch NM...



The technical data on switches and switching elements apply to all connections. Further technical data are given for the connection selected.

Reliability values acc. to EN ISO 13849-1

Parameter	Value	Unit
B _{10d}	20 x 10 ⁶ operating cycles	

Switch



Parameter	Value			Unit
Housing material	Reinforced thermoplastic			
Mechanical life	WO/RB	KB/HB	AV/AL/AG/AK	
	30 x 10 ⁶	20 x 10 ⁶	> 4 x 10 ⁶	operat. cycles
Weight	Approx. 0.1			kg
Actuator material	Plastic; hinged actuators steel (stainless)			
Approach speed, max.	60			m/min
Actuating force	15			N

Switching element

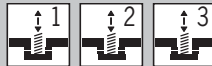

Parameter	Value				Unit
Switching principle	Slow-action switching contact				
Switching elements with 1 switching contact	ES01 1 NC ⊖				
Switching elements with 2 switching contacts	ES11 1 NC ⊖ + 1 NO	ES02 2 NC ⊖	ES12 2 NC ⊖ + 1 NO	ES03 3 NC ⊖	
Min. switching current at 24 V DC	1				mA
Switching voltage, min., at 10 mA	12				V
Contact material	Silver alloy, gold flashed				

Connection, cable entry M16 x 1.5



Parameter	Value	Unit
Ambient temperature	- 20 ... + 80	°C
Connection	Screw terminal	
Version	M16 x 1.5	
Connection cross-section	0.34 ... 1.5	mm ²
Degree of protection acc. to IEC 60529	IP 67	
Rated insulation voltage U _i	250	V AC/DC
Rated impulse withstand voltage U _{imp}	2.5	kV
Conventional thermal current I _{th}	4	A
Short circuit protection according to IEC 60269-1 (control circuit fuse)	4	A gG
Utilization category acc. to IEC 60947-5-1	AC-15 DC-13	I _e 4 A U _e 230 V I _e 4 A U _e 24 V

Connection, plug connector SM4 (M12)



Parameter	Value	Unit
Ambient temperature	- 20 ... + 60	°C
Connection	Plug connector	
Version	M12 (4-pin)	
Degree of protection acc. to IEC 60529	IP 67 ¹⁾	
Rated insulation voltage U _i	250	V AC/DC
Rated impulse withstand voltage U _{imp}	2.3	kV
Conventional thermal current I _{th}	1.5	A
Short circuit protection according to IEC 60269-1 (control circuit fuse)	4	A gG
Utilization category acc. to IEC 60947-5-1	AC-15 DC-13	I _e 4 A U _e 30 V I _e 4 A U _e 24 V

³⁾ Screwed tight with the related plug connector (see page 103)

Travel diagram NM.WO/NM.RB

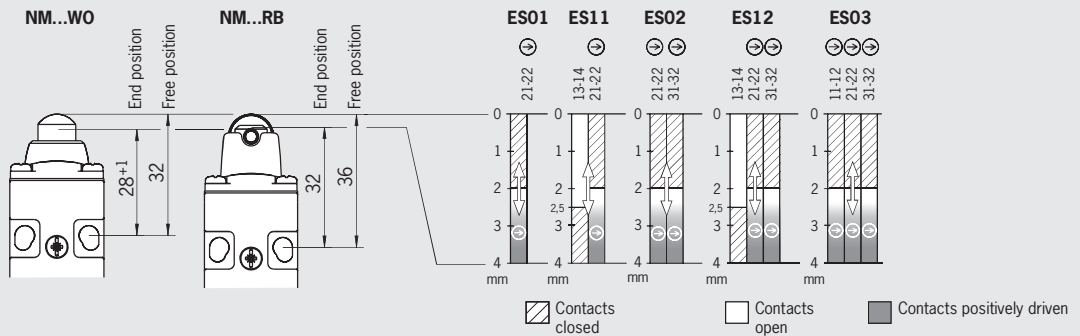

Travel diagram NM.KB

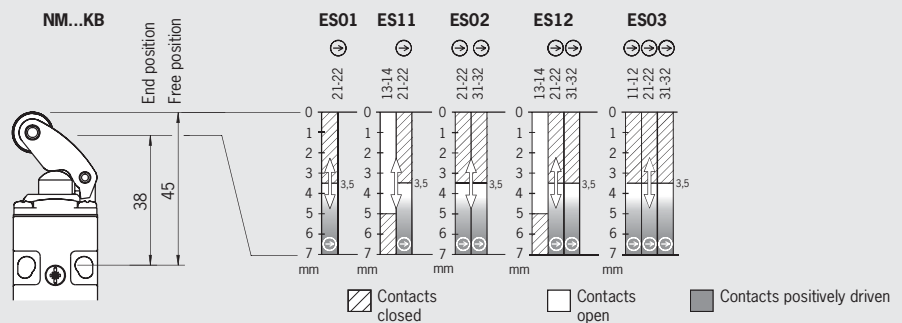

Travel diagram NM.HB

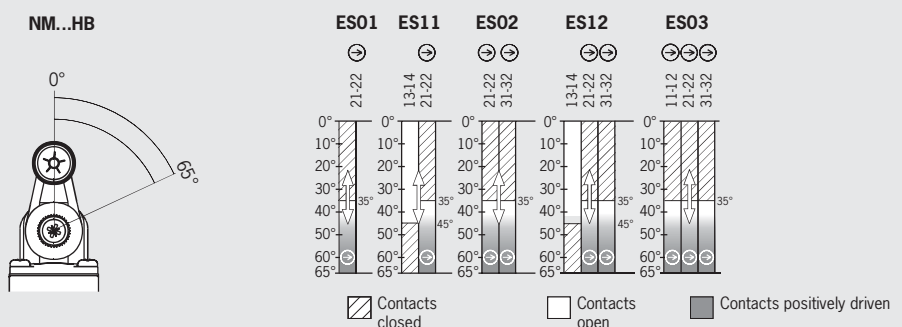

Travel diagram NM.AV/NM.AL/NM.AG/NM.AK

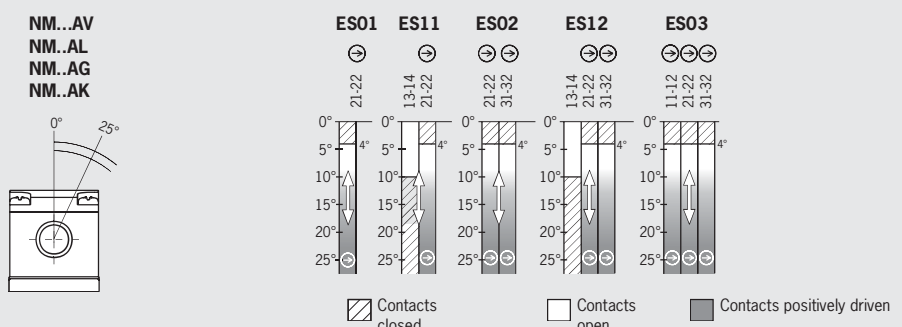

Safety switch NM..VZ



The technical data on switches and switching elements apply to all connections. Further technical data are given for the connection selected.

Reliability values acc. to EN ISO 13849-1

Parameter	Value	Unit
B10d	4 x 10 ⁶ operating cycles	

Switch



Parameter	Value	Unit
Housing material	Reinforced thermoplastic	
Mechanical life	10 ⁶ operating cycles	
Weight	Approx. 0.1	kg
Approach speed, max.	20	m/min
Actuating force	10	N
Extraction force	10	N
Retention force	2	N
Insertion depth	necessary minimum travel	20
	permissible overtravel	4

Switching element

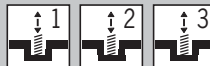

Parameter	Value	Unit
Switching principle	Slow-action switching contact	
Switching elements with 1 switching contact	ES01 1 NC ⊕	
Switching elements with 2 switching contacts	ES11 1 NC ⊕ + 1 NO ES02 2 NC ⊕ ES12 2 NC ⊕ + 1 NO ES03 3 NC ⊕	
Min. switching current at 24 V DC	1	mA
Switching voltage, min., at 10 mA	12	V
Contact material	Silver alloy, gold flashed	

Connection, cable entry M16 x 1.5



Parameter	Value	Unit
Ambient temperature	- 20 ... + 80	°C
Connection	Screw terminal	
Version	M16 x 1.5	
Connection cross-section	0.34 ... 1.5	mm ²
Degree of protection acc. to IEC 60529	IP 67	
Rated insulation voltage U _i	250	V AC/DC
Rated impulse withstand voltage U _{imp}	2.5	kV
Conventional thermal current I _{th}	4	A
Short circuit protection according to IEC 60269-1 (control circuit fuse)	4	A gG
Utilization category acc. to IEC 60947-5-1	AC-15	I _e 4 A U _e 230 V
	DC-13	I _e 4 A U _e 24 V

Connection, plug connector SM4 (M12)



Parameter	Value	Unit
Ambient temperature	- 20 ... + 60	°C
Connection	Plug connector	
Version	M12 (4-pin)	
Degree of protection acc. to IEC 60529	IP 67 ¹⁾	
Rated insulation voltage U _i	250	V AC/DC
Rated impulse withstand voltage U _{imp}	2.3	kV
Conventional thermal current I _{th}	1.5	A
Short circuit protection according to IEC 60269-1 (control circuit fuse)	4	A gG
Utilization category acc. to IEC 60947-5-1	AC-15	I _e 4 A U _e 30 V
	DC-13	I _e 4 A U _e 24 V

3) Screwed tight with the related plug connector (see page 103)

Safety switch NP

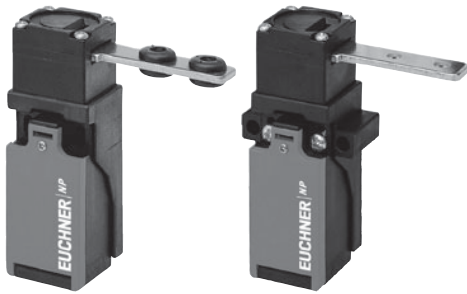



The technical data on switches and switching elements apply to all connections. Further technical data are given for the connection selected.

Reliability values acc. to EN ISO 13849-1

Parameter	Value	Unit
B _{10d}	3 x 10 ⁶ operating cycles	

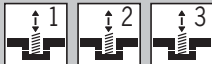
Switch			Unit
Parameter			Value
Housing material			Reinforced thermoplastic
Mechanical life			10 ⁶ operating cycles
Ambient temperature			-20 ... +80 °C
Weight			Approx. 0.11 kg
Approach speed, max.			20 m/min
Actuating force			5 N
Extraction force			15 N
Retention force			2 N
Insertion depth (minimum required travel + permissible overtravel)	Standard actuator	Overtravel actuator	
Lateral approach direction (h)	28 + 2	28 + 7	mm
Approach direction from above (v)	29.5 + 1.5	29.5 + 7 Only with adapter NP-K Order No. 074578 / page 100	mm

Switching element			Unit
Parameter			Value
Switching principle			Slow-action switching contact
Switching elements with 1 switching contact			618 1 NC ⇄
Switching elements with 2 switching contacts	628 1 NC ⇄ + 1 NO	638 2 NC ⇄	
Switching elements with 3 switching contacts			648 2 NC ⇄ + 1 NO
Min. switching current at 24 V DC			30 mA
Switching voltage, min., at 10 mA			24 V
Contact material			Silver alloy

Connection, cable entry M20 x 1.5			Unit
Parameter			Value
Connection			Screw terminal
Version			M20 x 1.5
Connection cross-section			0.34 ... 1.5 mm ²
Degree of protection acc. to IEC 60529			IP 67
Rated insulation voltage U _i			250 V AC/DC
Rated impulse withstand voltage U _{imp}			2.5 kV
Conventional thermal current I _{th}			4 A
Short circuit protection according to IEC 60269-1 (control circuit fuse)			4 A gG
Utilization category acc. to IEC 60947-5-1	AC-15		I _e 4 A U _e 230 V
	DC-13		I _e 4 A U _e 24 V

Connection, plug connector SM4 (M12)



Parameter		Value	Unit
Ambient temperature		- 20 ... + 60	°C
Connection		Plug connector	
Version		M12 (4-pin)	
Degree of protection acc. to IEC 60529		IP 67 ¹⁾	
Rated insulation voltage U _i		250	V AC/DC
Rated impulse withstand voltage U _{imp}		2.3	kV
Conventional thermal current I _{th}		1.5	A
Short circuit protection according to IEC 60269-1 (control circuit fuse)		4	A gG
Utilization category acc. to IEC 60947-5-1	AC-15	I _e 4 A U _e 30 V	
	DC-13	I _e 4 A U _e 24 V	

3) Screwed tight with the related plug connector (see page 103)

Connection, plug connector SR6



Parameter		Value	Unit
Connection		Plug connector	
Version		6-pin + PE	
Degree of protection acc. to IEC 60529		IP 65 ¹⁾	
Rated insulation voltage U _i		250	V AC/DC
Rated impulse withstand voltage U _{imp}		2.5	kV
Conventional thermal current I _{th}		4	A
Short circuit protection according to IEC 60269-1 (control circuit fuse)		4	A gG
Utilization category acc. to IEC 60947-5-1	AC-15	I _e 4 A U _e 230 V	
	DC-13	I _e 4 A U _e 24 V	

1) Screwed tight with the related plug connector (see page 104)

Safety switch GP



The technical data on switches and switching elements apply to all connections. Further technical data are given for the connection selected.

Reliability values acc. to EN ISO 13849-1

Parameter	Value	Unit
B _{10d}	3 x 10 ⁶ operating cycles	

Switch



Parameter	Value	Unit	
Housing material	Reinforced thermoplastic		
Mechanical life	2 x 10 ⁶ operating cycles		
Ambient temperature	-20 ... +80	°C	
Weight	Approx. 0.16	kg	
Approach speed, max.	20	m/min	
Actuating force	5	N	
Extraction force	15	N	
Retention force	2	N	
Insertion depth (minimum required travel + permissible overtravel)	Standard actuator	Overtravel actuator	
Lateral approach direction (h)	28 + 2	28 + 7	mm
Approach direction from above (v)	29.5 + 1.5	29.5 + 7	mm

Switching element

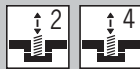

Parameter	Value	Unit	
Switching principle	Slow-action switching contact		
Switching elements with 2 switching contacts	528 1 NC ⊖ + 1 NO	538 2 NC ⊖	
Switching elements with 4 switching contacts	2121 4 NC ⊖	2131 3 NC ⊖ + 1 NO	3131 2 NC ⊖ + 2 NO
Min. switching current at 24 V DC	1	mA	
Switching voltage, min., at 10 mA	12	V	
Contact material	Silver alloy, gold flashed		

Connection, cable entry M20 x 1.5



Parameter	Value	Unit
Connection	Screw terminal	
Version	M20 x 1.5	
Connection cross-section	0.34 ... 1.5	mm ²
Degree of protection acc. to IEC 60529	IP 67	
Rated insulation voltage U _i	250	V AC/DC
Rated impulse withstand voltage U _{imp}	2.5	kV
Conventional thermal current I _{th}	4	A
Short circuit protection according to IEC 60269-1 (control circuit fuse)	4	A gG
Utilization category acc. to IEC 60947-5-1	AC-15	I _e 4 A U _e 230 V
	DC-13	I _e 4 A U _e 24 V

Connection, plug connector SR11



Parameter	Value	Unit
Connection	Plug connector	
Version	11-pin + PE	
Degree of protection acc. to IEC 60529	IP 65 ¹⁾	
Rated insulation voltage U _i	50	V AC/DC
Rated impulse withstand voltage U _{imp}	1.5	kV
Conventional thermal current I _{th}	4	A
Short circuit protection according to IEC 60269-1 (control circuit fuse)	4	A gG
Utilization category acc. to IEC 60947-5-1	AC-15	I _e 4 A U _e 50 V
	DC-13	I _e 4 A U _e 24 V

1) Screwed tight with the related plug connector (see page 104)

Safety switch SGP



The technical data on switches and switching elements apply to all connections. Further technical data are given for the connection selected.





Reliability values acc. to EN ISO 13849-1

Parameter	Value	Unit
B10d	3 x 10 ⁶ operating cycles	

Switch			Value	Unit
Material	Housing		Reinforced thermoplastic	
	Actuating head		Die-cast aluminum	
	Cam in actuating head		Stainless steel	
Mechanical life			2 x 10 ⁶ operating cycles	
Ambient temperature			- 20 ... + 80	°C
Weight			Approx. 0.16	kg
Approach speed, max.			20	m/min
Actuating force			25	N
Extraction force			25	N
Retention force			10	N
Insertion depth (minimum required travel + permissible overtravel)	Actuator S standard		Actuator L for insertion funnel	
Lateral approach direction (h)	24.5 + 5		28.5 + 5	mm
Approach direction from above (v)	24.5 + 5		28.5 + 5	mm

Switching element				Value	Unit
Switching principle				Slow-action switching contact	
Switching elements with 2 switching contacts				538 2 NC ⊕	
Switching elements with 4 switching contacts	2121 4 NC ⊕		2131 3 NC ⊕ + 1 NO	3131 2 NC ⊕ + 2 NO	
Min. switching current at 24 V DC				1	mA
Switching voltage, min., at 10 mA				12	V
Contact material				Silver alloy, gold flashed	

Connection, cable entry M20 x 1.5			Value	Unit
Connection			Screw terminal	
Version			M20 x 1.5	
Connection cross-section			0.34 ... 1.5	mm ²
Degree of protection acc. to IEC 60529			IP 67	
Rated insulation voltage U _i			250	V AC/DC
Rated impulse withstand voltage U _{imp}			2.5	kV
Conventional thermal current I _{th}			4	A
Short circuit protection according to IEC 60269-1 (control circuit fuse)			4	A gG
Utilization category acc. to IEC 60947-5-1	AC-15		I _e 4 A U _e 230 V	
	DC-13		I _e 4 A U _e 24 V	

Connection, plug connector SR6				
Parameter			Value	Unit
Connection			Plug connector	
Version			6-pin + PE	
Degree of protection acc. to IEC 60529			IP 65 ¹⁾	
Rated insulation voltage U _i			250	V AC/DC
Rated impulse withstand voltage U _{imp}			2.5	kV
Conventional thermal current I _{th}			4	A
Short circuit protection according to IEC 60269-1 (control circuit fuse)			4	A gG
Utilization category acc. to IEC 60947-5-1		AC-15	I _e 4 A U _e 230 V	
		DC-13	I _e 4 A U _e 24 V	

1) Screwed tight with the related plug connector (see page 104)

Connection, plug connector SR11				
Parameter			Value	Unit
Connection			Plug connector	
Version			11-pin + PE	
Degree of protection acc. to IEC 60529			IP 65 ¹⁾	
Rated insulation voltage U _i			50	V AC/DC
Rated impulse withstand voltage U _{imp}			1.5	kV
Conventional thermal current I _{th}			4	A
Short circuit protection according to IEC 60269-1 (control circuit fuse)			4	A gG
Utilization category acc. to IEC 60947-5-1		AC-15	I _e 4 A U _e 50 V	
		DC-13	I _e 4 A U _e 24 V	

1) Screwed tight with the related plug connector (see page 104)

Safety switch SGP-TW



The technical data on switches and switching elements apply to all connections. Further technical data are given for the connection selected.

Reliability values acc. to EN ISO 13849-1

Parameter	Value	Unit
B10d	2 x 10 ⁶ operating cycles	

Switch



Parameter	Value	Unit
Material	Housing	Reinforced thermoplastic
	Actuating head	Die-cast aluminum
	Cam in actuating head	Stainless steel
Mechanical life	1 x 10 ⁶ operating cycles	
Ambient temperature	- 20 ... + 80	°C
Weight	Approx. 0.32	kg
Approach speed, max.	20	m/min
Actuating force	25	N
Extraction force	25	N
Retention force	10	N
Insertion depth (minimum required travel + permissible overtravel)	Actuator S standard	
Lateral approach direction (h)	24.5 + 5	mm
Approach direction from above (v)	24.5 + 5	mm

Switching element



Parameter	Value	Unit
Switching principle	Slow-action switching contact	
Switching elements with 4 switching contacts	2131 3 NC ⊖ + 1 NO	
Min. switching current at 24 V DC	1	mA
Switching voltage, min., at 10 mA	12	V
Contact material	Silver alloy, gold flashed	

Connection, cable entry M20 x 1.5



Parameter	Value	Unit
Connection	Screw terminal	
Version	M20 x 1.5	
Connection cross-section	0.34 ... 1.5	mm ²
Degree of protection acc. to IEC 60529	IP 67	
Rated insulation voltage U _i	250	V AC/DC
Rated impulse withstand voltage U _{imp}	2.5	kV
Conventional thermal current I _{th}	4	A
Short circuit protection according to IEC 60269-1 (control circuit fuse)	4	A gG
Utilization category acc. to IEC 60947-5-1	AC-15	I _e 4 A U _e 230 V
	DC-13	I _e 4 A U _e 24 V

Safety switch SGA





The technical data on switches and switching elements apply to all connections. Further technical data are given for the connection selected.

Reliability values acc. to EN ISO 13849-1

Parameter	Value	Unit
B _{10d}	3 x 10 ⁶ operating cycles	

Switch			Value	Unit
Material	Housing		Reinforced thermoplastic	
Mechanical life			1 x 10 ⁶ operating cycles	
Ambient temperature			- 20 ... + 80	°C
Weight			Approx. 0.275	kg
Approach speed, max.			20	m/min
Actuating force			25	N
Extraction force			25	N
Retention force			10	N
Insertion depth (minimum required travel + permissible overtravel)			Actuator S standard	
Lateral approach direction (h)			24.5 + 5	mm
Approach direction from above (v)			24.5 + 5	mm

Switching element			Value	Unit
Switching principle			Slow-action switching contact	
Switching elements with 4 switching contacts			2121 4 NC \Rightarrow	2131 3 NC \Rightarrow + 1 NO
Min. switching current at 24 V DC			1	mA
Switching voltage, min., at 10 mA			12	V
Contact material			Silver alloy, gold flashed	

Connection, cable entry M20 x 1.5			Value	Unit
Connection			Screw terminal	
Version			M20 x 1.5	
Connection cross-section			0.34 ... 1.5	mm ²
Degree of protection acc. to IEC 60529			IP 67	
Rated insulation voltage U _i			250	V AC/DC
Rated impulse withstand voltage U _{imp}			2.5	kV
Conventional thermal current I _{th}			4	A
Short circuit protection according to IEC 60269-1 (control circuit fuse)			4	A gG
Utilization category acc. to IEC 60947-5-1	AC-15		I _e 4 A U _e 230 V	
	DC-13		I _e 4 A U _e 24 V	

Connection, plug connector SR11



Parameter		Value	Unit
Connection		Plug connector	
Version		11-pin + PE	
Degree of protection acc. to IEC 60529		IP 65 ¹⁾	
Rated insulation voltage U_i		50	V AC/DC
Rated impulse withstand voltage U_{imp}		1.5	kV
Conventional thermal current I_{th}		4	A
Short circuit protection according to IEC 60269-1 (control circuit fuse)		4	A gG
Utilization category acc. to IEC 60947-5-1	AC-15	I_e 4 A U_e 50 V	
	DC-13	I_e 4 A U_e 24 V	

1) Screwed tight with the related plug connector (see page 104)

Connection, plug connector M23 (RC18)



Parameter		Value	Unit
Connection		Plug connector	
Version		18-pin + PE	
Degree of protection acc. to IEC 60529		IP 65 ^{1) 2)}	
Rated insulation voltage U_i		110	V AC/DC
Rated impulse withstand voltage U_{imp}		2.5	kV
Conventional thermal current I_{th}		4	A
Short circuit protection according to IEC 60269-1 (control circuit fuse)		4	A gG
Utilization category acc. to IEC 60947-5-1	AC-15	I_e 4 A U_e 110 V	
	DC-13	I_e 4 A U_e 24 V	

1) Screwed tight with the related plug connector (see page 105 - 106)

2) Version SGA...EXT5 with 2 pushbuttons IP 54



Safety switch TP... with guard locking and guard locking monitoring





The technical data on switches, switching elements and guard locking apply to all connections. Further technical data are given for the connection selected.

Reliability values acc. to EN ISO 13849-1

Parameter	Value	Unit
B _{10d}	3 x 10 ⁶ operating cycles	

Switch 			
Parameter	Value	Unit	
Housing material	Reinforced thermoplastic		
Mechanical life	1 x 10 ⁶ operating cycles		
Ambient temperature	- 20 ... + 55	°C	
Weight	Approx. 0.5	kg	
Approach speed, max.	20	m/min	
Actuating force	10	N	
Extraction force (not locked)	20	N	
Retention force	10	N	
Locking force, max.	Approach direction		
	Top (v)	Side (h)	
	1,300 (800 for door unlock request contact)	1,300 (800 for door unlock request contact)	
Locking force F _{zh} in accordance with test principles GSET-19	Approach direction		
	From top (v)	Side (h)	
	1,000	1,000	
Insertion depth (minimum required travel + permissible overtravel)	Actuator S standard	Actuator L for insertion funnel	
Lateral approach direction (h)	28 + 2	28 + 7	mm
Approach direction from above (v)	29.5 + 1.5	 only on TP...K...29.5 + 7	mm

Switching element 				
Parameter	Value			Unit
Switching principle	Slow-action switching contact			
Switching elements with 2 switching contacts	528 1 NC ⊕ + 1 NO	537 1 NC ⊕ + 1 NC	538 2 NC ⊕	
	4120 2 NC ⊕ + 1 NO			
Switching elements with door unlock request contact	2131 2 NC ⊕ + 1 NO + 1 NC	4121 2 NC ⊕ + 1 NC + 1 NO	4131 2 NC ⊕ + 2 NO	4141 4 NC ⊕
Min. switching current at 24 V DC	1			mA
Switching voltage, min., at 10 mA	12			V
Contact material	Silver alloy, gold flashed			

Guard locking 				
Parameter	Value			Unit
Solenoid operating voltage	AC/DC 24 V +10/-15%	AC 110 V +10/-15%	AC 230 V +10/-15%	
Connection	Reverse polarity protected, integrated bridge rectifier			
Duty cycle	100			%
Power consumption	8			W

Connection, cable entry M20 x 1.5 		
Parameter	Value	Unit
Connection	Screw terminal	
Version	M20 x 1.5	
Connection cross-section	0.34 ... 1.5	mm ²
Degree of protection acc. to IEC 60529	IP 67	
Rated insulation voltage U _i	250	V AC/DC
Rated impulse withstand voltage U _{imp}	2.5	kV
Conventional thermal current I _{th}	4	A
Short circuit protection according to IEC 60269-1 (control circuit fuse)	4	A gG
Utilization category acc. to IEC 60947-5-1	AC-15	I _e 4 A U _e 230 V
	DC-13	I _e 4 A U _e 24 V

Connection, plug connector SR6



Parameter		Value	Unit
Connection		Plug connector	
Version		6-pin + PE	
Degree of protection acc. to IEC 60529		IP 65 ¹⁾	
Rated insulation voltage U _i		250	V AC/DC
Rated impulse withstand voltage U _{imp}		2.5	kV
Conventional thermal current I _{th}		4	A
Short circuit protection according to IEC 60269-1 (control circuit fuse)		4	A gG
Utilization category acc. to IEC 60947-5-1	AC-15	I _e 4 A U _e 230 V	
	DC-13	I _e 4 A U _e 24 V	

1) Screwed tight with the related plug connector (see page 104)

Connection, plug connector SM8 (M12)



Parameter		Value	Unit
Connection		Plug connector	
Version		8-pin	
Degree of protection acc. to IEC 60529		IP 65 ¹⁾	
Rated insulation voltage U _i		30	V AC/DC
Rated impulse withstand voltage U _{imp}		1.5	kV
Conventional thermal current I _{th}		1	A
Short circuit protection according to IEC 60269-1 (control circuit fuse)		1	A gG
Utilization category acc. to IEC 60947-5-1	AC-15	I _e 1 A U _e 24 V	
	DC-13	I _e 4 A U _e 24 V	

1) Screwed tight with the related plug connector

Connection, plug connector SR11



Parameter		Value	Unit
Connection		Plug connector	
Version		11-pin + PE	
Degree of protection acc. to IEC 60529		IP 65 ¹⁾	
Rated insulation voltage U _i		50	V AC/DC
Rated impulse withstand voltage U _{imp}		1.5	kV
Conventional thermal current I _{th}		4	A
Short circuit protection according to IEC 60269-1 (control circuit fuse)		4	A gG
Utilization category acc. to IEC 60947-5-1	AC-15	I _e 4 A U _e 50 V	
	DC-13	I _e 4 A U _e 24 V	

1) Screwed tight with the related plug connector (see page 104)

Connection, plug connector BHA12



Parameter		Value	Unit
Connection		Plug connector	
Version		12-pin	
Degree of protection acc. to IEC 60529		IP 65 ^{1) 2)}	
Rated insulation voltage U _i		50	V AC/DC
Rated impulse withstand voltage U _{imp}		2.5	kV
Conventional thermal current I _{th}		2	A
Short circuit protection according to IEC 60269-1 (control circuit fuse)		2	A gG
Utilization category acc. to IEC 60947-5-1	AC-15	I _e 2 A U _e 50 V	
	DC-13	I _e 2 A U _e 24 V	

1) Screwed tight with the related plug connector (see page 107)

2) Version TP...EXT... with pushbutton/cover for indicators IP 54

Connection, plug connector M23 (RC18)				
Parameter			Value	Unit
Connection			Plug connector	
Version			18-pin + PE	
Degree of protection acc. to IEC 60529			IP 65 ¹⁾	
Rated insulation voltage U_i			110	V AC/DC
Rated impulse withstand voltage U_{imp}			2.5	kV
Conventional thermal current I_{th}			4	A
Short circuit protection according to IEC 60269-1 (control circuit fuse)			4	A gG
Utilization category acc. to IEC 60947-5-1	AC-15		I_e 4 A U_e 110 V	
	DC-13		I_e 4 A U_e 24 V	

1) Screwed tight with the related plug connector (see page 105 - 106)

Switching functions TP1/TP2 Without door monitoring contact

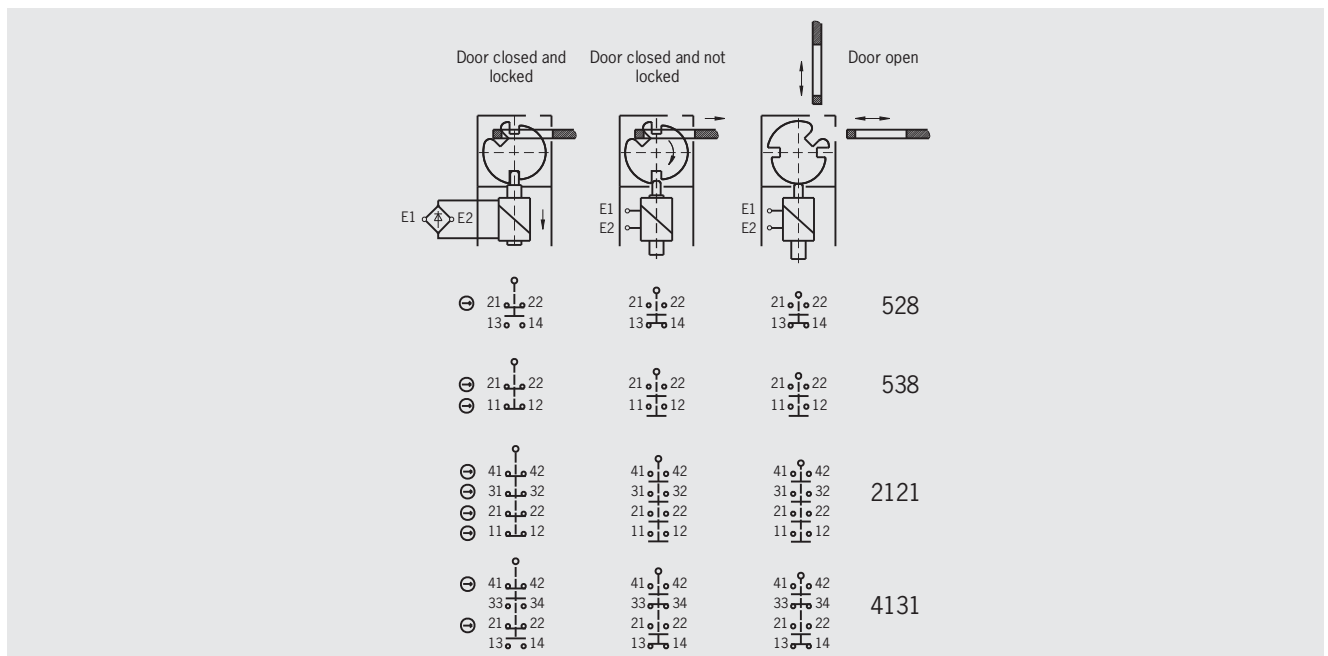

**Switching functions TP3/TP4
With door monitoring contact**

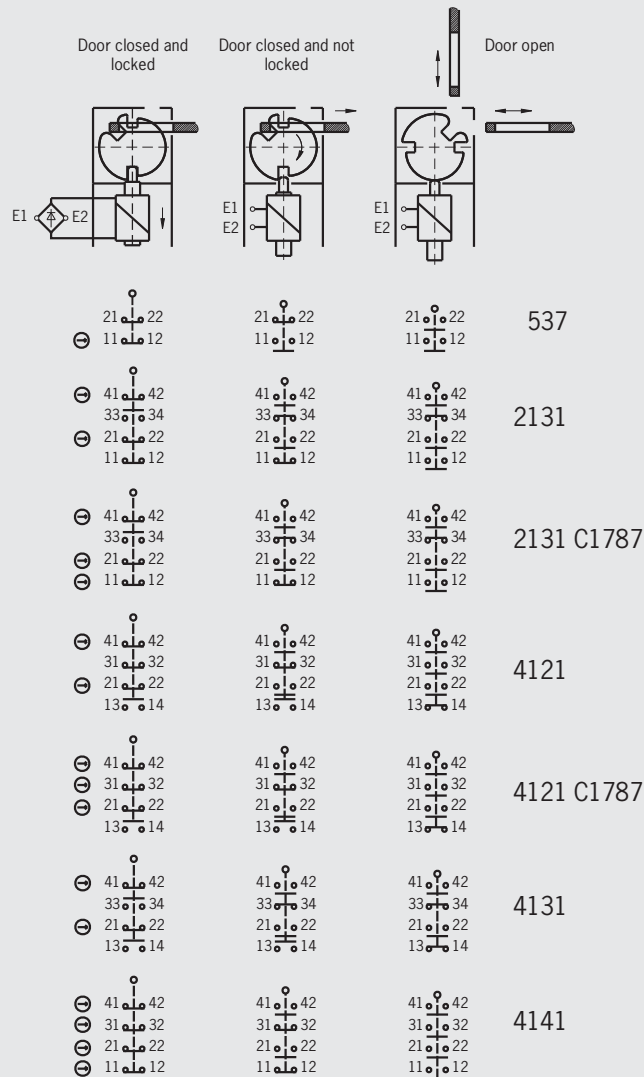

**Switching functions TP5/TP6
With door unlock request contact**

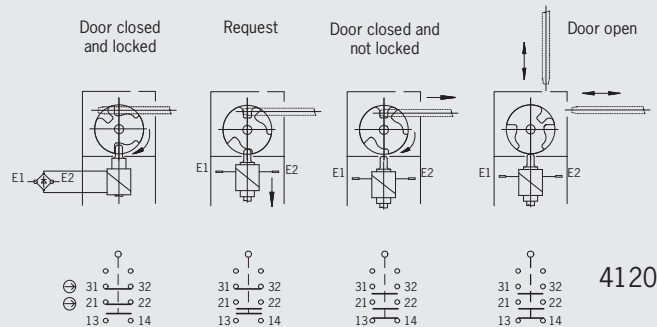

Safety switch STP.../STP-BI with guard locking and guard locking monitoring







The technical data on switches, switching elements and guard locking apply to all connections. Further technical data are given for the connection selected.

Reliability values acc. to EN ISO 13849-1

Parameter		Value	Unit
B _{10d}	STP	5 x 10 ⁶ operating cycles	
	STP-BI	2 x 10 ⁶ operating cycles	

Switch			Value	Unit
Material	Housing		Reinforced thermoplastic	
	Actuating head		Die-cast aluminum	
	Cam in actuating head		Stainless steel	
Mechanical life			1 x 10 ⁶ operating cycles	
Ambient temperature			- 20 ... + 55	°C
Weight			Approx. 0.5	kg
Approach speed, max.			20	m/min
Actuating force			35	N
Extraction force (not locked)			30	N
Retention force			20	N
Locking force, max.	Approach direction			
	From top (v)	Side (h)		N
Locking force F _{2h} in accordance with test principles GSET-19	Approach direction			
	From top (v)	Side (h)		N
Insertion depth (minimum required travel + permissible overtravel)	Actuator S standard			
	Actuator L for insertion funnel			
Lateral approach direction (h)			24.5 + 5	mm
Approach direction from above (v)			24.5 + 5	mm

Switching element				Value	Unit
Switching principle	Slow-action switching contact				
Switching elements with 2 switching contacts	528 1 NC ⊕ + 1 NO		537 1 NC ⊕ + 1 NC		
	538 2 NC ⊕				
Switching elements with 4 switching contacts	2131 2 NC ⊕ + 1 NO + 1 NC		4121 2 NC ⊕ + 1 NC + 1 NO		
	4131 2 NC ⊕ + 2 NO		4141 4 NC ⊕		
Min. switching current at 24 V DC	1				mA
Switching voltage, min., at 10 mA	12				V
Contact material	Silver alloy, gold flashed				

Guard locking				Value	Unit
Solenoid operating voltage				AC/DC 24 V +10/-15% AC 110 V +10/-15% AC 230 V +10/-15%	
Connection	Reverse polarity protected, integrated bridge rectifier				
Duty cycle	100				%
Power consumption	8				W

Connection, cable entry M20 x 1.5			Value	Unit
Connection	Screw terminal			
Version	M20 x 1.5			
Connection cross-section	0.34 ... 1.5			mm ²
Degree of protection acc. to IEC 60529	IP 67			
Rated insulation voltage U _i	250			V AC/DC
Rated impulse withstand voltage U _{imp}	2.5			kV
Conventional thermal current I _{th}	4			A
Short circuit protection according to IEC 60269-1 (control circuit fuse)	4			A gG
Utilization category acc. to IEC 60947-5-1	AC-15	I _e 4 A U _e 230 V		
	DC-13	I _e 4 A U _e 24 V		

Connection, plug connector SR11



Parameter		Value	Unit
Connection		Plug connector	
Version		11-pin + PE	
Degree of protection acc. to IEC 60529		IP 65 ¹⁾	
Rated insulation voltage U_i		50	V AC/DC
Rated impulse withstand voltage U_{imp}		1.5	kV
Conventional thermal current I_{th}		4	A
Short circuit protection according to IEC 60269-1 (control circuit fuse)		4	A gG
Utilization category acc. to IEC 60947-5-1	AC-15	I_e 4 A U_e 50 V	
	DC-13	I_e 4 A U_e 24 V	

1) Screwed tight with the related plug connector (see page 104)

Connection, plug connector M23 (RC18)



Parameter		Value	Unit
Connection		Plug connector	
Version		18-pin + PE	
Degree of protection acc. to IEC 60529		IP 65 ^{1) 2)}	
Rated insulation voltage U_i		110	V AC/DC
Rated impulse withstand voltage U_{imp}		2.5	kV
Conventional thermal current I_{th}		4	A
Short circuit protection according to IEC 60269-1 (control circuit fuse)		4	A gG
Utilization category acc. to IEC 60947-5-1	AC-15	I_e 4 A U_e 110 V	
	DC-13	I_e 4 A U_e 24 V	

1) Screwed tight with the related plug connector (see page 105 - 106)

2) Version STP...EXT... with pushbutton/cover for indicators IP 54

Switching functions STP1/STP2 Without door monitoring contact

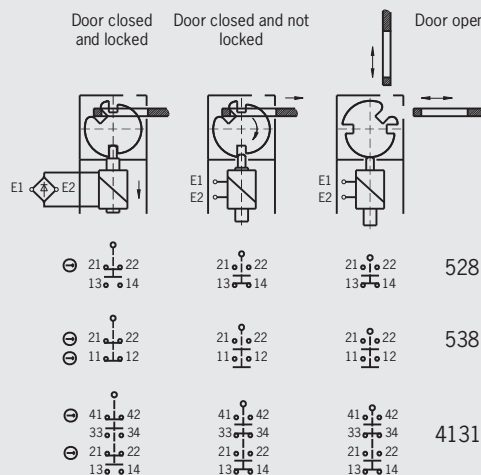

**Switching functions STP3/STP4
With door monitoring contact**

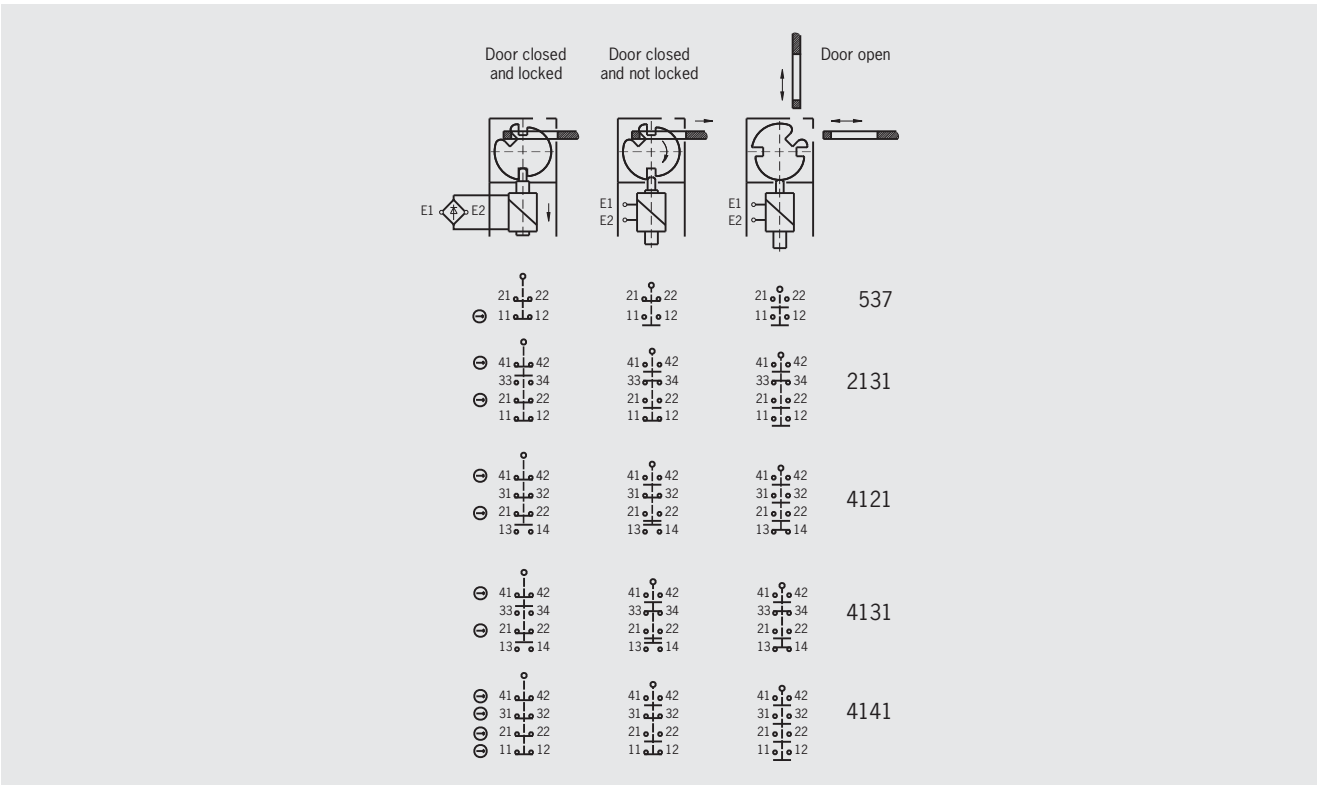

Switching functions STP-BI

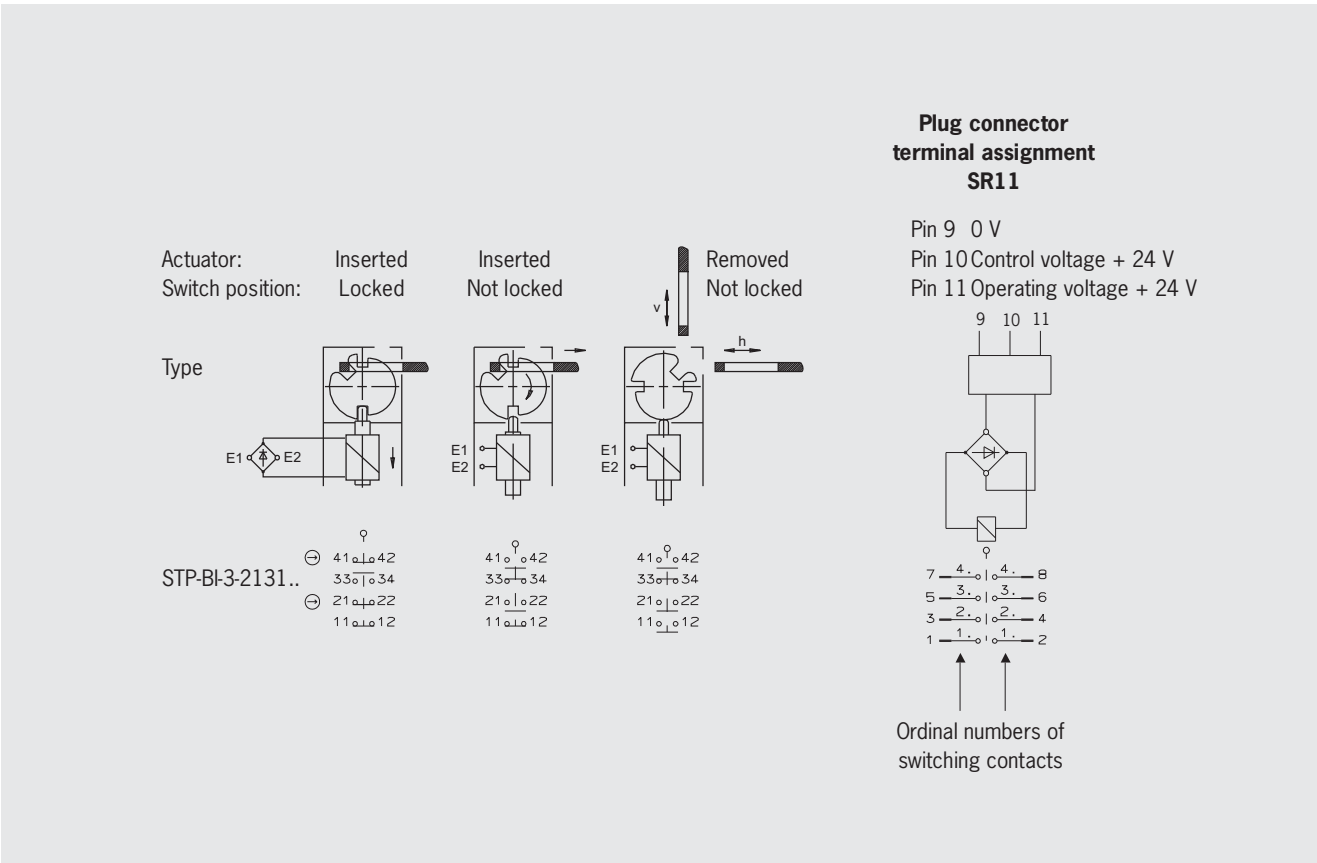

Safety switch STP-TW with guard locking and guard locking monitoring



The technical data on switches, switching elements and guard locking apply to all connections. Further technical data are given for the connection selected.

Reliability values acc. to EN ISO 13849-1

Parameter	Value	Unit
B10d	5 x 10 ⁶ operating cycles	

Switch		Value		Unit
Material	Housing	Reinforced thermoplastic		
	Actuating head	Die-cast aluminum		
	Cam in actuating head	Stainless steel		
Mechanical life	1 x 10 ⁶ operating cycles			
Ambient temperature	- 20 ... + 55		°C	
Weight	Approx. 0.62		kg	
Approach speed, max.	20		m/min	
Actuating force	35		N	
Extraction force (not locked)	30		N	
Retention force	20		N	
Locking force, max.	Approach direction			
	Top (v)	Side (h)	N	
Locking force F _{zh} in accordance with test principles GSET-19	Approach direction			
	From top (v)	Side (h)	N	
	Straight actuator	2,000	2,000	
Insertion depth (minimum required travel + permissible overtravel)	Actuator S standard			
Lateral approach direction (h)	24.5 + 5		mm	
Approach direction from above (v)	24.5 + 5		mm	

Switching element		Value		Unit
Switching principle	Slow-action switching contact			
Switching elements with 4 switching contacts	2131 2 NC ⊕ + 1 NO + 1 NC			
Min. switching current at 24 V DC	1		mA	
Switching voltage, min., at 10 mA	12		V	
Contact material	Silver alloy, gold flashed			

Guard locking		Value		Unit
Solenoid operating voltage	AC/DC 24 V +10/-15%			
Connection	Reverse polarity protected, integrated bridge rectifier			
Duty cycle	100		%	
Power consumption	8		W	

Connection, cable entry M20 x 1.5		Value		Unit
Connection	Screw terminal			
Version	M20 x 1.5			
Connection cross-section	0.34 ... 1.5		mm ²	
Degree of protection acc. to IEC 60529	IP 67			
Rated insulation voltage U _i	250		V AC/DC	
Rated impulse withstand voltage U _{imp}	2.5		kV	
Conventional thermal current I _{th}	4		A	
Short circuit protection according to IEC 60269-1 (control circuit fuse)	4		A gG	
Utilization category acc. to IEC 60947-5-1	AC-15	I _e 4 A U _e 230 V		
	DC-13	I _e 4 A U _e 24 V		

Switching functions STP-TW

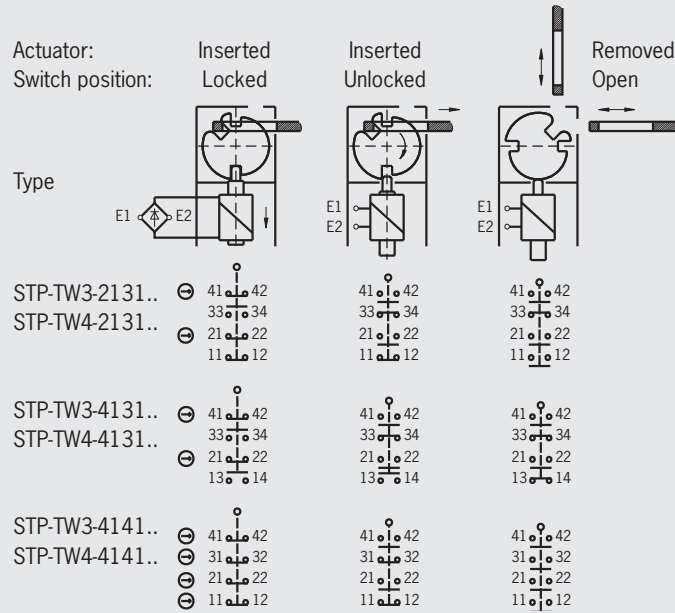

Safety switch STA... with guard locking and guard locking monitoring



The technical data on switches, switching elements and guard locking apply to all connections. Further technical data are given for the connection selected.

Reliability values acc. to EN ISO 13849-1

Parameter	Value	Unit
B10d	11.5 x 10 ⁶ operating cycles	

Switch



Parameter	Value	Unit	
material Housing	Die-cast alloy		
Mechanical life	1 x 10 ⁶ operating cycles		
Ambient temperature	- 20 ... + 80	°C	
Weight	Approx. 0.6	kg	
Approach speed, max.	20	m/min	
Actuating force	35	N	
Extraction force (not locked)	30	N	
Retention force	20	N	
Locking force, max.	Approach direction		
	From top (v)	Side (h)	
	3,000	3,000	
Locking force F _{zn} in accordance with test principles GSET-19	Approach direction		
	From top (v)	Side (h)	
Straight actuator	2,300	2,300	
Insertion depth (minimum required travel + permissible overtravel)	Actuator S standard	Actuator L for insertion funnel	
Lateral approach direction (h)	24.5 + 5	28.5 + 5	mm
Approach direction from above (v)	24.5 + 5	28.5 + 5	mm

Switching element



Parameter	Value	Unit
Switching principle	Slow-action switching contact	
Switching elements with 4 switching contacts	2131 2 NC ⊕ + 1 NO + 1 NC 4121 2 NC ⊖ + 1 NC + 1 NO 4131 2 NC ⊕ + 2 NO 4141 4 NC ⊕	
Min. switching current at 24 V DC	1	mA
Switching voltage, min., at 10 mA	12	V
Contact material	Silver alloy, gold flashed	

Guard locking



Parameter	Value	Unit
Solenoid operating voltage	AC/DC 24 V +10/-15%	
Connection	Reverse polarity protected, integrated bridge rectifier	
Duty cycle	100	%
Power consumption	8	W

Connection, cable entry M20 x 1.5



Parameter	Value	Unit
Connection	Screw terminal	
Version	M20 x 1.5	
Connection cross-section	0.34 ... 1.5	mm ²
Degree of protection acc. to IEC 60529	IP 67	
Rated insulation voltage U _i	250	V AC/DC
Rated impulse withstand voltage U _{imp}	2.5	kV
Conventional thermal current I _{th}	4	A
Short circuit protection according to IEC 60269-1 (control circuit fuse)	4	A gG
Utilization category acc. to IEC 60947-5-1	AC-15	I _e 4 A U _e 230 V
	DC-13	I _e 4 A U _e 24 V

Connection, plug connector SR11				
Parameter			Value	Unit
Connection			Plug connector	
Version			11-pin + PE	
Degree of protection acc. to IEC 60529			IP 65 ¹⁾	
Rated insulation voltage U_i			50	V AC/DC
Rated impulse withstand voltage U_{imp}			1.5	kV
Conventional thermal current I_{th}			4	A
Short circuit protection according to IEC 60269-1 (control circuit fuse)			4	A gG
Utilization category acc. to IEC 60947-5-1	AC-15		I_e 4 A U_e 50 V	
	DC-13		I_e 4 A U_e 24 V	

1) Screwed tight with the related plug connector (see page 104)

Connection, plug connector M23 (RC18)				
Parameter			Value	Unit
Connection			Plug connector	
Version			18-pin + PE	
Degree of protection acc. to IEC 60529			IP 65 ¹⁾	
Rated insulation voltage U_i			110	V AC/DC
Rated impulse withstand voltage U_{imp}			2.5	kV
Conventional thermal current I_{th}			4	A
Short circuit protection according to IEC 60269-1 (control circuit fuse)			4	A gG
Utilization category acc. to IEC 60947-5-1	AC-15		I_e 4 A U_e 110 V	
	DC-13		I_e 4 A U_e 24 V	

1) Screwed tight with the related plug connector (see page 105 - 106)

Switching functions STA1/STA2 Without door monitoring contact

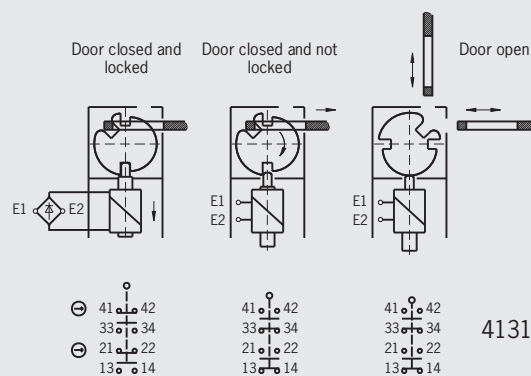

**Switching functions STA3/STA4
With door monitoring contact**

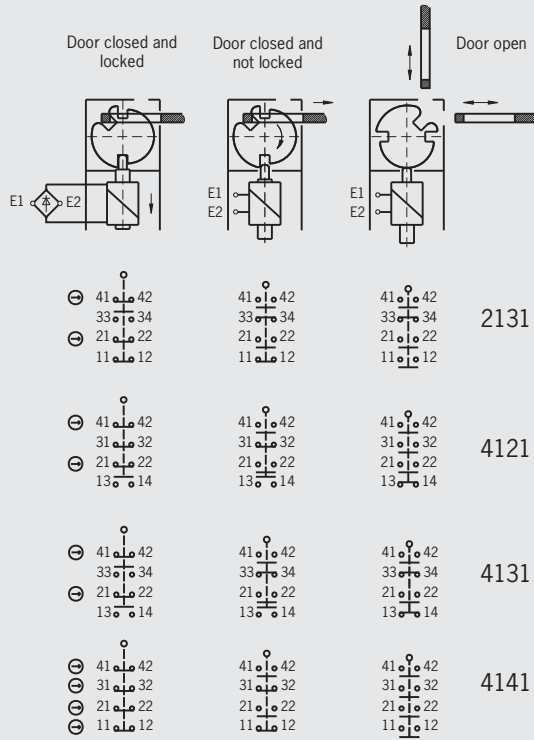

Safety switch STA-TW with guard locking and guard locking monitoring





The technical data on switches, switching elements and guard locking apply to all connections. Further technical data are given for the connection selected.

Reliability values acc. to EN ISO 13849-1

Parameter	Value	Unit
B _{10d}	4.5 x 10 ⁶ operating cycles	

Switch			Value	Unit
material	Housing		Die-cast alloy	
	Actuating head		Die-cast aluminum	
	Cam in actuating head		Stainless steel	
Mechanical life			1 x 10 ⁶ operating cycles	
Ambient temperature			- 20 ... + 55	°C
Weight			Approx. 0.62	kg
Approach speed, max.			20	m/min
Actuating force			35	N
Extraction force (not locked)			30	N
Retention force			20	N
Locking force, max.			Approach direction	
			Top (v) Side (h)	N
Locking force F _{zh} in accordance with test principles GSET-19			2,500 2,500	
			Approach direction	
Straight actuator			From top (v) Side (h)	N
			2,000 2,000	
Insertion depth (minimum required travel + permissible overtravel)			Actuator S standard	
Lateral approach direction (h)			24.5 + 5	mm
Approach direction from above (v)			24.5 + 5	mm

Switching element			Value	Unit
Switching principle			Slow-action switching contact	
Switching elements with 4 switching contacts			2131 4121	
			2 NC ⊕ + 1 NO + 1 NC 2 NC ⊕ + 1 NC + 1 NO	
Min. switching current at 24 V DC			1	mA
Switching voltage, min., at 10 mA			12	V
Contact material			Silver alloy, gold flashed	

Guard locking		 	Value	Unit
Solenoid operating voltage			AC/DC 24 V +10/-15%	
Connection			Reverse polarity protected, integrated bridge rectifier	
Duty cycle			100	%
Power consumption			8	W

Connection, cable entry M20 x 1.5			Value	Unit
Connection			Screw terminal	
Version			M20 x 1.5	
Connection cross-section			0.34 ... 1.5	mm ²
Degree of protection acc. to IEC 60529			IP 67	
Rated insulation voltage U _i			250	V AC/DC
Rated impulse withstand voltage U _{imp}			2.5	kV
Conventional thermal current I _{th}			4	A
Short circuit protection according to IEC 60269-1 (control circuit fuse)			4	A gG
Utilization category acc. to IEC 60947-5-1	AC-15		I _e 4 A U _e 230 V	
	DC-13		I _e 4 A U _e 24 V	

Switching functions STA-TW

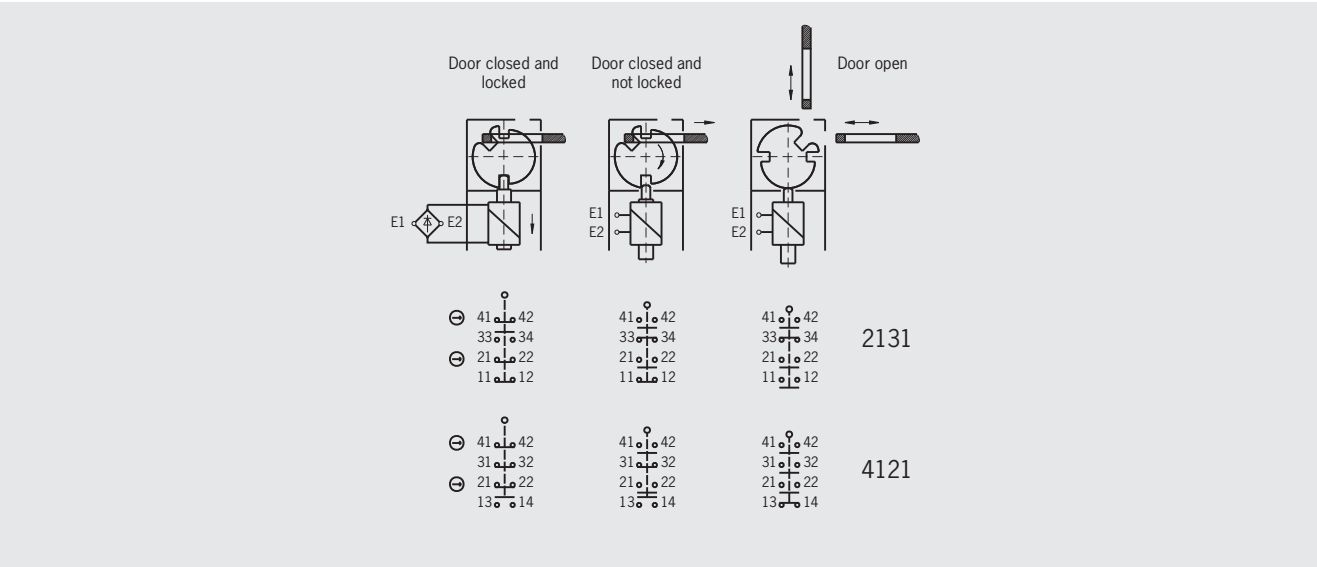

Safety switch STM with guard locking and guard locking monitoring

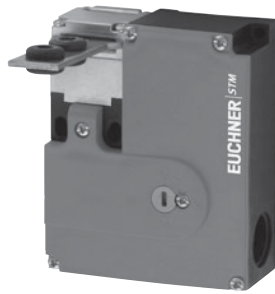



The technical data on switches, switching elements and guard locking apply to all connections. Further technical data are given for the connection selected.

Reliability values acc. to EN ISO 13849-1

Parameter	Value	Unit
B _{10d}	2 x 10 ⁶ operating cycles	

Switch 		
Parameter	Value	Unit
Housing material	Reinforced thermoplastic	
Mechanical life	2 x 10 ⁶ operating cycles	
Ambient temperature	- 20 ... + 55	°C
Weight	Approx. 0.4	kg
Approach speed, max.	20	m/min
Actuating force	35	N
Extraction force (not locked)	30	N
Retention force	20	N
Locking force, max.	Approach direction	
	From top (v)	Side (h)
	STM.A... (metal head)	2,000
	STM.N... (plastic head)	1,000
Locking force F _{2h} in accordance with test principles GSET-19	Approach direction	
	Top (v)	Side (h)
	STM.A... (metal head)	1,500
	STM.N... (plastic head)	700
Insertion depth (minimum required travel + permissible overtravel)	Actuator S standard	
Lateral approach direction (h)	24.5 + 5	mm
Approach direction from above (v)	24.5 + 5	mm

Switching element 		
Parameter	Value	Unit
Switching principle	Slow-action switching contact	
Switching elements	ÜK: 1 NC ⊖ SK: 222 2 NC ⊖	ÜK: 1 NC ⊖ SK: 242 1 NC ⊖ + 1 NO
Min. switching current at 24 V DC	1	mA
Switching voltage, min., at 10 mA	12	V
Contact material	Silver alloy, gold flashed	

Guard locking 		
Parameter	Value	Unit
Solenoid operating voltage	AC/DC 24 V +10/-15%	
Connection	Reverse polarity protected, integrated bridge rectifier	
Duty cycle	100	%
Power consumption	6	W

Connection, cable entry M20 x 1.5 		
Parameter	Value	Unit
Connection	Screw terminal	
Version	M20 x 1.5	
Connection cross-section	0.34 ... 1.5	mm ²
Degree of protection acc. to IEC 60529	IP 67	
Rated insulation voltage U _i	250	V AC/DC
Rated impulse withstand voltage U _{imp}	2.5	kV
Conventional thermal current I _{th}	4	A
Short circuit protection according to IEC 60269-1 (control circuit fuse)	4	A gG
Utilization category acc. to IEC 60947-5-1	AC-15	I _e 4 A U _e 230 V
	DC-13	I _e 4 A U _e 24 V

Switching functions STM

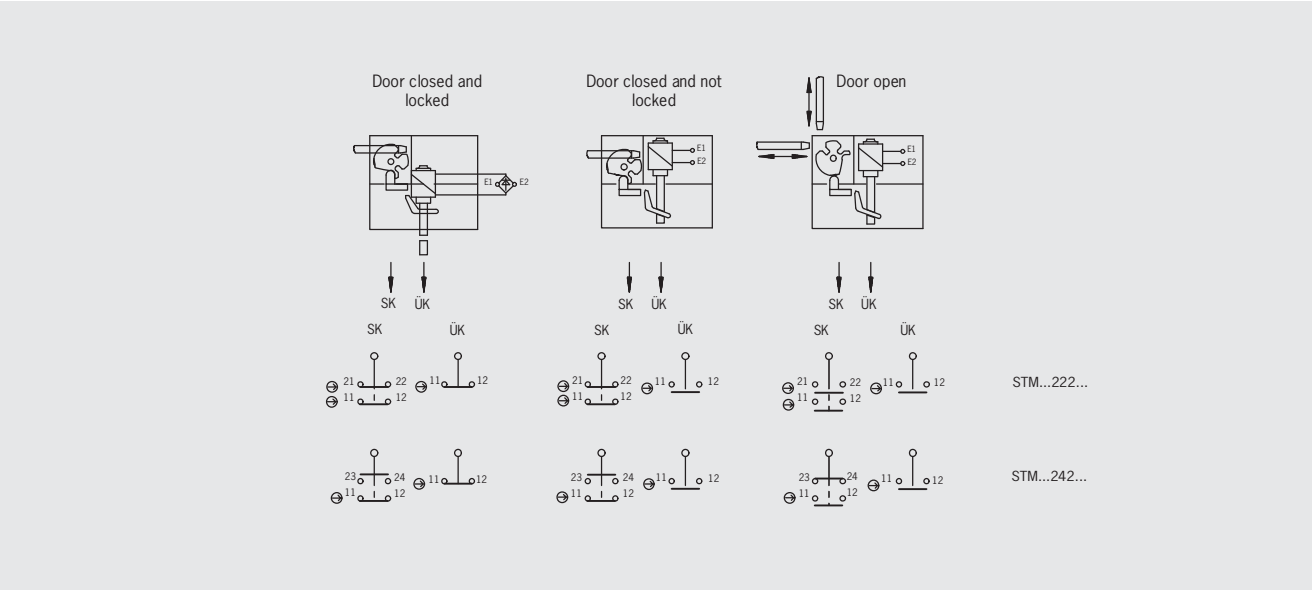

Safety switch TK... with guard locking (without failsafe locking mechanism)



The technical data on switches, switching elements and guard locking apply to all connections. Further technical data are given for the connection selected.

Reliability values acc. to EN ISO 13849-1

Parameter	Value	Unit
B10d	2 x 10 ⁶ operating cycles	

Switch



Parameter	Value	Unit
Material	Housing	Reinforced thermoplastic
	Actuating head	Metal
	Cam in actuating head	Metal
Mechanical life	1 x 10 ⁶ operating cycles	
Ambient temperature	-20 ... +55	°C
Weight	Approx. 0.6	kg
Retention force	5	N
Locking force (when fitted on switch head)	5,000	N

Switching element

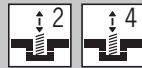

Parameter	Value	Unit
Switching principle	Slow-action switching contact	
Switching elements with 2 switching contacts	528 1 NC ⊕ + 1 NO	
Switching elements with 4 switching contacts	4131 2 NC ⊕ + 2 NO	
Min. switching current at 24 V DC	1	mA
Switching voltage, min., at 10 mA	12	V
Contact material	Silver alloy, gold flashed	

Guard locking



Parameter	Value	Unit
Solenoid operating voltage	AC/DC 24 V +10/-15%	
Connection	Reverse polarity protected, integrated bridge rectifier	
Duty cycle	100	%
Power consumption	8	W

Connection, cable entry M20 x 1.5



Parameter	Value	Unit
Connection	Screw terminal	
Version	M20 x 1.5	
Connection cross-section	0.34 ... 1.5	mm ²
Degree of protection acc. to IEC 60529	IP 67	
Rated insulation voltage U _i	250	V AC/DC
Rated impulse withstand voltage U _{imp}	2.5	kV
Conventional thermal current I _{th}	4	A
Short circuit protection according to IEC 60269-1 (control circuit fuse)	4	A gG
Utilization category acc. to IEC 60947-5-1	AC-15	I _e 4 A U _e 230 V
	DC-13	I _e 4 A U _e 24 V

Connection, plug connector SM8 (M12)



Parameter		Value	Unit
Connection		Plug connector	
Version		8-pin	
Degree of protection acc. to IEC 60529		IP 65 ¹⁾	
Rated insulation voltage U_i		30	V AC/DC
Rated impulse withstand voltage U_{imp}		1.5	kV
Conventional thermal current I_{th}		1	A
Short circuit protection according to IEC 60269-1 (control circuit fuse)		1	A gG
Utilization category acc. to IEC 60947-5-1	AC-15	I_e 1 A U_e 24 V	
	DC-13	I_e 4 A U_e 24 V	

1) Screwed tight with the related plug connector

Switching functions TK

locked

not locked

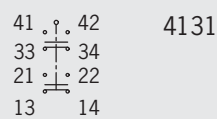
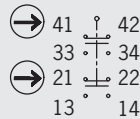
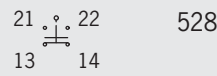
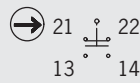
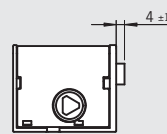
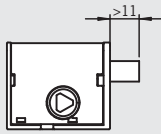

Accessories for Safety Switches

SR6			
Parameter		Value	Unit
Housing material		Plastic	
Number of pins		7 (6 + PE)	
Cable diameter		7 - 9	mm
Nominal voltage max.		250	V AC/DC
Degree of protection according to IEC 60529 (inserted)		IP 65	
Connection		Crimp contacts 0.5 to 1.5 mm ²	

SR11			
Parameter		Value	Unit
Housing material		Plastic	
Number of pins		12 (11 + PE)	
Cable diameter		8 - 10	mm
Nominal voltage max.		50	V AC/DC
Degree of protection according to IEC 60529 (inserted)		IP 65	
Connection		Crimp contacts 0.5 to 1.5 mm ²	

M12 with cable			
Parameter		Value	Unit
Housing material		Metal / plastic	
Number of pins		4	
Nominal voltage max.		30	V AC/DC
Degree of protection according to IEC 60529 (inserted)		IP 68	
Connection		4 open cable ends	

M12 with cable			
Parameter		Value	Unit
Housing material		Metal / plastic	
Number of pins		8	
Nominal voltage max.		30	V AC/DC
Degree of protection according to IEC 60529 (inserted)		IP 67	
Connection		8 open cable ends	

M23 (RC18)			
Parameter		Value	Unit
Housing material		Metal	
Number of pins		19 (18 + PE)	
Cable diameter		10 - 14	mm
Nominal voltage max.		32	V AC/DC
Degree of protection according to IEC 60529 (inserted)		IP 65	
Connection		19 crimp contacts 0.75 to 1.0 mm ²	

Built-in LED			
Parameter		Value	Unit
Material of housing		ABS/PC blend, black	
Material of cap		Transparent polycarbonate	
Degree of protection (installed)		IP 65	
Ambient temperature		-20 ... +50	°C
Connection		2 flexible wires	
Mounting		M20 x 1.5	
Operating voltage		24	V DC
Switch-on current		< 0.5	A
Current consumption		45	mA

Glossary

Actuating force

Switches *type 1:

The actuating force is the minimum force required to perform a switching operation.

Switches *type 2:

The actuating force is the force required to insert the *actuator in order to thus perform a switching operation.

Actuation (electrical / mechanical)

Transition of a moving contact from one switch position to another. This will result in a change to the switch state of an item of switchgear. A differentiation is made between electrical actuation (e.g. switching on – switching off) and mechanical actuation (e.g. closing – opening).

Actuator/actuating element

Switches type 1:

Mechanical element on a safety position switch that triggers the switching operation. Actuators are available in different designs, for example as roller plungers, chisel plunger or roller arms.

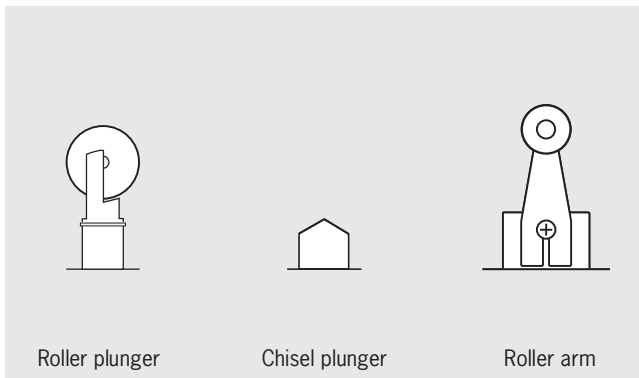

Approach speed

Speed at which a *position switch can be mechanically actuated. The permitted approach speed is dependent on the shape and material of the *actuating element and the approach angle. The higher the approach speed, the shallower the approach angle that should be chosen.

Automatic mode

The automatic mode is an *operating mode in which, unlike the *manual mode, only system starting is triggered by human intervention. All other actions are performed automatically.

Bolts

Bolts function as follows: The bolt tongue mechanically guides the *actuator when it is inserted into the *safety switch actuating head. The bolt mounted on the door frame comprises a protruding bolt tongue, the handle and the actuator, mounted offset somewhat to the rear. The switch bracket with the safety switch is fitted to the frame. The bolt absorbs forces that act on the switch and the *actuator and that could damage the switch and actuator.

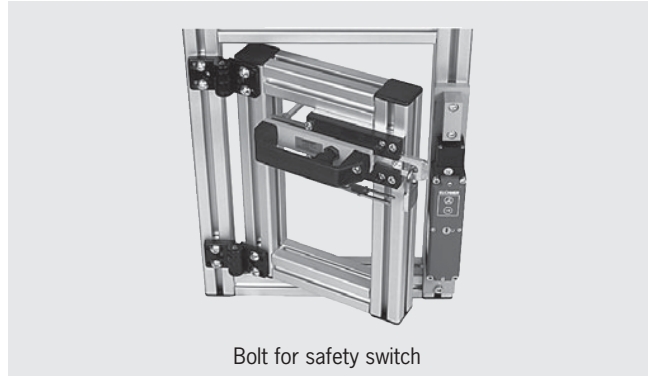

Bolt for safety switch

Category

The *categories according to EN ISO 13849-1 (B, 1, 2, 3 and 4) provide an assessment of the performance of safety-related parts of a control system on the occurrence of failures.

Closed-circuit current principle

On a *guard with *guard locking based on the closed-circuit current principle, the guard is locked by spring force until the guard locking solenoid is supplied with power. Unlocking is by solenoid force. The term *mechanical guard locking is also used.

Cyclic mode

An *operating mode in which each the working space on the machine is opened during every operating cycle and the operator therefore frequently needs to work in the *danger zone.

Danger zone

Any area in or around a machine in which a person is subject to a risk of injury or a health hazard.

The hazard can

- ▶ Either be present continuously on the correct use of the machine (movement of hazardous moving parts, arcs during welding, etc.)
- ▶ Or can occur unexpectedly (unintentional, unexpected starting, etc.).

Degree of protection

The degree of protection is defined according to EN 60529-1 and is given as an IP. "IP" is followed by two digits; the first digit gives the degree of protection against the penetration of solid foreign bodies and the second digit gives the degree of protection against the penetration of liquids. For *safety switches the degree of protection IP 55 is to be provided as a matter of preference (DGV Information 203-079).

Diversity

Diversity is the use of two different concepts to provide a function. For instance, the use of a switch *type 1* and a switch *type 2* on a *guard*. Here it is assumed that a single failure cannot affect two different concepts in the same way. Diversity also makes *tampering* more difficult and the safety of *redundant systems* is increased.

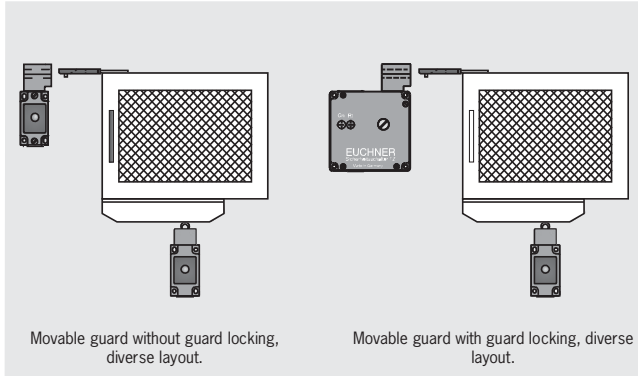

Electrical guard locking

Guard locking based on the *open-circuit current principle*.

Enable path

An enable path is used to generate a safety-related output signal. Enable paths act to the exterior like normally open contacts.

Enabling switches

If a *guard* is open, movements are only to be possible if the controls are operated continuously. These are controls with automatic return to their original position. In general the term enabling switches is used here.



Enabling switch with +/- buttons

Escape release

The escape release must make it possible to unlock the guard from within the *danger zone* without the use of tools. The device must be manually operated and must positively act on the *locking mechanism*. Actuation must result in permanent disabling of the *guard locking*.

Extraction force (also: positively driven opening force)

The extraction force is the required minimum force to achieve positively driven opening of the NC contacts.

Failsafe locking mechanism

The design feature of a *guard locking* device that ensures that the locking mechanism (solenoid plunger) cannot go into the locking position if the *guard* is open is also referred to in DGV Information 203-079 as failsafe locking mechanism.

The failsafe locking mechanism on an interlocking device with *guard locking* mechanically prevents the *safety switch* changing to the locked position with the *guard* open and therefore signaling a safe state.

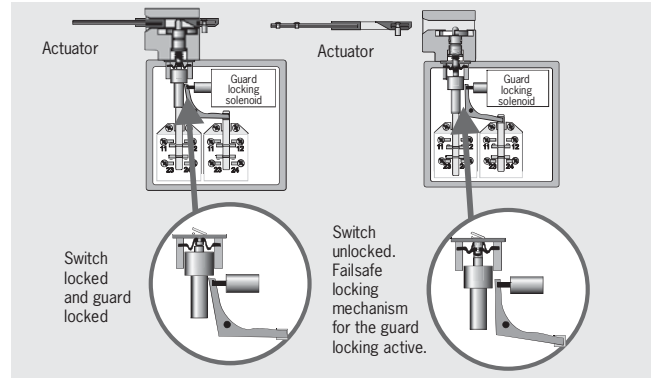

Guard

A *guard* is the part of the machine that is used as a barrier to protect against hazards. Guards form a physical barrier to the *danger zone*. They can be, e.g. safety doors, covers, fences, housings, etc.

Guard locking monitoring

The guard locking monitoring monitors the position of the guard locking solenoids. This device is positively linked to the switching element ÜK via a locking arm. On intentional or unintentional unlocking of the guard locking solenoid, the *positively driven contact* in this switching element is actuated and therefore signals the position of the guard locking solenoid. The sectional drawings show the safety switch STM in its three switch states:

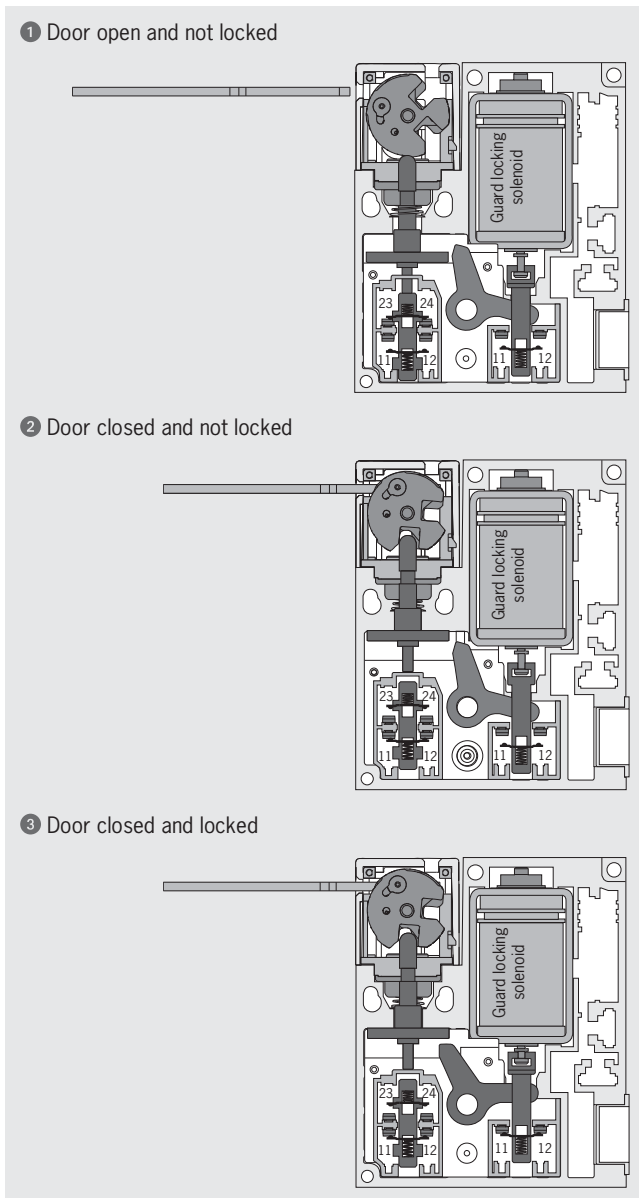

Hazardous states

Are states that could result in injury. *Safety switches* prevent this hazard on the correct use of the *guard* (cf. *Safe state*).

Hinged actuator

The hinged actuator, unlike the straight *actuator*, is spring mounted and as a result the actuator can be inserted in the actuating head without problems even with small door radii. With larger radii, a straight actuator can be used.

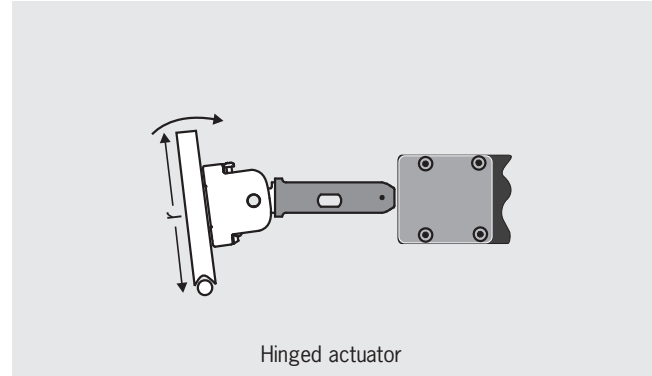

Interlocking, interlocking device

According to EN ISO 14119 an interlocking device is a mechanical, electrical or other device with the purpose of preventing operation of hazardous machine under certain conditions (usually as long as a *guard* is not closed).

Locking force

The locking force F_{zh} is the force that *guard locking* can withstand without damage.

The locking force in accordance with EN ISO 14119 includes an additional safety coefficient ($S = 1.3$) which is prescribed by the employers' liability insurance association in its test principles.

The locking force F_{zh} acc. to EN ISO 14119 can be calculated as follows:

$$F_{zh} = \frac{\text{Locking force, max.}}{\text{Safety coefficient}}$$

Manual mode

Manual mode is an *operating mode* in which the machine movements are not performed automatically, but using individual commands from the user.

Mechanical guard locking

Guard locking based on the *closed-circuit current principle*.

Mechanical release

The mechanical release makes it possible to access the machine if there is a malfunction, e. g. a power failure. Unlocking is performed using a tool or a key. The mechanical release should be protected against misuse (seal, lacquer).



Mounting safety switches and actuators

* *Safety switches* must be mounted such that they are adequately secured against changes to their position. Easy bypassing of the * *safety switch* must be prevented.

Open-circuit current principle

On a * *guard* with * *guard locking* based on the open-circuit current principle, the guard is locked until the power supply to the guard locking solenoid is interrupted. Unlocking is by spring force. The term * *electrical guard locking* is also used.

Operating modes

Every machine can have one or more operating modes that are defined by the type of machine and their application. If selection of operating mode can cause a hazardous situation, selection of this operating mode must be prevented by suitable means (e.g. key-operated switch, access code). Selection of operating mode on its own is not allowed to trigger machine operation. A separate action on the part of the operator must be required to start the operation of the machine. A means of indication of the selected operating mode is to be provided (e.g. the position of an operating mode selector switch, an indicator, a screen indication, etc.). Technical protective measures must remain effective for all operating modes. If it is necessary to disable technical protective measures (e.g. for setting up or maintenance work), a device for selection of operating mode is to be provided that can be secured in the required operating mode (e.g. locked with a key) so that automatic operation can be prevented. In addition, one or more of the following devices should be provided:

- ▶ Movement enable using an * *enabling switch*. The machine only runs as long as the enabling switch is operated.
- ▶ A portable control unit with a device for shutting down in an emergency or an enabling device. If a portable control unit is used, it must only be possible to trigger a movement from this point
- ▶ Movement speed or movement energy restriction
- ▶ Movement area restriction

PDF

The abbreviation PDF can have several meanings in safety engineering:

① Probability of Dangerous Failure

According to EN 61508, PDF is the probability of failure of a component and is used to determine the Safety Integrity Level (* *SIL*) for the overall machine.

② Proximity Devices with defined behavior under Fault conditions

Proximity switches with defined behavior under fault conditions (see EN 60947-5-3).

Position switches

Position switches are used to acquire the position of axes or moving * *guards*. As soon as a position switch is used as a safety-relevant component, the term position switch with safety function or safety-related position switch is used. In this case the switching element must contain at least one * *positively driven contact*.

Positive actuation

Positive actuation is the positive movement of a moving mechanical component together with another component – either by direct contact or via rigid parts. The second component is, as a result, moved positively by the first.

Positively driven opening force

* *Extraction force*

Redundancy

Redundancy is the use of more than one system to retain the same safety function at all times, even on the failure of individual components.

Even for the use of a * *position switch* with two positively driven NC contacts, the term redundant (dual-channel) system is often used. However, here it is to be noted that only duplication of the safety contacts is achieved, the mechanical drive (trip dog and plunger) remains single-channel as before. To set up a redundant system (from safety category 3 according to EN ISO 13849-1), both the mechanism (two * *position switches*) and the electronics should be of dual-channel layout. The safety of a redundant system is further increased by * *diversity*.

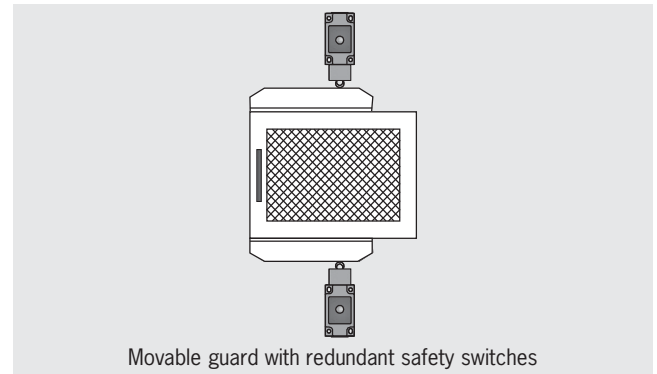

Retention force

The retention force is the maximum force that is allowed to be applied to the * *actuator* with the * *safety switch* in the locked state so that the guard locking cannot be unlocked.

In the case of switches without guard locking, the retention force is the maximum force that may be applied to the * *actuator* in the withdrawal direction while still guaranteeing reliable contact.

Risk

The combination of the probability of occurrence of harm and the severity of that harm in a hazardous situation.

Risk assessment

The * *standard* EN ISO 12100 contains procedures necessary to perform a risk assessment. The risk assessment initially involves a risk analysis and a subsequent risk evaluation. In EN ISO 13849-1 there is a simple procedure for determining the required * *category* to match the * *risk*.

Safe state

A safe state is provided if no hazard can be produced by an installation or machine on correct use (cf. * *Hazardous states*).

Safeguard

A safeguard is intended to protect personnel, products and the environment against hazards. A differentiation is made between * *guards* and protective devices.

Safety relay

Safety relays are used to evaluate switchgear connected (*safety switches, emergency stop switchgear, etc.). They ensure that the OSSD (Output Signal Switching Device) is opened.



Safety relay ESM

Safety Switch

A safety switch is part of a safety chain. It provides a safe signal in the input circuit. A stop signal is generated when the *guard is opened. In this way unintentional machine starting is prevented if the guard is open, that is *interlocking is achieved.

SIL (Safety Integrity Level)

According to EN 61508 the objective for the probability of failure on the execution of risk-reducing functions. The standard defines the requirements that are necessary to achieve a specific safety level (SIL).

Single-fault tolerance

Single-fault tolerance means that even after the occurrence of a single failure, the agreed safe function continues to be provided.

Standards

The European Machinery Directive states that if harmonized standards are observed, it can be assumed that the directive is met. Standards specify the requirements of the directive in more detail and as a rule represent the *general state-of-the-art*. Manufacturers of *safety switches must comply with EN 60947-5. All EUCHNER safety switches comply with this standard.

Start (automatic or manual)

An item of safety switchgear (e.g. *safety relay) can be started manually or automatically. On a manual start, an enable signal is generated after the Start button is pressed and a *safe state has been detected. This function is also termed static operation and is stipulated for emergency stop devices (EN 60204-1).

On an automatic start, an enable signal is generated after a safe state has been detected without any manual enable. This function is also termed dynamic operation and is not allowed for emergency stop devices.

Stop category

EN 60204-1 defines various stop categories; here stopping refers to the shutdown of the machine.

Stop category 0 means that the machine is shut down by the immediate shutdown of the power.

Stop category 1 means that the machine is shutdown in a controlled manner while the supply of power is maintained to bring the machine to a standstill. Once standstill has been reached, the power is interrupted.

Stop category 2 means that the machine is shutdown in a controlled manner while the supply of power is maintained to bring the machine to a standstill. The power is not interrupted at standstill. This stop category is not allowed to be used for shutdown in an emergency according to EN 60204.

Tampering

Tampering is the conscious disabling or bypassing of *guards and their components. *Safety switches and other safety devices must be designed such that the protective function cannot be changed or defeated by hand or using *one* simple action. Simple actions include using:

- ▶ Screwdrivers
- ▶ Ball-point pens
- ▶ Nails
- ▶ Pieces of wire
- ▶ Adhesive tape
- ▶ etc.

Actions that are not regarded as simple are actions that require more than one work step with tools.

The inability to *bypass by simple means* (DGUV Information 203-079) is:

- ▶ The removal or turning away of components of the locking surface with the aid of heavy tools (e.g. crowbar, angle grinder)
- ▶ The turning of the safety switch away from its protective position
- ▶ The use of a second *actuator
- ▶ The bridging of the contacts

It should be taken into account in the design that, despite *guards, straightforward and correct operation of machines and installations must be possible. If this aspect is not taken into account, the probability of defeating safety measures will increase.

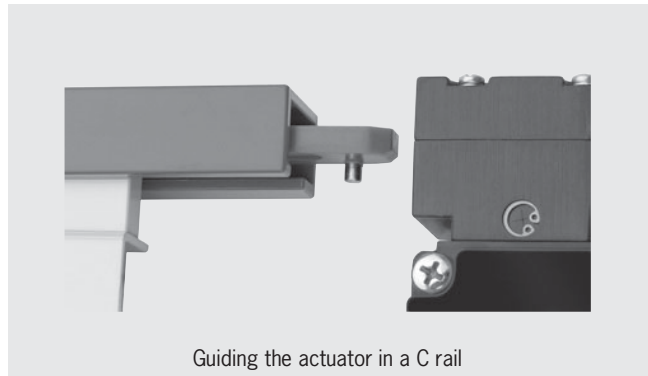

Guiding the actuator in a C rail

Testing

Testing is intended to ensure that a safety system functions correctly. Testing can be performed automatically, by the control system, in the form of monitoring or testing during the process. Depending on the requirements, a combination of automatic and manual testing is also possible. The testing must be repeated at defined intervals as a function of the risk analysis. Testing is required for *category 2 and 4 according to EN 954-1 and should also be performed for category 3.

Index by item designation

Item	Order no.	Page	Item	Order no.	Page
ACTUATOR S-G-SN-C2115	097861	96	C-M23F19-19XDIFPU01,5-MA-092907	092907	106
ACTUATOR S-GT-LN	095739	96	C-M23F19-19XDIFPU010,0-MA-092898	092898	106
ACTUATOR S-GT-SN	095738	96	C-M23F19-19XDIFPU010,0-MA-092901	092901	106
ACTUATOR S-W-SN-C2115	115073	97	C-M23F19-19XDIFPU010,0-MA-092902	092902	106
ACTUATOR S-WQ-LN	095741	96	C-M23F19-19XDIFPU03,0-MA-092816	092816	106
ACTUATOR S-WQ-SN	095740	96	C-M23F19-19XDIFPU03,0-MA-092908	092908	106
ACTUATOR S-WT-LN-C2115	105809	97	C-M23F19-19XDIFPU03,0-MA-092909	092909	106
ACTUATOR S-WT-SN-C2115	105808	97	C-M23F19-19XDIFPU06,0-MA-077014	077014	106
ACTUATOR-M-G	074076	90	C-M23F19-19XDIFPU06,0-MA-077018	077018	106
ACTUATOR-M-GQ	074079	90	C-M23F19-19XDIFPU06,0-MA-085194	085194	106
ACTUATOR-M-GS	074128	91	C-M23F19-19XDIFPU08,0-MA-077015	077015	106
ACTUATOR-M-GT	074078	90	C-M23F19-19XDIFPU08,0-MA-077019	077019	106
ACTUATOR-M-GTS	074130	91	C-M23F19-19XDIFPU08,0-MA-085195	085195	106
ACTUATOR-M-W	074077	90	C-M23F19-19XDIFPU15,0-MA-077016	077016	106
ACTUATOR-M-WS	074129	91	C-M23F19-19XDIFPU15,0-MA-077020	077020	106
ACTUATOR-M-WT	074080	90	C-M23F19-19XDIFPU15,0-MA-085196	085196	106
ACTUATOR-P-G	059226	92	C-M23F19-19XDIFPU20,0-MA-092726	092726	106
ACTUATOR-P-GN	074570	92	C-M23F19-19XDIFPU20,0-MA-092910	092910	106
ACTUATOR-P-GN	074576	93	C-M23F19-19XDIFPU20,0-MA-092911	092911	106
ACTUATOR-P-GT	070046	93	C-M23F19-19XDIFPU25,0-MA-092727	092727	106
ACTUATOR-P-W	059227	92	C-M23F19-19XDIFPU25,0-MA-092912	092912	106
ACTUATOR-P-WN	074571	92	C-M23F19-19XDIFPU25,0-MA-092913	092913	106
ACTUATOR-P-WNT	074577	93	C-M23F19-19XDIFPU30,0-MA-095993	095993	106
ACTUATOR-P-WT	070038	93	C-M23F19-19XDIFPU40,0-MA-102490	102490	106
Adapter NP-K	074578	100	C-M26F07-07X1,0PU05,0-MA-077632	077632	104
AE-B-A1-02,0-096230	096230	111	C-M26F07-07X1,0PU10,0-MA-077633	077633	104
AE-B-A1-02,0-F-097747	097747	111	C-M26F07-07X1,0PU15,0-MA-077634	077634	104
AE-B-A1-03,0-098313	098313	111	C-M26F07-07X1,0PU20,0-MA-098128	098128	104
AE-B-A1-03,0-F-111233	111233	111	C-M26F12-12X1,00PU05,0-MA-077629	077629	104
AE-B-A1-04,0-098314	098314	111	C-M26F12-12X1,00PU10,0-MA-077630	077630	104
AE-B-A1-06,0-125582	125582	111	C-M26F12-12X1,00PU15,0-MA-077631	077631	104
AE-B-A1-06,0-F-124770	124770	111	C-M26F12-12X1,0PU05,0-MA-077635	077635	104
AMP	126026	101	C-M26F12-12X1,0PU10,0-MA-077636	077636	104
AY-CAH-50,0-123032	123032	111	C-M26F12-12X1,0PU15,0-MA-077637	077637	104
AY-HDL-124204	124204	111	C-M26F12-12X1,0PU20,0-MA-096632	096632	104
Bolt 0 NP/TP	073535	113	C-M26F12-12X1,0PU25,0-MA-094749	094749	104
Bolt 1 NP/TP	073536	113	C-R22F07-07X1,0PU05,0-MA-077638	077638	104
Bolt BTC-ST/G-S-TH-00-X	106284	117	C-R22F07-07X1,0PU10,0-MA-077639	077639	104
Bolt BTC-ST/G-S-TH-01-F	106285	117	C-R22F07-07X1,0PU15,0-MA-077640	077640	104
Bolt BTC-T/GP-S-TH-00-X	106301	115	EKPM16/05	084572	108
Bolt BTC-T/GP-S-TH-01-F	106302	115	EKPM20/06	077679	108
Bolt NM	077233	112	EKPON12/06	077692	108
Bolt S-A	096384	116	EKVM12/04	086327	108
Bolt S-AF	096390	116	EKVM16/04	086328	108
Bolt S-C	096385	116	EKVM16/06	086330	108
Bolt S-CF	096391	116	EKVM20/06	077683	108
Bolt STP-GFK	098121	118	EKVM20/09	077684	108
Bolt TP-A	084430	114	EKVN12/06	077691	108
Bolt TP-AF	086186	114	Emergency unlocking STA	099876	110
Bolt TP-AF-NIRO	095222	114	Emergency unlocking TP/STP	099877	110
Bolt TP-C	084432	114	EMP-B1	093457	101
Bolt TP-CF	086188	114	EMP-B2	093458	101
Bolt TP-CF-NIRO	095221	114	EMP-SB	093456	101
Bolt TP-GFK	096616	118	EMP-SC	085753	102
Bolt TP-GFK-F	097602	118	Escape release handle	105329	110
C-M12F04-04X034PU05,0-GA	035613	103	GP1-2121A-M	090252	32
C-M12F04-04X034PU05,0-GA	035618	103	GP1-2131A-M	090255	32
C-M12F08-08X025PU05,0-MA	115112	103	GP1-3131A-M	090258	32
C-M12F08-08X025PU10,0-MA	115113	103	GP1-528A-M	089725	32
C-M12F08-08X025PU20,0-MA	115114	103	GP1-538A-M	090250	32
C-M12F08-08X025PU30,0-MA	115257	103	GP2-2131ASR11	096227	33
C-M23F19-19XDIFPU01,5-MA-092761	092761	106	Handle for wire front release	099795	111
C-M23F19-19XDIFPU01,5-MA-092906	092906	106	HINGED ACTUATOR P-LR	059440	94

Item	Order no.	Page
HINGED ACTUATOR P-LRN	074573	95
HINGED ACTUATOR P-OU	070050	94
HINGED ACTUATOR P-OUN	074572	95
HINGED ACTUATOR-S-LR-LN	096844	99
HINGED ACTUATOR-S-LR-SN	096838	98
HINGED ACTUATOR-S-OU-LN	096697	99
HINGED ACTUATOR-S-OU-SN	095315	98
Identical lock TP	121917	109
Identical lock TP C2293	109212	109
Insertion funnel M	083565	100
Insertion funnel NP/GP/TP	086237	100
Insertion funnel STP/STM	093157	100
Latch spring NP/TP	076501	109
LED M20x1.5	087423	108
LED set STP	098035	108
LED set TP	093752	108
LED-F M20x1.5	095510	108
Lock STA	105350	109
Lock TP	084177	109
Lock TP	086236	109
Lockout bar STP	105701	109
Lockout bar TP	096105	109
M4x14/V100	074063	111
M4x14/V100	086232	111
M5x10/V100	073455	111
M5x25/V100	073457	111
NM01AG-M	084553	19
NM01AK-M	084559	20
NM01AV-M	084545	18
NM01HBA-M	084527	17
NM01KBA-M	084522	16
NM01RBA-M	084515	15
NM01VZA-M	084451	22
NM01WOK-M	084495	14
NM02AG-MC2069	095360	19
NM02AG-SM4	084565	19
NM02AK-MC2069	095362	20
NM02AL-SM4	093246	18
NM02AV-MC2069	095366	18
NM02HBA-MC2069	095368	17
NM02KBA-MC2069	095370	16
NM02RBA-MC2069	095372	15
NM02VZA-M	084453	22
NM02VZA-MC2069	094470	22
NM02VZA-SM4	084564	23
NM02WOK-MC2069	095374	14
NM03AG-M	084557	19
NM03AK-M	084563	20
NM03AL-M	079121	18
NM03AV-M	084549	18
NM03HBA-M	084531	17
NM03KBA-M	084526	16
NM03RBA-M	084519	15
NM03VZA-M	084455	22
NM03WOK-M	084499	14
NM11AG-MC2069	095361	19
NM11AK-MC2069	095363	20
NM11AV-MC2069	095367	18
NM11HBA-MC2069	095369	17
NM11KBA-MC2069	095371	16
NM11RBA-MC2069	095373	15
NM11VZA-M	084452	22
NM11VZA-MC2069	094471	22

Item	Order no.	Page
NM11VZA-SM4	085626	23
NM11WOK-MC2069	095375	14
NM12AG-M	084556	19
NM12AK-M	084562	20
NM12AL-M	079120	18
NM12AV-M	084548	18
NM12HBA-M	084530	17
NM12KBA-M	084525	16
NM12RBA-M	084518	15
NM12VZA-M	084454	22
NM12WOK-M	084498	14
NP1-618AB-M	083680	28
NP1-618AS-M	083685	26
NP1-628AB-M	083686	28
NP1-628AS-M	083688	26
NP1-638AB-M	083690	28
NP1-638AS-M	083691	26
NP1-648AB-M	082276	28
NP1-648AS-M	082280	26
NP2-618AB	059446	29
NP2-618AS	059445	27
NP2-628AB	059448	29
NP2-628AS	059447	27
NP2-638AB	059450	29
NP2-638AS	059449	27
NP2-648AS	088924	27
NP3-628AS	098633	27
NP3-638AB	094509	29
NP3-638AS	084400	27
Pin crimp contact RCF	094309	105
Pin crimp contact RCF-C1825	094310	105
Pin crimp contact RCM-C1825	155811	105
PL3x26/V100	085576	111
PL3x30/V100	075532	111
PL3x30/V100	082237	111
PL3x38/V100	076755	111
RC18EF	074616	105
RC18EF-C1825	077025	105
RC18EM-C1815	129500	105
RC18WF	074617	105
RC18WF-C1825	077026	105
Release with automatic reset TP/STP	103110	110
Replacement key TP identical locking	099434	109
Replacement key TP unique locking	077206	109
SGA1A-2121A-M	103725	40
SGA1A-2131A-M	106307	40
SGA1A-2131A-M-EX	123460	40
SGA2A-2121ARC18-EXT5	104012	42
SGA2A-2121ASR11	116396	41
SGA2E-2131ASR11	106736	41
SGP-TW-1E-2131AC-M	100809	38
SGP-TW-1E-2131AC-M-S1	099900	38
SGP1E-2121A-M	097705	36
SGP1E-2131A-M	097706	36
SGP1E-3131A-M	097707	36
SGP2E-2131ASR11	099084	37
SGP2E-538ASR6	104022	37
SR11AM2-M20	091296	104
SR11EF	070859	104
SR11WF	054773	104
SR6AM2-M20	087180	104
SR6EF	013176	104
SR6K	013178	104

Item	Order no.	Page	Item	Order no.	Page
SR6WFG11R	024999	104	STP2A-4131A024L024M	091747	66
SRF	071260	104	STP2A-4131A024M	091492	66
SRM	071261	104	STP2A-528A024M	099855	66
STA-TW-3A-2131AC024M	105617	82	STP2A-538A024L024M	092490	66
STA-TW-3A-2131AC024M-S1	105888	82	STP2A-538A024M	092260	66
STA-TW-3A-4121AC024L024M	106379	82	STP3A-2131A024L024M	091748	62
STA-TW-3A-4121AC024M	106545	82	STP3A-2131A024L024RC18	099644	65
STA1A-4131A024M	096439	79	STP3A-2131A024M	091493	62
STA2A-4131A024M	096935	79	STP3A-2131A024MC1743	111064	67
STA2A-4131A024SR11	109574	80	STP3A-2131A024MC1993	102267	67
STA3A-2131A024L024RC18	099658	78	STP3A-2131A024SR11	099069	64
STA3A-2131A024L024RC18C1826	106623	78	STP3A-2131A024SR11C1993	103223	67
STA3A-2131A024M	096938	76	STP3A-2131A110M	099326	62
STA3A-2131A024MC1993	103660	81	STP3A-2131A230M	105972	62
STA3A-2131A024MF-EX	115584	77	STP3A-4121A024M	096890	62
STA3A-2131A230M	104171	76	STP3A-4121A024MC1993	096885	67
STA3A-4121A024L024M	106535	76	STP3A-4121A024SR11	096318	64
STA3A-4121A024M	096936	76	STP3A-4121A230M	094792	62
STA3A-4121A024MF-EX	115586	77	STP3A-4131A024M	091776	62
STA3A-4121A024SR11	105304	78	STP3A-4131A024SR11	103994	64
STA3A-4131A024M	099480	76	STP3A-4141A024L024M	112093	62
STA3A-4141A024L024M	100898	76	STP3A-4141A024M	099272	62
STA3A-4141A024L024RC18C1826	114416	78	STP3A-4141A024RC18C1993EXT4	109399	70
STA3A-4141A024M	099274	76	STP3A-4141A024RC18EXT1	104995	69
STA3A-4141A024RC18	100029	78	STP3D-4141A024L024M	099412	62
STA4A-2131A024L024M	103926	76	STP3D-4141A024M	097891	62
STA4A-2131A024L024RC18	105303	78	STP3D-537A024L024M	097210	62
STA4A-2131A024L024RC18C1826	106622	78	STP4A-2131A024L024M	091749	63
STA4A-2131A024M	096939	76	STP4A-2131A024M	091494	63
STA4A-2131A024MF-EX	115585	77	STP4A-2131A024SR11	097565	64
STA4A-4121A024M	096937	76	STP4A-2131A110M	097754	63
STA4A-4121A024MF-EX	123076	77	STP4A-4121A024L024M	100026	63
STA4A-4131A024M	099481	76	STP4A-4121A024M	093159	63
STA4A-4141A024M	109172	76	STP4A-4121A024MC1993	100322	67
STM1A-222B024-M	095396	84	STP4A-4121A024SR11	099301	64
STM1A-222B024-MC2160	098856	84	STP4A-4121A110M	094793	63
STM1A-222B230-M	098036	84	STP4A-4121A230M	094794	63
STM1A-242B024-M	095397	84	STP4A-4131A024M	093158	63
STM1N-222B024-M	091865	84	STP4A-4131A024SR11	111259	64
STM1N-222B230-M	098714	84	STP4A-4131A230M	104153	63
STM1N-242B024-M	092031	84	STP4A-4141A024M	099314	63
STM2A-222B024-M	095398	84	STP4A-4141A024MC1993	115749	67
STM2A-242B024-M	095399	84	STP4A-537A024M	092259	63
STM2N-222B024-M	092048	84	Switch bracket NM	077245	112
STM2N-242B024-M	092050	84	Switch bracket NP	073538	113
STP-BI-3A-2131A024SR11	100105	71	Switch bracket TP	073539	113
STP-TW-3A-2131AC024M	099973	72	Switch bracket TP-GFK	096613	118
STP-TW-3A-2131AC024M-S1	098827	72	TK1-4131AB024M	099686	86
STP-TW-3A-2131AC024SR11	106547	73	TK1-4131CB024M	099687	87
STP-TW-3A-4131AC024M	106153	72	TK1-528AB024M	094652	86
STP-TW-3A-4141AC024L024M	103048	72	TK1-528CB024M	094192	87
STP-TW-3A-4141AC024M	100746	72	TK1-528CB024SM8	122828	87
STP-TW-4A-2131AC024M	100849	73	TK1-528CB230M	100016	87
STP-TW-4A-2131AC024M-S1	100850	73	TK2-4131AB024M	099690	86
STP-TW-4A-2131AC024SR11	102565	73	TK2-4131CB024M	099691	87
STP-TW-4A-4131AC024M	103910	73	TP1-4131A024M	084115	44
STP-TW-4A-4141AC024L024M	103636	73	TP1-4131A024SR11	088202	45
STP1A-4131A024L024M	091746	66	TP1-4131A110M	084116	44
STP1A-4131A024M	091491	66	TP1-4131A230M	084117	44
STP1A-528A024M	092266	66	TP1-4131K024M	084150	46
STP1A-528A024RC18EXT1	106767	68	TP1-4131K024SR11	088217	47
STP1A-538A024M	092258	66	TP1-4131K110M	084254	46
STP1D-538A024L024M	092489	66	TP1-4131K230M	084255	46

Item	Order no.	Page
TP1-528A024L024M	094058	44
TP1-528A024M	084295	44
TP1-528A024SR6	087431	45
TP1-528A110M	084300	44
TP1-528A110SR6	087435	45
TP1-528A230M	084304	44
TP1-528A230SR6	087438	45
TP1-528K024M	084342	46
TP1-528K024SR6	088210	47
TP1-538A024L024M	093459	44
TP1-538A024M	084310	44
TP1-538A024SR6	087433	45
TP1-538A110M	084315	44
TP1-538A110SR6	087436	45
TP1-538A230M	084320	44
TP1-538A230SR6	087439	45
TP1-538K024M	084343	46
TP1-538K024SR6	088212	47
TP2-2121A024M	096528	44
TP2-4131A024M	084125	44
TP2-4131A024SR11	088203	45
TP2-4131A110M	084126	44
TP2-4131A230M	084128	44
TP2-4131K024M	084253	46
TP2-4131K024SR11	088218	47
TP2-528A024M	084325	44
TP2-528A024SR6	087441	45
TP2-528A110M	084330	44
TP2-528A110SR6	087444	45
TP2-528A230M	084332	44
TP2-528A230SR6	087448	45
TP2-528K024M	084344	46
TP2-528K024SR6	088214	47
TP2-538A024M	084333	44
TP2-538A024SR6	087442	45
TP2-538A110M	084334	44
TP2-538A110SR6	087446	45
TP2-538A230M	084335	44
TP2-538A230SR6	087449	45
TP2-538K024M	084346	46
TP2-538K024SR6	088215	47
TP3-2131A024L024M	093634	50
TP3-2131A024M	084142	48
TP3-2131A024MC1743	084285	57
TP3-2131A024MC1761	084290	48
TP3-2131A024MC1787	084289	50
TP3-2131A024MC1993	087400	57
TP3-2131A024RC18C1993EXT2	105546	59
TP3-2131A024SR11	088205	53
TP3-2131A024SR11C1993	097897	57
TP3-2131A110M	084143	48
TP3-2131A230M	084144	48
TP3-2131K024M	084264	54
TP3-2131K024SR11	088220	55
TP3-2131K230M	084265	54
TP3-4121A024BHA12EXT1A	105388	58
TP3-4121A024L024M	093636	50
TP3-4121A024M	084135	48
TP3-4121A024MC1743	087427	57
TP3-4121A024SR11	088206	53
TP3-4121A110M	084137	48
TP3-4121A230M	084138	48
TP3-4121K024M	084260	54

Item	Order no.	Page
TP3-4121K024SR11	088221	55
TP3-4121K110M	084261	54
TP3-4121K230M	084262	54
TP3-4131A024L024M	098403	50
TP3-4131A024M	084129	48
TP3-4131A024MC1993	106155	57
TP3-4131A024SR11	088204	53
TP3-4131A110M	084130	48
TP3-4131A230M	084131	48
TP3-4131K024M	084256	54
TP3-4131K024SR11	088219	55
TP3-4131K110M	084257	54
TP3-4131K230M	084258	54
TP3-4141A024L024M	137709	50
TP3-4141A024M	084270	48
TP3-4141A024MC1743	086165	57
TP3-4141A024RC18EXT1	103339	58
TP3-4141A024SM8C1992	087377	52
TP3-4141A024SR11	088922	53
TP3-4141A110M	088264	48
TP3-4141K024M	100684	54
TP3-537A024L024M	093460	50
TP3-537A024M	084336	48
TP3-537A024SR6	087434	52
TP3-537A110M	084337	48
TP3-537A110SR6	087437	52
TP3-537A230M	084338	48
TP3-537A230SR6	087440	52
TP3-537K024M	084347	54
TP3-537K024SR6	088213	55
TP4-2131A024L024M	093635	51
TP4-2131A024M	084145	49
TP4-2131A024MC1787	084159	51
TP4-2131A024SR11	088208	53
TP4-2131A110M	084147	49
TP4-2131A230M	084148	49
TP4-2131K024M	084266	54
TP4-2131K024SR11	088223	55
TP4-4121A024L024M	093637	51
TP4-4121A024M	084139	49
TP4-4121A024MC1787	084160	51
TP4-4121A024SR11	088209	53
TP4-4121A110M	084140	49
TP4-4121A230M	084141	49
TP4-4121K024M	084263	54
TP4-4121K024SR11	088224	55
TP4-4121K110M	084380	54
TP4-4131A024M	084132	49
TP4-4131A024SR11	088207	53
TP4-4131A110M	084133	49
TP4-4131A230M	084134	49
TP4-4131K024M	084259	54
TP4-4131K024SR11	088222	55
TP4-4141A024M	084275	49
TP4-4141A024SM8C1992	087378	52
TP4-4141A024SR11	088923	53
TP4-4141K024M	096296	54
TP4-4141K024SR11	088230	55
TP4-537A024M	084339	49
TP4-537A024SR6	087443	52
TP4-537A110M	084340	49
TP4-537A110SR6	087447	52
TP4-537A230M	084341	49

Index by order number

Order no.	Item	Page	Order no.	Item	Page
013176	SR6EF	104	077633	C-M26F07-07X1,0PU10,0-MA-077633	104
013178	SR6K	104	077634	C-M26F07-07X1,0PU15,0-MA-077634	104
024999	SR6WFPG11R	104	077635	C-M26F12-12X1,0PU05,0-MA-077635	104
035613	C M12F04 04X034PU05,0 GA	103	077636	C-M26F12-12X1,0PU10,0-MA-077636	104
035618	C M12F04 04X034PU05,0 GA	103	077637	C-M26F12-12X1,0PU15,0-MA-077637	104
054773	SR11WF	104	077638	C-R22F07-07X1,0PU05,0-MA-077638	104
059226	ACTUATOR -P-G	92	077639	C-R22F07-07X1,0PU10,0-MA-077639	104
059227	ACTUATOR-P-W	92	077640	C-R22F07-07X1,0PU15,0-MA-077640	104
059440	HINGED ACTUATOR-P-LR	94	077679	EKPM20/06	108
059445	NP2-618AS	27	077683	EKVM20/06	108
059446	NP2-618AB	29	077684	EKVM20/09	108
059447	NP2-628AS	27	077691	EKVN12/06	108
059448	NP2-628AB	29	077692	EKPON12/06	108
059449	NP2-638AS	27	079120	NM12AL-M	18
059450	NP2-638AB	29	079121	NM03AL-M	18
070038	ACTUATOR-P-WT	93	082237	PL3x30/V100	111
070046	ACTUATOR-GT	93	082276	NP1-648AB-M	28
070050	HINGED ACTUATOR-P-OU	94	082280	NP1-648AS-M	26
070859	SR11EF	104	083565	Insertion funnel M	100
071260	SRF	104	083680	NP1-618AB-M	28
071261	SRM	104	083685	NP1-618AS-M	26
073455	M5x10/V100	111	083686	NP1-628AB-M	28
073457	M5x25/V100	111	083688	NP1-628AS-M	26
073535	Bolt 0 NP/TP	113	083690	NP1-638AB-M	28
073536	Bolt 1 NP/TP	113	083691	NP1-638AS-M	26
073538	Switch bracket NP	113	084115	TP1-4131A024M	44
073539	Switch bracket TP	113	084116	TP1-4131A110M	44
074063	M4x14/V100	111	084117	TP1-4131A230M	44
074076	ACTUATOR-M-G	90	084125	TP2-4131A024M	44
074077	ACTUATOR-M-W	90	084126	TP2-4131A110M	44
074078	ACTUATOR-M-GT	90	084128	TP2-4131A230M	44
074079	ACTUATOR-M-GQ	90	084129	TP3-4131A024M	48
074080	ACTUATOR-M-WT	90	084130	TP3-4131A110M	48
074128	ACTUATOR-M-GS	91	084131	TP3-4131A230M	48
074129	ACTUATOR-M-WS	91	084132	TP4-4131A024M	49
074130	ACTUATOR-M-GTS	91	084133	TP4-4131A110M	49
074570	ACTUATOR-P-GN	92	084134	TP4-4131A230M	49
074571	ACTUATOR-P-WN	92	084135	TP3-4121A024M	48
074572	HINGED ACTUATOR-P-OUN	95	084137	TP3-4121A110M	48
074573	HINGED ACTUATOR-P-LRN	95	084138	TP3-4121A230M	48
074576	ACTUATOR-P-GN	93	084139	TP4-4121A024M	49
074577	ACTUATOR-P-WNT	93	084140	TP4-4121A110M	49
074578	Adapter NP-K	100	084141	TP4-4121A230M	49
074616	RC18EF	105	084142	TP3-2131A024M	48
074617	RC18WF	105	084143	TP3-2131A110M	48
075532	PL3x30/V100	111	084144	TP3-2131A230M	48
076501	Latch spring NP/TP	109	084145	TP4-2131A024M	49
076755	PL3x38/V100	111	084147	TP4-2131A110M	49
077014	C-M23F19-19XDIFPU06,0-MA-077014	106	084148	TP4-2131A230M	49
077015	C-M23F19-19XDIFPU08,0-MA-077015	106	084150	TP1-4131K024M	46
077016	C-M23F19-19XDIFPU15,0-MA-077016	106	084159	TP4-2131A024MC1787	51
077018	C-M23F19-19XDIFPU06,0-MA-077018	106	084160	TP4-4121A024MC1787	51
077019	C-M23F19-19XDIFPU08,0-MA-077019	106	084177	Lock TP	109
077020	C-M23F19-19XDIFPU15,0-MA-077020	106	084253	TP2-4131K024M	46
077025	RC18EF-C1825	105	084254	TP1-4131K110M	46
077026	RC18WF-C1825	105	084255	TP1-4131K230M	46
077206	Replacement key TP unique locking	109	084256	TP3-4131K024M	54
077233	Bolt NM	112	084257	TP3-4131K110M	54
077245	Switch bracket NM	112	084258	TP3-4131K230M	54
077629	C-M26F12-12X1,00PU05,0-MA-077629	104	084259	TP4-4131K024M	54
077630	C-M26F12-12X1,00PU10,0-MA-077630	104	084260	TP3-4121K024M	54
077631	C-M26F12-12X1,00PU15,0-MA-077631	104	084261	TP3-4121K110M	54
077632	C-M26F07-07X1,0PU05,0-MA-077632	104	084262	TP3-4121K230M	54

Order no.	Item	Page	Order no.	Item	Page
084263	TP4-4121K024M	54	084559	NM01AK-M	20
084264	TP3-2131K024M	54	084562	NM12AK-M	20
084265	TP3-2131K230M	54	084563	NM03AK-M	20
084266	TP4-2131K024M	54	084564	NM02VZA-SM4	23
084270	TP3-4141A024M	48	084565	NM02AG-SM4	19
084275	TP4-4141A024M	49	084572	EKPM16/05	108
084279	TP5-4120A024M	56	085194	C-M23F19-19XDIFPU06,0-MA-085194	106
084280	TP6-4120A024M	56	085195	C-M23F19-19XDIFPU08,0-MA-085195	106
084285	TP3-2131A024MC1743	57	085196	C-M23F19-19XDIFPU15,0-MA-085196	106
084289	TP3-2131A024MC1787	50	085576	PL3x26/V100	111
084290	TP3-2131A024MC1761	48	085626	NM11VZA-SM4	23
084295	TP1-528A024M	44	085753	EMP-SC	102
084300	TP1-528A110M	44	086165	TP3-4141A024MC1743	57
084304	TP1-528A230M	44	086186	Bolt TP-AF	114
084310	TP1-538A024M	44	086188	Bolt TP-CF	114
084315	TP1-538A110M	44	086232	M4x14/V100	111
084320	TP1-538A230M	44	086236	Lock TP	109
084325	TP2-528A024M	44	086237	Insertion funnel NP/GP/TP	100
084330	TP2-528A110M	44	086327	EKVM12/04	108
084332	TP2-528A230M	44	086328	EKVM16/04	108
084333	TP2-538A024M	44	086330	EKVM16/06	108
084334	TP2-538A110M	44	087180	SR6AM2-M20	104
084335	TP2-538A230M	44	087377	TP3-4141A024SM8C1992	52
084336	TP3-537A024M	48	087378	TP4-4141A024SM8C1992	52
084337	TP3-537A110M	48	087400	TP3-2131A024MC1993	57
084338	TP3-537A230M	48	087423	LED M20x1.5	108
084339	TP4-537A024M	49	087427	TP3-4121A024MC1743	57
084340	TP4-537A110M	49	087431	TP1-528A024SR6	45
084341	TP4-537A230M	49	087433	TP1-538A024SR6	45
084342	TP1-528K024M	46	087434	TP3-537A024SR6	52
084343	TP1-538K024M	46	087435	TP1-528A110SR6	45
084344	TP2-528K024M	46	087436	TP1-538A110SR6	45
084346	TP2-538K024M	46	087437	TP3-537A110SR6	52
084347	TP3-537K024M	54	087438	TP1-528A230SR6	45
084348	TP4-537K024M	54	087439	TP1-538A230SR6	45
084349	TP4-537K110M	54	087440	TP3-537A230SR6	52
084380	TP4-4121K110M	54	087441	TP2-528A024SR6	45
084400	NP3-638AS	27	087442	TP2-538A024SR6	45
084430	Bolt TP-A	114	087443	TP4-537A024SR6	52
084432	Bolt TP-C	114	087444	TP2-528A110SR6	45
084451	NM01VZA-M	22	087446	TP2-538A110SR6	45
084452	NM11VZA-M	22	087447	TP4-537A110SR6	52
084453	NM02VZA-M	22	087448	TP2-528A230SR6	45
084454	NM12VZA-M	22	087449	TP2-538A230SR6	45
084455	NM03VZA-M	22	087450	TP4-537A230SR6	52
084495	NM01WOK-M	14	088202	TP1-4131A024SR11	45
084498	NM12WOK-M	14	088203	TP2-4131A024SR11	45
084499	NM03WOK-M	14	088204	TP3-4131A024SR11	53
084515	NM01RBA-M	15	088205	TP3-2131A024SR11	53
084518	NM12RBA-M	15	088206	TP3-4121A024SR11	53
084519	NM03RBA-M	15	088207	TP4-4131A024SR11	53
084522	NM01KBA-M	16	088208	TP4-2131A024SR11	53
084525	NM12KBA-M	16	088209	TP4-4121A024SR11	53
084526	NM03KBA-M	16	088210	TP1-528K024SR6	47
084527	NM01HBA-M	17	088212	TP1-538K024SR6	47
084530	NM12HBA-M	17	088213	TP3-537K024SR6	55
084531	NM03HBA-M	17	088214	TP2-528K024SR6	47
084545	NM01AV-M	18	088215	TP2-538K024SR6	47
084548	NM12AV-M	18	088216	TP4-537K024SR6	55
084549	NM03AV-M	18	088217	TP1-4131K024SR11	47
084553	NM01AG-M	19	088218	TP2-4131K024SR11	47
084556	NM12AG-M	19	088219	TP3-4131K024SR11	55
084557	NM03AG-M	19	088220	TP3-2131K024SR11	55

Order no.	Item	Page
088221	TP3-4121K024SR11	55
088222	TP4-4131K024SR11	55
088223	TP4-2131K024SR11	55
088224	TP4-4121K024SR11	55
088230	TP4-4141K024SR11	55
088241	TP5-4120A230M	56
088264	TP3-4141A110M	48
088922	TP3-4141A024SR11	53
088923	TP4-4141A024SR11	53
088924	NP2-648AS	27
089725	GP1-528A-M	32
090250	GP1-538A-M	32
090252	GP1-2121A-M	32
090255	GP1-2131A-M	32
090258	GP1-3131A-M	32
091296	SR11AM2-M20	104
091491	STP1A-4131A024M	66
091492	STP2A-4131A024M	66
091493	STP3A-2131A024M	62
091494	STP4A-2131A024M	63
091746	STP1A-4131A024L024M	66
091747	STP2A-4131A024L024M	66
091748	STP3A-2131A024L024M	62
091749	STP4A-2131A024L024M	63
091776	STP3A-4131A024M	62
091865	STM1N-222B024-M	84
092031	STM1N-242B024-M	84
092048	STM2N-222B024-M	84
092050	STM2N-242B024-M	84
092258	STP1A-538A024M	66
092259	STP4A-537A024M	63
092260	STP2A-538A024M	66
092266	STP1A-528A024M	66
092489	STP1D-538A024L024M	66
092490	STP2A-538A024L024M	66
092726	C-M23F19-19XDIFPU20,0-MA-092726	106
092727	C-M23F19-19XDIFPU25,0-MA-092727	106
092761	C-M23F19-19XDIFPU01,5-MA-092761	106
092816	C-M23F19-19XDIFPU03,0-MA-092816	106
092898	C-M23F19-19XDIFPU010,0-MA-092898	106
092901	C-M23F19-19XDIFPU010,0-MA-092901	106
092902	C-M23F19-19XDIFPU010,0-MA-092902	106
092906	C-M23F19-19XDIFPU01,5-MA-092906	106
092907	C-M23F19-19XDIFPU01,5-MA-092907	106
092908	C-M23F19-19XDIFPU03,0-MA-092908	106
092909	C-M23F19-19XDIFPU03,0-MA-092909	106
092910	C-M23F19-19XDIFPU20,0-MA-092910	106
092911	C-M23F19-19XDIFPU20,0-MA-092911	106
092912	C-M23F19-19XDIFPU25,0-MA-092912	106
092913	C-M23F19-19XDIFPU25,0-MA-092913	106
093157	Insertion funnel STP/STM	100
093158	STP4A-4131A024M	63
093159	STP4A-4121A024M	63
093246	NM02AL-SM4	18
093456	EMP-SB	101
093457	EMP-B1	101
093458	EMP-B2	101
093459	TP1-538A024L024M	44
093460	TP3-537A024L024M	50
093634	TP3-2131A024L024M	50
093635	TP4-2131A024L024M	51
093636	TP3-4121A024L024M	50
093637	TP4-4121A024L024M	51

Order no.	Item	Page
093752	LED set TP	108
094058	TP1-528A024L024M	44
094192	TK1-528CB024M	87
094309	Pin crimp contact RCF	105
094310	Pin crimp contact RCF-C1825	105
094470	NM02VZA-MC2069	22
094471	NM11VZA-MC2069	22
094509	NP3-638AB	29
094652	TK1-528AB024M	86
094749	C-M26F12-12X1,0PU25,0-MA-094749	104
094792	STP3A-4121A230M	62
094793	STP4A-4121A110M	63
094794	STP4A-4121A230M	63
094895	TP5-4120A024SR11	56
094902	TP5-4120A024L024SR11	56
095221	Bolt TP-CF-NIRO	114
095222	Bolt TP-AF-NIRO	114
095315	HINGED ACTUATOR-S-OU-SN	98
095360	NM02AG-MC2069	19
095361	NM11AG-MC2069	19
095362	NM02AK-MC2069	20
095363	NM11AK-MC2069	20
095366	NM02AV-MC2069	18
095367	NM11AV-MC2069	18
095368	NM02HBA-MC2069	17
095369	NM11HBA-MC2069	17
095370	NM02KBA-MC2069	16
095371	NM11KBA-MC2069	16
095372	NM02RBA-MC2069	15
095373	NM11RBA-MC2069	15
095374	NM02WOK-MC2069	14
095375	NM11WOK-MC2069	14
095396	STM1A-222B024-M	84
095397	STM1A-242B024-M	84
095398	STM2A-222B024-M	84
095399	STM2A-242B024-M	84
095510	LED-F M20x1.5	108
095738	ACTUATOR S-GT-SN	96
095739	ACTUATOR S-GT-LN	96
095740	ACTUATOR S-WQ-SN	96
095741	ACTUATOR S-WQ-LN	96
095993	C-M23F19-19XDIFPU30,0-MA-095993	106
096105	Lockout bar TP	109
096204	TP6-4120A024SR11	56
096227	GP2-2131ASR11	33
096230	AE-BA1-02,0-096230	111
096296	TP4-4141K024M	54
096318	STP3A-4121A024SR11	64
096384	Bolt S-A	116
096385	Bolt S-C	116
096390	Bolt S-AF	116
096391	Bolt S-CF	116
096439	STA1A-4131A024M	79
096528	TP2-2121A024M	44
096613	Switch bracket TP-GFK	118
096616	Bolt TP-GFK	118
096632	C-M26F12-12X1,0PU20,0-MA-096632	104
096697	HINGED ACTUATOR-S-OU-LN	99
096838	HINGED ACTUATOR-S-LR-SN	98
096844	HINGED ACTUATOR-S-LR-LN	99
096885	STP3A-4121A024MC1993	67
096890	STP3A-4121A024M	62
096935	STA2A-4131A024M	79

Order no.	Item	Page	Order no.	Item	Page
096936	STA3A-4121A024M	76	100942		107
096937	STA4A-4121A024M	76	100945		107
096938	STA3A-2131A024M	76	100946		107
096939	STA4A-2131A024M	76	100947		107
097210	STP3D-537A024L024M	62	100948		107
097565	STP4A-2131A024SR11	64	100949		107
097602	Bolt TP-GFK-F	118	100950		107
097705	SGP1E-2121A-M	36	100951		107
097706	SGP1E-2131A-M	36	100952		107
097707	SGP1E-3131A-M	36	100953		107
097747	AE-B-A1-02,0-F-097747	111	100956		107
097754	STP4A-2131A110M	63	100960		107
097861	ACTUATOR S-G-SN-C2115	96	100961		107
097891	STP3D-4141A024M	62	100962		107
097897	TP3-2131A024SR11C1993	57	100967		107
098035	LED set STP	108	102267	STP3A-2131A024MC1993	67
098036	STM1A-222B230-M	84	102490	C-M23F19-19XDIFPU40,0-MA-102490	106
098121	Bolt STP-GFK	118	102502		107
098128	C-M26F07-07X1,0PU20,0-MA-098128	104	102503		107
098313	AE-B-A1-03,0-098313	111	102504		107
098314	AE-B-A1-04,0-098314	111	102505		107
098403	TP3-4131A024L024M	50	102506		107
098633	NP3-628AS	27	102507		107
098714	STM1N-222B230-M	84	102508		107
098827	STP-TW-3A-2131AC024M-S1	72	102509		107
098856	STM1A-222B024-MC2160	84	102510		107
099069	STP3A-2131A024SR11	64	102511		107
099084	SGP2E-2131ASR11	37	102512		107
099272	STP3A-4141A024M	62	102513		107
099274	STA3A-4141A024M	76	102514		107
099301	STP4A-4121A024SR11	64	102515		107
099314	STP4A-4141A024M	63	102516		107
099326	STP3A-2131A110M	62	102517		107
099412	STP3D-4141A024L024M	62	102518		107
099434	Replacement key TP identical locking	109	102519		107
099480	STA3A-4131A024M	76	102520		107
099481	STA4A-4131A024M	76	102521		107
099644	STP3A-2131A024L024RC18	65	102522		107
099658	STA3A-2131A024L024RC18	78	102523		107
099686	TK1-4131AB024M	86	102524		107
099687	TK1-4131CB024M	87	102525		107
099690	TK2-4131AB024M	86	102526		107
099691	TK2-4131CB024M	87	102565	STP-TW-4A-2131AC024SR11	73
099795	Handle for wire front release	111	103048	STP-TW-3A-4141AC024L024M	72
099855	STP2A-528A024M	66	103057	Triangular key	110
099876	Emergency unlocking STA	110	103110	Release with automatic reset TP/STP	110
099877	Emergency unlocking TP/STP	110	103149		107
099900	SGP-TW-1E-2131AC-M-S1	38	103150		107
099973	STP-TW-3A-2131AC024M	72	103151		107
100016	TK1-528CB230M	87	103152		107
100026	STP4A-4121A024L024M	63	103153		107
100029	STA3A-4141A024RC18	78	103154		107
100105	STP-BI-3A-2131A024SR11	71	103156		107
100322	STP4A-4121A024MC1993	67	103157		107
100684	TP3-4141K024M	54	103158		107
100746	STP-TW-3A-4141AC024M	72	103159		107
100809	SGP-TW-1E-2131AC-M	38	103160		107
100849	STP-TW-4A-2131AC024M	73	103223	STP3A-2131A024SR11C1993	67
100850	STP-TW-4A-2131AC024M-S1	73	103339	TP3-4141A024RC18EXT1	58
100898	STA3A-4141A024L024M	76	103636	STP-TW-4A-4141AC024L024M	73
100938		107	103660	STA3A-2131A024MC1993	81
100940		107	103725	SGA1A-2121A-M	40
100941		107	103910	STP-TW-4A-4131AC024M	73

A series of 30 horizontal grey bars, evenly spaced, intended for writing notes. The bars span the width of the page, leaving a small margin on the left and right.

Representatives

International

Austria

EUCHNER GmbH
Aumühlweg 17-19/Halle 1C
2544 Leobersdorf
Tel. +43 720 010 200
Fax +43 720 010 200-20
info@euchner.at

Benelux

EUCHNER (BENELUX) BV
Visschersbuurt 23
3356 AE Papendrecht
Tel. +31 78 615-4766
Fax +31 78 615-4311
info@euchner.nl

Brazil

EUCHNER Com.Comp.
Eletronicos Ltda.
Av. Prof. Luiz Ignácio Anhaia Mello,
no. 4387
Vila Graciosa
São Paulo - SP - Brasil
CEP 03295-000
Tel. +55 11 29182200
Fax +55 11 23010613
euchner@euchner.com.br

Canada

EUCHNER Canada Inc.
2105 Fasen Drive
Oldcastle, ON NOR 1L0
Tel. +1 519 800-8397
Fax +1 519 737-0314
sales@euchner.ca

China

EUCHNER (Shanghai)
Trading Co., Ltd.
No. 15 building,
No. 68 Zhongchuang Road,
Songjiang
Shanghai, 201613, P.R.C
Tel. +86 21 5774-7090
Fax +86 21 5774-7599
info@euchner.com.cn

Czech Republic

EUCHNER electric s.r.o.
Trnkova 3069/117h
628 00 Brno
Tel. +420 533 443-150
Fax +420 533 443-153
info@euchner.cz

Denmark

Duelco A/S
Systemvej 8 - 10
9200 Aalborg SV
Tel. +45 7010 1007
Fax +45 7010 1008
info@duelco.dk

Estonia

Sähkölehto OÜ
Hobujaama 4
Tallinn 10151
Tel. +372 56 645 400
office@sahkolehto.fi

Finland

Sähkölehto Oy
Holkkitie 14
00880 Helsinki
Tel. +358 9 7746420
office@sahkolehto.fi

France

EUCHNER France S.A.R.L.
Parc d'Affaires des Bellevues
Allée Rosa Luxembourg
Bâtiment le Colorado
95610 ERAGNY sur OISE
Tel. +33 1 3909-9090
Fax +33 1 3909-9099
info@euchner.fr

Hungary

EUCHNER Magyarország Kft.
FSD Park 2.
2045 Törökbálint
Tel. +36 1 919 0855
Fax +36 1 919 0857
info@euchner.hu

India

EUCHNER (India) Pvt. Ltd.
401, Bremen Business Center,
City Survey No. 2562,
University Road
Aundh, Pune - 411007
Tel. +91 20 64016384
Fax +91 20 25885148
info@euchner.in

Israel

Ilan & Gavish Automation Service Ltd.
26 Shenkar St. Qiryat Arie 49513
P.O. Box 10118
Petach Tikva 49001
Tel. +972 3 9221824
Fax +972 3 9240761
mail@ilan-gavish.com

Italy

TRITECNICA SpA
Viale Lazio 26
20135 Milano
Tel. +39 02 541941
Fax +39 02 55010474
info@tritecnica.it

Japan

EUCHNER Co., Ltd.
1662-3 Komakiharashinden
Komaki-shi, Aichi-ken
485-0012, Japan
Tel. +81 568 42 0157
Fax +81 568 42 0159
info@euchner.jp

Korea

EUCHNER Korea Co., Ltd.
115 Gasan Digital 2 - Ro
(Gasan-dong, Daeryung
Technotown 3rd Rm 810)
153 - 803 Kumchon-Gu, Seoul
Tel. +82 2 2107-3500
Fax +82 2 2107-3999
info@euchner.co.kr

Mexico

EUCHNER México S de RL de CV
Conjunto Industrial PK Co.
Carretera Estatal 431 km. 1+300
Ejido El Colorado, El Marqués
76246 Querétaro, México
Tel. +52 442 402 1485
Fax +52 442 402 1486
info@euchner.mx

Poland

EUCHNER Sp. z o.o.
Kraśnińskiego 29
40-019 Katowice
Tel. +48 32 252 20 09
Fax +48 32 252 20 13
info@euchner.pl

Portugal

PAM Servicos Tecnicos Industriais Lda.
Rua de Timor - Pavilhao 2A
Zona Industrial da Abelheira
4785-123 Trofa
Tel. +351 252 418431
Fax +351 252 494739
pam@mail.telepac.pt

Republic of South Africa

RUBICON
ELECTRICAL DISTRIBUTORS
4 Reith Street, Sidwell
6061 Port Elizabeth
Tel. +27 41 451-4359
Fax +27 41 451-1296
sales@rubiconelectrical.com

Romania

First Electric SRL
Str. Ritmului Nr. 1 Bis
Ap. 2, Sector 2
021675 Bucuresti
Tel. +40 21 2526218
Fax +40 21 3113193
office@firstelectric.ro

Singapore

BM Safety Singapore Pte Ltd.
Blk 3, Ang Mo Kio Industrial Park 2A
#05-06
Singapore 568050
Tel. +65 6744 8018
Fax +65 6744 1929
sales@bmsafety.com.sg

Slovakia

EUCHNER electric s.r.o.
Trnkova 3069/117h
628 00 Brno
Tel. +420 533 443-150
Fax +420 533 443-153
info@euchner.cz

Slovenia

SMM proizvodni sistemi d.o.o.
Jaskova 18
2000 Maribor
Tel. +386 2 4502326
Fax +386 2 4625160
franc.kit@smm.si

Spain

EUCHNER, S.L.
Gurutzegi 12 - Local 1
Polígono Belartza
20018 San Sebastian
Tel. +34 943 316-760
Fax +34 943 316-405
info@euchner.es

Sweden

Censit AB
Box 331
33123 Värnamo
Tel. +46 370 691010
Fax +46 370 18888
info@censit.se

Switzerland

EUCHNER AG
Falknisstrasse 9a
7320 Sargans
Tel. +41 81 720-4590
Fax +41 81 720-4599
info@euchner.ch

Taiwan

Daybreak Int'l (Taiwan) Corp.
3F, No. 124, Chung-Cheng Road
Shihlin 11145, Taipei
Tel. +886 2 8866-1234
Fax +886 2 8866-1239
day111@ms23.hinet.net

Turkey

EUCHNER Endüstriyel Emniyet
Teknolojileri Ltd. Şti.
Hattat Bahattin Sok.
Ceylan Apt. No. 13/A
Göztepe Mah.
34730 Kadıköy / Istanbul
Tel. +90 216 359-5656
Fax +90 216 359-5660
info@euchner.com.tr

United Kingdom

EUCHNER (UK) Ltd.
Unit 2 Petre Drive,
Sheffield
South Yorkshire
S4 7PZ
Tel. +44 114 2560123
Fax +44 114 2425333
sales@euchner.co.uk

USA

EUCHNER USA Inc.
6723 Lyons Street
East Syracuse, NY 13057
Tel. +1 315 701-0315
Fax +1 315 701-0319
info@euchner-usa.com

EUCHNER USA Inc.

Detroit Office
130 Hampton Circle
Rochester Hills, MI 48307
Tel. +1 248 537-1092
Fax +1 248 537-1095
info@euchner-usa.com

Germany

Augsburg

EUCHNER GmbH + Co. KG
Ingenieur- und Vertriebsbüro
Julius-Spokojny-Weg 8
86153 Augsburg
Tel. +49 821 56786540
Fax +49 821 56786541
peter.klopper@euchner.de

Berlin

EUCHNER GmbH + Co. KG
Ingenieur- und Vertriebsbüro
Ulmenstraße 115a
12621 Berlin
Tel. +49 30 50508214
Fax +49 30 56582139
alexander.walz@euchner.de

Chemnitz

EUCHNER GmbH + Co. KG
Ingenieur- und Vertriebsbüro
Am Vogelherd 2
09627 Bobritzsch-Hilbersdorf
Tel. +49 37325 906000
Fax +49 37325 906004
jens.zehrtner@euchner.de

Düsseldorf

EUCHNER GmbH + Co. KG
Ingenieur- und Vertriebsbüro
Tippgarten 3
59427 Unna
Tel. +49 2308 9337284
Fax +49 2308 9337285
christian.schimke@euchner.de

Essen

Thomas Kreißl
fördern - steuern - regeln
Hackenbergweg 8a
45133 Essen
Tel. +49 201 84266-0
Fax +49 201 84266-66
info@kreissl-essen.de

Freiburg

EUCHNER GmbH + Co. KG
Ingenieur- und Vertriebsbüro
Steige 5
79206 Breisach
Tel. +49 7664 403833
Fax +49 7664 403834
peter.seifert@euchner.de

Lübeck

EUCHNER GmbH + Co. KG
Ingenieur- und Vertriebsbüro
Am Stadtrand 13
23556 Lübeck
Tel. +49 451 88048371
Fax +49 451 88184364
martin.pape@euchner.de

Nürnberg

EUCHNER GmbH + Co. KG
Ingenieur- und Vertriebsbüro
Steiner Straße 22a
90522 Oberasbach
Tel. +49 911 6693829
Fax +49 911 6696722
ralf.paulus@euchner.de

Stuttgart

EUCHNER GmbH + Co. KG
Ingenieur- und Vertriebsbüro
Kohlhammerstraße 16
70771 Leinfelden-Echterdingen
Tel. +49 711 7597-0
Fax +49 711 7597-303
oliver.laier@euchner.de
uwe.kupka@euchner.de

Wiesbaden

EUCHNER GmbH + Co. KG
Ingenieur- und Vertriebsbüro
Adolfsallee 3
65185 Wiesbaden
Tel. +49 611 98817644
Fax +49 611 98895071
giancarlo.pasquesi@euchner.de



EUCHNER

More than safety.



Support hotline

You have technical questions about our products or how they can be used?
For further questions please contact your local sales representative.



Comprehensive download area

You are looking for more information about our products?
You can simply and quickly download operating instructions, CAD or ePLAN data and accompanying software for our products at www.euchner.com.



Customer-specific solutions

You need a specific solution or have a special requirement?
Please contact us. We can manufacture your custom product even in small quantities.



EUCHNER near you

You are looking for a contact at your location? Along with the headquarters in Leinfelden-Echterdingen, the worldwide sales network includes 18 subsidiaries and numerous representatives in Germany and abroad – you will definitely also find us near you.

www.euchner.com

EUCHNER GmbH + Co. KG

Kohlhammerstraße 16
70771 Leinfelden-Echterdingen
Germany
Tel. +49 711 7597-0
Fax +49 711 753316
info@euchner.de
www.euchner.com

EUCHNER

More than safety.